

ELECTRICAL ENGINEERING

Time Allowed: **Three Hours**

Maximum Marks: **300**

INSTRUCTIONS

1. IMMEDIATELY AFTER THE COMMENCEMENT OF THE EXAMINATION, YOU SHOULD CHECK THAT THIS TEST BOOKLET DOES NOT HAVE ANY UNPRINTED OR TORN OR MISSING PAGES OR ITEMS ETC. IF SO, GET IT REPLACED BY A COMPLETE TEST BOOKLET.
 2. **Please note that it is the candidate's responsibility to encode and fill in the Roll Number and Test Booklet series Code A, B, C or D carefully and without any omission or discrepancy at the appropriate places in the OMR Answer Sheet. Any omission/discrepancy will render the Answer Sheet liable for rejection.**
 3. You have to enter your Roll Number on the Test. Booklet in the Box provided alongside. **DO NOT write anything else on the Test Booklet.**
 4. This Test Booklet contains **150** items (questions). Each item comprises four responses (answers). You will select the response which you want to mark on the Answer Sheet. In case, you feel that there is more than one correct response, mark the response which you consider the best. In any case, choose **ONLY ONE** response for each item.
 5. You have to mark all your response **ONLY** on the separate Answer Sheet provided. See directions in the Answer Sheet.
 6. All items carry equal marks.
 7. Before you proceed to mark in the Answer Sheet the response to various items in the Test Booklet, you have to fill in some particular in the Answer Sheet as per instructions sent to you with your Admission Certificate.
 8. After you have completed filling in all your responses on the Answer Sheet and the examination has concluded, you should hand over to the Invigilator only the Answer Sheet. You are permitted to take away with you the Test Booklet.
 9. Sheets for rough work are appointed in the Test Booklet at the end.
 10. **Penalty for wrong answer:**
THERE WILL BE PENALTY FOR WRONG ANSWERS MARKED BY A CANDIDATE.
 - (i) There are alternate for the answer to every question. For each question for which a wrong answer has been given by the candidate, one-third (0.33) of the marks assigned to that question will be deducted as penalty.
 - (ii) If a candidate gives more than one answer, it will be treated as a wrong answer even if one of the given answers happens to be correct and there will be same penalty as above to that question.
 - (iii) If a question is left blank, i.e., no answer is given by the candidate, there will be no penalty for that question.
-

1. A point charge of 10^{-9}C is placed at a point A in free space. What is the intensity of electrostatic field on the surface of a sphere of radius 5 cm at centre A?

(Take $\frac{1}{4\pi\epsilon_0} = 9 \times 10^9$ in SI units)

- (A) 1800 V/m
(B) 3600 V/m
(C) 5360 V/m
(D) 2820 V/m

Answer: (B)

2. A generator develops 250 V and has an internal resistance of 100 ohm. If the load resistance is 100 ohm, then what is the efficiency of the generator?

- (A) 80% (B) 50% (C) 60% (D) 70%

Answer: (B)

3. A coil resistance 30Ω and inductance 0.6 H is switched on to a 240 V supply. What are the rate of change of current at the instant of closing the switch at $t = 0$ and the magnitude of the final steady state current respectively?

- (A) 80 A/sec and 80 A
(B) 400 A/sec and 8 A
(C) 8 A/sec and 80 A
(D) 400 A/sec and 80 A

Answer: (B)

4. A current of 10 A flows in a circuit with a 30° angle of lag when the applied voltage is 100 V.

What are the values of resistance and reactance in the circuit respectively ?

- (A) 8.66Ω and 5Ω
(B) 5Ω and 8.66Ω
(C) 6.66Ω and 4Ω
(D) 4Ω and 6.66Ω

Answer: (A)

5. Consider the following statements regarding reciprocity theorem :

1. In any passive linear bilateral network, if the single voltage source V_x , in branch x produces the current response I_y in branch y, then the removal of the voltage source from branch x and its insertion in branch y will produce the current response I_y in branch x.
2. The interchange of an ideal voltage source and an ideal ammeter in any passive, linear, bilateral circuit will not change the ammeter reading.
3. The interchange of an ideal current source and an ideal voltmeter in any passive linear bilateral circuit will change the voltmeter reading.

Which of the above statements are correct?

- (A) 1 and 3 only
(B) 1 and 2 only
(C) 2 and 3 only
(D) 1, 2 and 3

Answer: (B)

6. What is the value of v_o in the given circuit ?

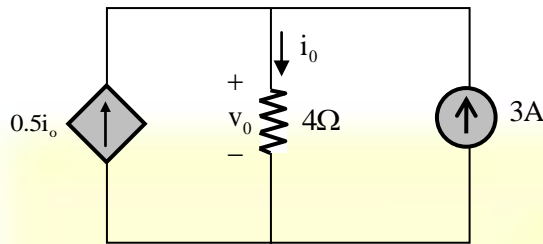

- (A) 12 V (B) 6 V (C) 24 V (D) 15 V

Answer: (C)

7. A network has 8 branches and 4 independent loops. How many nodes are there in the network?

- (A) 11 (B) 13 (C) 5 (D) 3

Answer: (C)

8. Three light bulbs are connected to a 9 V battery as shown in the figure.

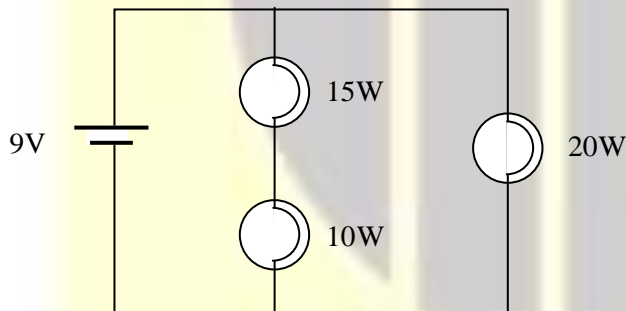

What are the values of the resistance of 20 W, 15 W, 10 W bulbs respectively ?

- (A) 4.05 Ω, 1.945 Ω, 1.297 Ω
(B) 6.02 Ω, 3.762 Ω, 3.162 Ω
(C) 7.672 Ω, 4.887 Ω, 4.223 Ω
(D) 8.345 Ω, 6.893Ω, 5.634 Ω

Answer: (A)

9. For the circuit in figure, the values of i_1 , and i_4 , are respectively,

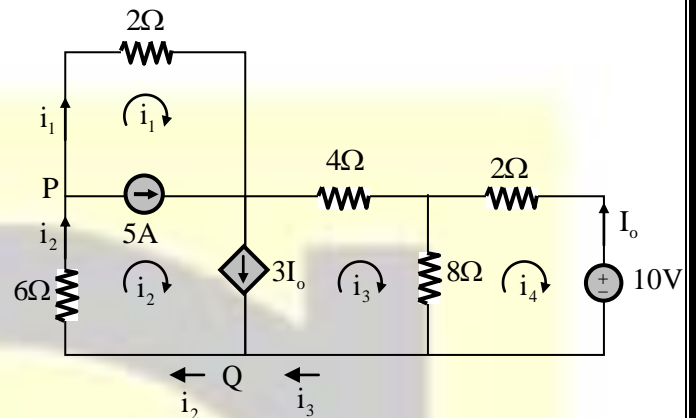

- (A) -7.5A, 2.143 A
(B) -2.5 A, 3.93 A
(C) 3.4 A, -6.5 A
(D) 7.1 A, -3.5 A

Answer: (B)

10. An energy source forces a constant current of 2A for 10 s to flow through a light bulb. If 2.3kJ is given off in the form of light and heat energy, what is the voltage drop across the bulb?

- (A) 120V (B) 115V (C) 110V (D) 105V

Answer: (B)

11. What is the input impedance of the circuit, if the circuit operates at $\omega = 50\text{rad/s}$?

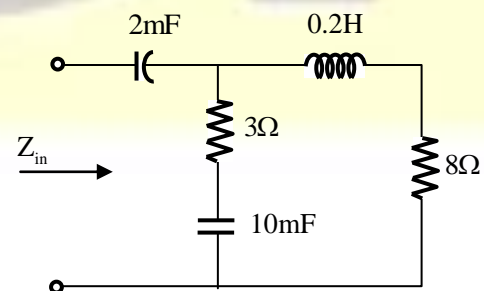

- (A) $(5.63 - j 8.94) \Omega$
- (B) $(3.22 - j11.07) \Omega$
- (C) $(4.54 + j 6.79) \Omega$
- (D) $(6.86 + j 13.54) \Omega$

Answer: (B)

12. A three-phase motor can be regarded as a balanced Y-load. A three-phase motor draws 5.6 kW, when the line voltage is 220 V and the line current is 18.2 A. What is the power factor of the motor ?
- (A) 0.8075
 - (B) 0.6134
 - (C) 0.9593
 - (D) 0.7947

Answer: (A)

13. A 0–150V voltmeter has a guaranteed accuracy of 1 % of full scale reading. The voltage measured by this instrument is 75 V. What is the percentage of limiting error?
- (A) 1% (B) 2% (C) 3% (D) 4%

Answer: (B)

14. What is the value of shunt resistance of an ammeter, if the range is extended from 1 mA to 10 mA and metre has a resistance of 27Ω ?
- (A) 3Ω (B) 4Ω (C) 2.5Ω (D) 3.5Ω

Answer: (A)

15. In a dynamometer type wattmeter at low power factor, the inductance of the pressure coil

introduces a serious error. This error can be minimized by

- (A) connecting a high resistance in series with it and connecting a capacitor across a part of this resistance.
- (B) connecting a high resistance in parallel with it and connecting a capacitor across a part of this resistance.
- (C) connecting a low resistance in series with it and connecting a capacitor across a part of this resistance.
- (D) connecting a low resistance in parallel with it and connecting a capacitor across a part of this resistance.

Answer: (A)

16. Which one of the following instruments is the most sensitive of the moving iron mechanism and has the most linear scale ?
- (A) Moving coil
 - (B) Hot wire
 - (C) Electrodynamic
 - (D) Radial vane repulsion

Answer: (A)

17. A voltmeter has a resistance of 300Ω and inductance of 0.12 H. This instrument reads correctly on DC. What is the reading on AC at 100 V when the frequency is 25 Hz ?
- (A) 99.80 V (B) 120.36 V
- (C) 142.00 V (D) 151.00 V

Answer: (A)

18. A voltmeter has a resistance of $20 \text{ k } \Omega$ and connected in series with an external resistance across a 230 V supply. If the instrument reads 160 V , then the value of external resistance is
- (A) 6745Ω
 (B) 7748Ω
 (C) 8750Ω
 (D) 9752Ω

Answer: (C)

19. A moving coil instrument gives full-scale deflection with 15 mA and has a resistance of 5Ω . The value of resistance to be connected in series to enable it to read up to 100 V is
- (A) 6666.66Ω
 (B) 6660.66Ω
 (C) 6661.60Ω
 (D) 6662.60Ω

Answer: (C)

20. The impedances of an AC bridge as shown in figure below are as follows:

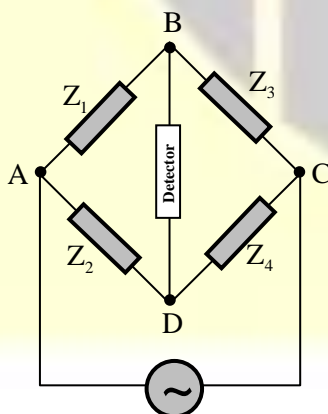

$Z_1 = 100 \Omega$ with phase angle of 60° , $Z_2 = 300 \Omega$ with phase angle of 0° , and $Z_3 = 50 \Omega$ with

- phase angle of 30° . What is the nature of unknown impedance Z_4 ?
- (A) Purely resistive circuit
 (B) Series R-C circuit
 (C) Series R-L circuit
 (D) Parallel R-L circuit

Answer: (B)

21. Consider a measuring system consisting of a sensor, an amplifier and an oscilloscope. The sensitivity of each equipment is as follows : Sensor sensitivity : 0.4 mV/C , Amplifier gain : 5.0 V/mV , and Oscilloscope sensitivity : 10 mV/V . What is the sensitivity of complete measurement system ?
- (A) 5.0 V/mV (B) 10 mV/V
 (C) $15.4 \text{ mV/}^\circ\text{C}$ (D) $20 \text{ mV/}^\circ\text{C}$

Answer: (D)

22. A moving coil meter of 50Ω resistance reads up to 25 mA . What is the value of series resistance, so that it can be read up to 10 V ?
- (A) 300Ω (B) 250Ω (C) 350Ω (D) 400Ω

Answer: (C)

23. Which one of the following analog to digital conversion methods is called potentiometric type analog to digital converter ?
- (A) Successive approximation method
 (B) Voltage to time conversion method
 (C) Voltage to frequency conversion method
 (D) Dual slope integration method

Answer: (A)

24. A piezoelectric transducer has a capacitance of 1500 pF and leakage resistance of $10^5 \text{ M } \Omega$. The oscilloscope used for read-out has a resistance

of 1 MQ in parallel with a capacitance of 500 pF. What is the time constant of the entire system ?

- (A) 0.002 s (B) 0.20 s (C) 20s (D) 200 s

Answer: (A)

25. Consider the following regarding the drawbacks of BCD arithmetic over binary arithmetic :

1. Perform arithmetic operations indirectly on decimal data.
2. Take more time for execution.
3. Less efficient use of memory.
4. Small number of computations are required.

Which of the above drawbacks are correct ?

- (A) 1 and 4 only
(B) 2 and 3 only
(C) 1, 2 and 3 only
(D) 1, 2, 3 and 4

Answer: (B)

26. Which one of the following registers holds the data on which the system has to operate, intermediate results and results of operations performed ?

- (A) Program control register
(B) Accumulator register
(C) Instruction register
(D) Input/output register

Answer: (B)

27. Which one of the following is *not* a general operation of machine cycle in a central processing unit ?

- (A) Fetch
(B) Decode
(C) Return
(D) Store

Answer: (C)

28. Consider the following statements in order to perform a write operation into a specified memory location, the MDR and MAR :

1. The word to be stored into the memory location is first loaded by the CPU into MDR.
2. The address of the location into which the word is to be stored is loaded by the CPU into MAR.
3. A write signal is issued by the CPU.

Which of the above statements are correct ?

- (A) 1 and 2 only
(B) 1 and 3 only
(C) 2 and 3 only
(D) 1, 2 and 3

Answer: (D)

29. In which one of the following modes does the DMA controller keep control of the bus until all the data has been transferred to (from) memory from (to) the peripheral device ?

- (A) Burst mode (B) Transfer mode
(C) Mice mode (D) Addressing mode

Answer: (A)

30. Which one of the following addressing modes leads to poor programming practice ?

- (A) Direct addressing mode
- (B) Indirect addressing mode
- (C) Immediate addressing mode
- (D) Implied addressing mode

Answer: (B)

31. Consider the following statements for a simple assembler :

1. It scans the entire assembly program twice, where each scan is called a pass.
2. It generates a table that includes all symbols and their binary values.
3. It will use the symbol table and other tables to generate the object program and output some information that will be needed by the linker.

Which of the above statements are correct ?

- (A) 1 and 2 only
- (B) 1 and 3 only
- (C) 2 and 3 only
- (D) 1, 2 and 3

Answer: (D)

32. Daisy-chaining method is used for

- (A) establishing priority
- (B) data transfer
- (C) initiating input and output
- (D) direct memory access

Answer: (A)

33. The performance of cache memory is measured in terms of

- (A) Read ratio
- (B) Reference ratio
- (C) Hit ratio
- (D) Locality ratio

Answer: (C)

34. According to the Belady's anomaly, the page-fault rate may

- (A) increase as the number of allocated frames increases.
- (B) increase as the number of allocated frames decreases.
- (C) not change as the number of allocated frames increases.
- (D) not change as the number of allocated frames decreases.

Answer: (A)

35. What is the maximum bit rate of a noiseless channel with a bandwidth of 1000 Hz transmitting a signal with two signal levels ?

- (A) 2000 bps
- (B) 3000 bps
- (C) 4000 bps
- (D) 6000 bps

Answer: (A)

36. A signal has eight data levels with a pulse duration of 1 ms. What is the bit rate?

- (A) 1000 bps
- (B) 2000 bps
- (C) 3000 bps
- (D) 4000 bps

Answer: (C)

37. In a CB configuration, the current amplification factor is 0.97. If the emitter current is 1 mA, the value of base current is

- (A) 0.97 mA
- (B) 1.0 mA
- (C) 0.03 mA
- (D) 1.03 mA

Answer: (C)

38. The power amplifiers in which the operating point is so adjusted that the collector current flows only during the positive half-cycle of the input signal are known as

- (A) Class-B amplifiers
- (B) Class-A amplifiers
- (C) Class-AB amplifiers
- (D) Class-C amplifiers

Answer: (A)

39. A multistage amplifier employs four stages, each of which has a voltage gain of 40. The overall gain of the amplifier is approximately

- (A) 32 dB
- (B) 64 dB
- (C) 96 dB
- (D) 128 dB

Answer: (D)

40. Consider the following statements regarding R-C coupled amplifiers :

1. The cost of R-C coupled amplifier is low because of low cost of coupling capacitors and resistors.

2. They occupy less space because of small size of resistors and capacitors.

3. They have better frequency response.

Which of the above statements are correct ?

- (A) 1 and 2 only
- (B) 2 and 3 only
- (C) 1,2 and 3
- (D) 1 and 3 only

Answer: (A)

41. For depletion type MOSFET : $I_D = 4.5$ mA at $V_{GS} = -2V$. What is the value of I_{DSS} if $V_P = -5$ V ?

- (A) 5.5 mA
- (B) 12.5 mA
- (C) 5.0 mA
- (D) 15mA

Answer: (B)

42. Which one of the following consists of a layer of metal at the top named gate, a silicon dioxide layer below it, and a semiconductor substrate as the bottom-most layer ?

- (A) JFET
- (B) BJT
- (C) MOSFET
- (D) DMOSFET

Answer: (C)

43. In a common base configuration, the alpha of the transistor is 0.99, its collector current is 1 mA and the collector to base current with emitter open is 1A. The value of base current is

(A) 29 A (B) 19 A (C) 9 A (D) 39 A

Answer: (C)

44. The MOSFET is in the cut-off state, when the gate source voltage is

- (A) less than gate to source voltage
- (B) greater than gate to source voltage
- (C) less than the threshold voltage
- (D) greater than the threshold voltage

Answer: (C)

45. For an ideal power supply, the output voltage is independent of the load and the percentage regulation is

- (A) equal to zero
- (B) equal to unity
- (C) greater than unity
- (D) less than unity but not zero

Answer: (A)

46. For an n-channel silicon FET with $a = 3 \times 10^{-4}$ cm and $N_D = 10^{15}$ electron/cm³, what is the pinch-off voltage if the dielectric constant of silicon is $\epsilon = 12\epsilon_0$ and $\epsilon_0 = \frac{1}{36\pi} \times 10^{-9}$?

- (A) 6.8 V
- (B) 5.2V
- (C) 8.8 V
- (D) 9.2 V

Answer: (A)

47. What is the output voltage for an integrator when input is a step voltage for $0 \leq t \leq 2$, $R_1 C_F = 3$ sec and $V_{in} = 6$ V

- (A) -4V
- (B) -6V
- (C) -8V
- (D) -10V

Answer: (A)

48. Consider the following statements related to Hall effect :

1. Hall effect is used to determine whether a semiconductor is n-type or p-type.
2. To find the carrier concentration.
3. Measuring the conductivity(σ), the mobility(μ) can be calculated.
4. The Hall effect has been incorporated into a magnetic field meter.

Which of the above statements are correct ?

- (A) 1 and 2 only
- (B) 2, 3, and 4 only
- (C) 1, 3 and 4 only
- (D) 1, 2, 3 and 4

Answer: (D)

49. The residue at the singular point $z = -2$ of

$$f(z) = \frac{1+z+z^2}{(z-1)^2(z+2)}$$

- (A) $\frac{1}{2}$
- (B) $\frac{1}{3}$
- (C) $\frac{4}{3}$
- (D) $\frac{3}{2}$

Answer: (B)

50. The solution of the differential equation

$$(1+e^{x/y}) + e^{x/y} \left(1 - \frac{x}{y}\right) \frac{dy}{dx} = 0$$

- (A) $x + ye^{x/y} = C$
- (B) $y + xe^{x/y} = C$
- (C) $1 + e^{x/y} = C$
- (D) $-\frac{x}{y^2} e^{x/y} = C$

Answer: (A)

51. If a force $\vec{F} = 2x^2y \hat{i} + 3xy \hat{j}$ displaces a particle in the xy-plane from (0, 0) to (1,4) along a curve $y = 4x^2$, what is the work done ?

- (A) $\frac{102}{5}$ (B) $\frac{5}{104}$ (C) $\frac{104}{5}$ (D) $\frac{5}{102}$

Answer: (C)

52. A die is tossed thrice. A success is getting 1 or 6 on a toss. Then, mean and variance of the number of successes are

- (A) Mean = $\frac{1}{2}$, Variance = $\frac{3}{2}$
 (B) Mean = 1, Variance = $\frac{3}{2}$
 (C) Mean = $\frac{1}{2}$, Variance = $\frac{2}{3}$
 (D) Mean = 1, Variance = $\frac{1}{2}$

Answer: (B)

53. In which matrix are eigenvectors corresponding to different eigen values orthogonal ?

- (A) Singular matrix
 (B) Non-singular matrix
 (C) Symmetric matrix
 (D) Non-symmetric matrix

Answer: (C)

54. '0' is a characteristic root of a matrix, if and only if, the matrix is

- (A) Idempotent matrix (B) Periodic matrix
 (C) Nilpotent matrix (D) Singular matrix

Answer: (D)

55. The value of $\int_0^{\pi/6} \cos^4 3\theta \sin^3 6\theta d\theta$ is

- (A) $\frac{1}{15}$ (B) $\frac{8}{3}$ (C) $\frac{7}{3}$ (D) $\frac{7}{15}$

Answer: (A)

56. The image of the line $I_m(z)=1$ under the mapping $w = z^2$ is

- (A) $u^2 = 4(v+1)$
 (B) $v^2 = 4(u+1)$
 (C) $u = 4(v+1)$
 (D) $v = 4(u+1)$

Answer: (B)

57. The number of emergency admissions each day to a hospital is found to have Poisson's distribution with mean 4. What is the probability that on a particular day there will be no emergency admissions ?

- (A) e^{-4} (B) e^{-2} (C) e^2 (D) e^4

Answer: (A)

58. How many seconds would a clock lose per day if the length of its pendulum was increased in the ratio of 900 : 901 ?

- (A) 48 (B) 25 (C) 16 (D) 56

Answer: (A)

59. In estimating the cost of a pile of bricks measured as $2m \times 15m \times 1.2 m$, the tape is stretched 1% beyond the standard length. If the

count is 450 bricks to 1 cu.m. and bricks cost 530 per 1000, what is the approximate error in the cost ?

- (A) Rs. 257.58
- (B) Rs. 152.65
- (C) Rs. 345.41
- (D) Rs. 329.49

Answer: (A)

60. Three cities A, B, C are equidistant from each other. One motorist travels from A to B at 20 km/hr., from B to C at 40 km/hr., from C to A at 50 km/hr. What is the average speed?

- (A) 38.3 km
- (B) 31.6 km
- (C) 39.2 km
- (D) 34.6km

Answer: (B)

61. What is the line energy of dislocations on BCC iron ? The Burgers' vector in iron is of the $1/2 < 111 >$ type. The shear modulus of iron is 80.2 GN/m². Given that the lattice parameters of BCC iron, $a = 2.87 \text{ \AA}$.

- (A) $1.40 \times 10^{-9} \text{ J/m}$
- (B) $3.12 \times 10^{-9} \text{ J/m}$
- (C) $2.476 \times 10^{-9} \text{ J/m}$
- (D) $6.544 \times 10^{-9} \text{ J/m}$

Answer: (C)

62. Nichrome is an alloy of

- (A) Manganese 2.5%, Nickel 81% to 84%, Chromium 14% to 17% and a little percentage of Iron.
- (B) Manganese 2.0%, Nickel 78% to 81%, Chromium 17% to 20% and a little percentage of Iron.
- (C) Manganese 1.5%, Nickel 75% to 78%, Chromium 20% to 23% and a little percentage of Iron.
- (D) Manganese 0.5%, Nickel 72% to 75%, Chromium 23% to 26% and a little percentage of Iron.

Answer: (C)

63. Which one of the following statements is not correct regarding bundle conductors ?

- (A) Voltage stress at the conductor surface is reduced by using bundle conductors.
- (B) Corona loss is smaller by using bundle conductors.
- (C) Current carrying capacity is decreased in bundle conductors as compared with a single conductor of equivalent cross-sectional area.
- (D) The line having bundle conductors is less liable to cause radio interference.

Answer: (C)

64. What is the loss of energy per hour in a ferromagnetic specimen when it is subjected to 50 Hz magnetisation, if the specimen weighs 50

kg, area of hysteresis loop is 200 joules per m and density of iron is 7500 kg/m^3 ?

- (A) $2.4 \times 10^5 \text{ J}$
- (B) $3.9 \times 10^4 \text{ J}$
- (C) $2.9 \times 10^4 \text{ J}$
- (D) $4.5 \times 10^5 \text{ J}$

Answer: (A)

65. A heater element is made of nichrome wire having resistivity equal to $100 \times 10^{-8} \Omega \text{ m}$. The diameter of the wire is 0.4 mm. The length of the wire required to get a resistance of 40Ω and 1000 W is

- (A) 5.0 metres
- (B) 4.5 metres
- (C) 5.5 metres
- (D) 4.0 metres

Answer: (A)

66. The lead material works as superconductor at a temperature of $T_C = 7.26 \text{ K}$. If the constant characteristics of the lead material at 0 K is $H_0 = 8 \times 10^5 \text{ A/m}$, then what is the magnetic field in the lead at 5K?

- (A) $\frac{8 \times 10^5}{\pi} \text{ A/m}$
- (B) $\frac{4 \times 10^5}{4\pi} \text{ A/m}$
- (C) $\frac{10^5}{2\pi} \text{ A/m}$
- (D) $4\pi \times 10^5 \text{ A/m}$

Answer: (*)

67. What is the approximate lattice constant "a" of a substance having FCC lattice, molecular weight 60.2 and density 6250 kg/m^3 ?

(Consider $N = 6.02 \times 10^{26} / \text{kg-mole}$)

- (A) $5 \times 10^{-10} \text{ m}$
- (B) $3 \times 10^{-10} \text{ m}$
- (C) $4 \times 10^{-10} \text{ m}$
- (D) $8 \times 10^{-10} \text{ m}$

Answer: (C)

68. Which one of the following statements is *not* correct regarding dielectric loss ?

- (A) The loss increases proportionately with the frequency of applied voltage.
- (B) Presence of humidity increases the loss.
- (C) Temperature rise normally decreases the loss.
- (D) Voltage increase causes increased dielectric loss.

Answer: (C)

69. In a ferromagnetic material, the losses due to hysteresis are

- (A) directly proportional to the supply frequency.
- (B) inversely proportional to the supply frequency.
- (C) inversely proportional to square of the supply frequency.
- (D) directly proportional to square of the supply frequency

Answer: (A)

70. Which one of the following statements is not correct regarding tungsten, which is used as filament material?

- (A) It has the highest melting point amongst all metals.
- (B) It can be drawn into very thin wires.
- (C) It has very high tensile strength in its thinnest form.
- (D) It becomes brittle at high temperature.

Answer: (D)

71. The spontaneous magnetization is the most important characteristic of

- (A) paramagnetic materials
- (B) ferromagnetic materials
- (C) diamagnetic materials
- (D) permalloy

Answer: (B)

72. What is the temperature coefficient of resistance of material used in a resistor if the resistance at 25°C is 50 Ω and at 70°C is 57.2 Ω ?

- (A) $\frac{1}{168.5}$
- (B) $\frac{1}{378.5}$
- (C) $\frac{1}{463.5}$
- (D) $\frac{1}{287.5}$

Answer: (D)

73. One of the primary purposes of using feedback in control systems is to

- (A) increase the sensitivity of the system to parameter variations.

(B) reduce the sensitivity of the system to parameter variations.

(C) increase the effect of distortion.

(D) reduce the bandwidth of the system.

Answer: (B)

74. Transfer function of the system is given by

$$G(s) = \frac{1000}{(1+0.1s)(1+0.001s)}$$

The corner frequency ω_1 and ω_2 for the system are respectively,

- (A) 2 rad/sec and 4 rad/sec
- (B) 8 rad/sec and 10 rad/sec
- (C) 100 rad/sec and 10 rad/sec
- (D) 10 rad/sec and 1000 rad/sec

Answer: (D)

75. Which one of the following statements is not correct with respect to cascade lead compensator ?

- (A) The undamped natural frequency ω_n is increased considerably which reduces the settling time.
- (B) It is used to improve the transient response of the given system.
- (C) It is used to improve the steady state performance of the given system.
- (D) The phase angle contribution to the root-loci is positive at the dominant pole position.

Answer: (C)

76. Which of the following is a powerful frequency domain method of extracting the information regarding stability as well as relative stability of a system without the need to evaluate roots of the characteristics equation ?
- (A) Routh criterion only
 (B) Root locus method only
 (C) Both Routh criterion and Root locus method
 (D) Nyquist criterion

Answer: (D)

77. Consider the following system:

$$\begin{bmatrix} \dot{x}_1(t) \\ \dot{x}_2(t) \end{bmatrix} = \begin{bmatrix} -0.5 & 0 \\ 0 & -2 \end{bmatrix} \begin{bmatrix} x_1(t) \\ x_2(t) \end{bmatrix} + \begin{bmatrix} 0 \\ 1 \end{bmatrix} u(t) \text{ and}$$

$$y(t) = \begin{bmatrix} 0 & 1 \end{bmatrix} \begin{bmatrix} x_1(t) \\ x_2(t) \end{bmatrix}$$

The system is

- (A) controllable and observable
 (B) uncontrollable only
 (C) unobservable only
 (D) uncontrollable and unobservable

Answer: (D)

78. Which one of the following is not correct with reference to proportional derivative (PD) controller ?
- (A) PD control action reduces rise time of the system
 (B) PD control action improves the damping system
 (C) PD control action decreases the bandwidth
 (D) PD control action reduces the overshoot

Answer: (C)

79. Consider the following statements for lag-lead compensator:

1. It is a combination of a lag compensator and a lead compensator.
2. The lag-section has one real pole and one real zero with the pole to the right of the zero.
3. The lead-section has one real pole and one real zero with the zero to the right of the pole.

Which the above statements are correct ?

- (A) 1 and 3 only
 (B) 2 and 3 only
 (C) 1 and 2 only
 (D) 1, 2, and 3

Answer: (D)

80. The ramp response for a system whose transfer

function $G(s) = \frac{s}{(s+4)(s+8)}$ is

- (A) $c(t) = \frac{1}{2}e^{-4t} + \frac{1}{2}e^{-8t}$
 (B) $c(t) = \frac{1}{2}e^{-4t} - \frac{1}{2}e^{-8t}$
 (C) $c(t) = \frac{1}{32} - \frac{1}{16}e^{-4t} + \frac{1}{32}e^{-8t}$
 (D) $c(t) = \frac{1}{32} - \frac{1}{12}e^{-4t} - \frac{1}{16}e^{-8t}$

Answer: (C)

81. In the figure, if $C(s)$ is the Laplace transform of the output and $R(s)$ is the Laplace transform of the input, the equivalent transfer function $T(s)$ is

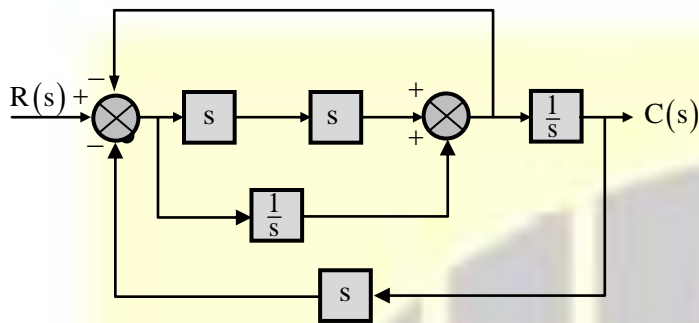

- (A) $T(s) = \frac{s^3 + 1}{2s^4 + s^2 + 2s}$
- (B) $T(s) = \frac{s^3 + 1}{2s^4 + s^2 - s}$
- (C) $T(s) = \frac{s^3 + 1}{2s^4 + s^2 + 1}$
- (D) $T(s) = \frac{s^3 - 1}{2s^4 + s^2 + 2}$

Answer: (A)

82. Consider the following statements related to stability of the control system :

1. Poles in right half-plane (rhp) yield pure exponential decaying natural response.
2. If poles of multiplicity greater than one are present on the imaginary axis, then the system is marginally stable.
3. If one pole is present in right-half plane, the system is unstable.
4. A system is stable if the natural response approaches zero as time approaches infinity.

Which of the above statements is/are not correct?

- (A) 1 and 4 only
- (B) 1 and 2 only
- (C) 1 only
- (D) 3 and 4 only

Answer: (B)

83. The state equation and the output equations of the system are as follows:

$$\dot{x} = \begin{bmatrix} 0 & 1 & 2 \\ 5 & 6 & 9 \\ 5 & 3 & 9 \end{bmatrix} x + \begin{bmatrix} 1 \\ 0 \\ 0 \end{bmatrix} u$$

$$y = [1 \ 0 \ 0]x$$

Where x is the state variable, u is the input variable and y is the output variable. What is the number of right-half poles?

- (A) 0 (B) 1 (C) 2 (D) 3

Answer: (C)

84. In minimum phase transfer function, the transfer functions have

- (A) neither poles nor zeros in the right-half s-plane.
- (B) poles in right-half a-plane and zeros in left-half s-plane.
- (C) poles in left-half s-plane and zeros in right-half s-plane.
- (D) poles and zeros in the right-half a-plane.

Answer: (A)

85. Which one of the following statements is not correct regarding lap and wave winding ?

- (A) Lap-winding is suitable for high-voltage but low-current generators.
- (B) Lap-winding is suitable for low-voltage but high-current generators.
- (C) Wave-winding is used for high-voltage, low-current machines.
- (D) When large currents are required, it is necessary to use lap-winding.

Answer: (A)

86. An 8-pole DC shunt generator with 778 wave-connected armature conductors and running at 500 rpm supplies a load of 12.5 resistance at terminal voltage of 250V. The armature resistance is 0.24Ω and field resistance is 250 Ω . The magnitude of armature current is
- (A) 20 A (B) 10A (C) 21 A (D) 11 A

Answer: (C)

87. A 12-pole, 3-phase alternator driven at a speed of 500 rpm, supplies power to an 8-pole, 3-phase induction motor. If the slip of the motor at full-load is 3%, what is the full-load speed of the motor?
- (A) 525.5 rpm
(B) 627.5 rpm
(C) 727.5 rpm
(D) 826.5 rpm

Answer: (C)

88. A 300 kVA, single-phase transformer is designed to have a resistance of 1.5% and maximum efficiency occurs at a load of 173.2

kVA. What is the efficiency when supplying full-load at 0.8 pf lagging at normal voltage and frequency?

- (A) 68.2% (B) 76.3%
(C) 89.1% (D) 97.6%

Answer: (D)

89. A sinusoidal flux 0.02 Wb links with 55 turns of a transformer secondary. What is the rms value of the induced emf in the secondary, if the supply frequency is 50 Hz?

- (A) 244.2 V
(B) 334.2 V
(C) 414.2 V
(D) 504.2 V

Answer: (A)

90. A stepper motor with a step angle of 15° has a stepping frequency of 300 steps/sec. What is the motor speed ?

- (A) 750 rpm
(B) 650 rpm
(C) 780 rpm
(D) 950 rpm

Answer: (A)

91. If P_1 and P_2 be the iron and copper losses of a transformer on full-load, what is the ratio of P_1 and P_2 such that maximum efficiency occurs at 75% full-load ?

- (A) 4/3 (B) 3/4 (C) 5/7 (D) 9/16

Answer: (D)

92. Which one of the following statements is *not* correct regarding simplex lap winding of a DC machine?

- (A) The total number of brushes is equal to the number of poles.
- (B) The number of parallel paths in the armature is two.
- (C) The emf between the positive and the negative brushes is equal to the emf generated in any one of the parallel paths.
- (D) If Z is the total number of armature conductors and P is the number of poles, then the number of armature conductors in any parallel path is Z/P .

Answer: (B)

93. The single-phase reluctance machine can be made to work as a generator when mechanical power is supplied to the shaft. This is possible when

- (A) mechanical power is increased and angle becomes negative.
- (B) mechanical power is increased and angle becomes positive.
- (C) mechanical power is decreased and angle becomes 60° .
- (D) mechanical power is decreased and angle becomes 45° .

Answer: (B)

94. If the flux linkage-current characteristic is linear, then

- (A) the field energy is greater than the coenergy.
- (B) the field energy is less than the coenergy.
- (C) the field energy is equal to the coenergy.
- (D) the field energy and the coenergy do not have any dependence on flux linkage-current characteristic.

Answer: (C)

95. An 8-pole generator has an output of 200 A at 500V, the lap-connected armature has 1280 conductors, 160 commutator segments. If the brushes are advanced 4-segments from the no-load neutral axis, what is the cross-magnetising ampere-turns per pole?

- (A) 1600
- (B) 1400
- (C) 1550
- (D) 1200

Answer: (D)

96. A 400 V, 1000 A, lap-wound DC machine has 10 poles and 860 armature conductors. What is the number of conductors in the pole face to give full compensation if the pole face covers 70% of the pole span?

- (A) 1000
- (B) 4000
- (C) 2050
- (D) 3010

Answer: (*)

97. The main function of electric power system is to

- (A) transmit energy with maximum efficiency
- (B) generate energy with minimum efficiency
- (C) store energy with maximum efficiency
- (D) convert energy with minimum efficiency

Answer: (A)

98. Which of the following are the sources of heat generation within the cables?

1. I^2R losses in the conductor.
2. Dielectric losses in the cable insulation.
3. Losses in the metallic sheath and armouring's.

Select the correct answer using the code given below:

- (A) 1 and 2 only
(B) 1,2 and 3
(C) 2 and 3 only
(D) 1 and 3 only

Answer: (B)

99. The radical distribution is simple and economical, but the reliability of the system is poor and leads to

- (A) evacuating of energy supply if there is fault in the line.
(B) transmission of energy supply if there is fault in the line.
(C) distribution of energy supply if there is fault in the line.
(D) interruption of energy supply if there is fault in the line.

Answer: (D)

100. Which one of the following statements is correct regarding fault analysis?

- (A) Balanced three-phase voltages contain zero-sequence components.
(B) Balanced three-phase voltages do not contain negative sequence components.

(C) Balanced three-phase voltages contain only negative sequence components.

(D) Balanced three-phase voltages contain positive and negative sequence components.

Answer: (B)

101. For a single-line to ground fault, the terminal conditions are

- (A) $V_a = 0, I_b = I_c = 0$
(B) $I_b = -I_c, V_a = V_c$
(C) $I_a = I_c, V_b = V_c$
(D) $I_a = 0, V_b = V_c$

Answer: (A)

102. The per unit impedance of a circuit element is x .

If the base kV and base MV A are doubled, then the new value of the per unit impedance of the circuit element is

- (A) x (B) $x/2$ (C) $2x$ (D) $x/4$

Answer: (B)

103. The fill factor of a photovoltaic module is 0.8. A

single cell in a module has an open circuit voltage of 0.6 V and short circuit current of 8A. The module has 48 cells connected in series. If the voltage at maximum power is 0.9 times open circuit voltage, the current at maximum power is

- (A) 8.21 A
(B) 7.11 A
(C) 6.32 A
(D) 5.45 A

Answer: (B)

104. The equivalent circuit of a photo voltaic module is presented below :

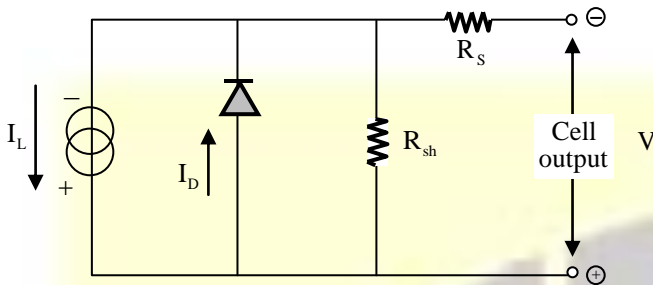

The requirements for more power production are

- (A) I_L should be maximum R_s should be large, R_{sh} should be small.
- (B) I_L should be maximum, R_s should be small, R_{sh} should be large.
- (C) I_L should be maximum, R_s should be small, R_{sh} should be large.
- (D) I_L should be minimum, R_s should be large, R_{sh} should be small.

Answer: (C)

105. Electricity supply systems are invariably three-phase and they are so designed and loaded that the operation is

- (A) star connected
- (B) balanced three-phase
- (C) unbalanced three-phase
- (D) delta connected

Answer: (B)

106. Which one of the following power plants is the least reliable?

- (A) Tidal
- (B) Solar
- (C) Wind
- (D) Geothermal

Answer: (C)

107. When a synchronous motor runs at no load with adjustable excitation over a wide range, power factor can be improved by varying the excitation of its

- (A) field winding
- (B) armature winding
- (C) commutator winding
- (D) compound winding

Answer: (A)

108. What is the maximum number of points of light, fans and 5 A socket outlets that can be in one circuit as per recommendation of Indian Standards ?

- (A) 8
- (B) 10
- (C) 12
- (D) 9

Answer: (B)

109. A DC supply of 100 V feeds an inductance of 10 H through a thyristor. What is the minimum width of the gate pulse so that the thyristor is triggered, if the latching current of thyristor is 80 mA ?

- (A) More than 8 ms
- (B) Less than 8 ms
- (C) Exact 6 ms
- (D) Less than 6 ms

Answer: (A)

110. Consider the following statements with regards to IGBTs :

1. At highest temperature, maximum current rating goes down to $2/3$ value.
2. IGBT is the preferred device for applications that require high blocking voltages and lower operating frequencies.
3. Turn-on transients are identical to MOSFETs.

Which of the above statements are correct ?

- (A) 1 and 2 only
(B) 2 and 3 only
(C) 1 and 3 only
(D) 1, 2 and 3

Answer: (C)

111. What is the supply frequency for the case hardening of shaft having specific resistivity of $5 \times 10^{-5} \Omega\text{-cm}$ and the relative permeability equal to 1 for depth of heating 2.5 mm?

- (A) 20.24 kHz
(B) 26.24 kHz
(C) 15.62 kHz
(D) 32.15 kHz

Answer: (A)

112. If $R_E=1k \Omega$, $V_E=2V$ and $I_V=5 \text{ mA}$, what is the value of V_{EE} which will cause the UJT to turn 'off' ?

- (A) 2 V (B) 5 V (C) 9 V (D) 7V

Answer: (A)

113. In a 110 V DC chopper drive using the CLC scheme, the maximum possible value of the accelerating current is 300 A. The lower limit of the current pulsation is 140 A. What is the maximum limit of current pulsation?

- (A) 140A (B) 440A (C) 160A (D) 150A

Answer: (B)

114. A three-phase, squirrel-cage induction motor is developing torque of 1500 sync.watts at 50 Hz and 1400 rpm (synchronous speed is 1500 rpm). If the motor frequency is now increased to 75Hz using constant power mode, what is the new value of torque developed by the motor at constant slip ?

- (A) 1500 sync. watts
(B) 7500 sync.watts
(C) 1000 sync.watts
(D) 2250 sync.watts

Answer: (C)

115. A UPS is driving a 600 W load which has a lagging power factor of 0.8. The efficiency of the inverter is 80%. The battery voltage is 24V DC. Assume that there is a separate charger for the battery. What is the rating of the inverter ?

- (A) 1.5kVA
(B) 0.5 kVA
(C) 0.75 kVA
(D) 2.5 kVA

Answer: (A)

116. A boost converter having an input voltage of 20V is connected to a resistive load. The value of inductance is 1 mH with an equivalent series resistance of 0.1Ω . If the duty ratio of the converter is one, then the output voltage is

- (A) zero
- (B) 20V
- (C) 40V
- (D) infinite

Answer: (A)

117. In comparing the operation of the half-controlled 2-pulse circuit with that of the fully-controlled circuit, which of the following statements are evident?

1. Since half the thyristors are replaced by diodes, a half-controlled converter costs less than a fully-controlled converter.
2. Due to the freewheeling action with half-controlled bridge-circuit power factor is improved in half-controlled converters.
3. The AC supply current is more distorted due to its zero periods with half-controlled circuit, compared to fully-controlled bridge-circuit.

Select the correct answer using the code given below:

- (A) 1 and 2 only
- (B) 2 and 3 only
- (C) 1 and 3 only
- (D) 1, 2 and 3

Answer: (A)

118. A DC chopper circuit connected to a 100 V DC source supplies an inductive load having 40 mH in series with a resistance of 5Ω . A freewheeling diode is placed across the load. The load current varies between the limits of 10A and 12A. What is the time ratio of the chopper?

- (A) 12.22
- (B) 1.222
- (C) 2.111
- (D) 21.11

Answer: (B)

119. What is the minimum capacitance for the supply transformer rated 5 kVA with secondary voltage of 120V RMS and switching frequency of 400 Hz?

- (A) $0.92\ \mu\text{F}$
- (B) $0.76\ \mu\text{F}$
- (C) $0.52\ \mu\text{F}$
- (D) $0.25\ \mu\text{F}$

Answer: (*)

120. A 220 V, 960 rpm, 80 A separately excited DC motor has an armature resistance 0.06Ω . Under rated conditions, the motor is driving a load whose torque is constant and independent of speed. The speeds below the rated speed are obtained with armature voltage control and the speeds above the rated speed are obtained by field control. What is the motor terminal voltage, when the speed is 620 rpm?

- (A) 68.98 V
- (B) 143.78V
- (C) 215.22 V
- (D) 320.11 V

Answer: (B)

121. The function of an AM detector is to demodulate the AM signal and recover

- (A) the original source information with same frequencies and same relative amplitude characteristics.
- (B) the original source information with up-converted frequencies.
- (C) the original signal with amplified output voltage.
- (D) the original source information with various frequencies and different amplitude characteristics.

Answer: (A)

122. Which one of the following statements is correct for the active filter using op-amps ?

- (A) High frequency response is limited by the gain bandwidth product and slew-rate of the op-amp.
- (B) Op-amps are not providing any gain.
- (C) Due to the low input impedance of the op-amp, large value resistors can be used.
- (D) High frequency active filters are not more expensive than passive filters.

Answer: (A)

123. What is the value of the full scale output for an 8-bit digital to analog converter for 0V to 10V range?

- (A) 6.961 V
- (B) 7.891V
- (C) 8.961 V
- (D) 9.961 V

Answer: (D)

124. Lead frequency compensation is a technique used to increase

- (A) the phase margin
- (B) the gain
- (C) the bandwidth
- (D) the slew rate

Answer: (A)

125. Which one of the following is not correct for the AAA instruction in 8086 microprocessors ?

- (A) It works only on the AL register
- (B) It updates AF and CF
- (C) It checks the result for correct unpacked BCD
- (D) It updates all the flags

Answer: (D)

126. Which one of the following filters is used to recover original signal from its sample?

- (A) Low pass filter
- (B) High pass filter
- (C) Band pass filter
- (D) Band reject filter

Answer: (A)

127. In the first order low pass filter, which one of the following statements is *not* correct?

- (A) It has the maximum gain at frequency of 0 Hz.
- (h) At higher cut off frequency, the gain falls to 0.707 times the maximum gain.
- (C) For frequency greater than higher cut off frequency, the gain decreases at a constant rate of -20 dB/decade.
- (D) It has the maximum gain in stop band.

Answer: (D)

128. The quantization error is equivalent to

- (A) internal noise generated within system
- (B) impulse noise.
- (C) inter modulation noise as it produces harmonics.
- (D) additive white noise as it alters the signal amplitude.

Answer: (A)

129. A frequency division multiplexing system is used to multiplex 24 independent voice signals. Single sideband modulation is used for the transmission. Each voice signal is allotted a bandwidth of 4 kHz. What is the overall transmission bandwidth of the channel?

- (A) 4 kHz
- (B) 6 kHz
- (C) 24 kHz
- (D) 96 kHz

Answer: (D)

130. A Time Division Multiplexing system is used to multiplex four independent voice signals using pulse amplitude modulation. Each voice signal is sampled at the rate of 8 kHz. The system incorporates a synchronizing pulse train for its proper operation. What is the timing between the synchronizing pulse trains and the impulse trains used to sample the four voice signals ?

- (A) $5\mu\text{s}$
- (B) $10\mu\text{s}$
- (C) $15\mu\text{s}$
- (D) $25\mu\text{s}$

Answer: (D)

131. Which one of the following statements is correct for full amplitude modulation?

- (A) The spectrum consists of two sidebands(one termed the upper sideband and the other termed the lower sideband).
- (B) The spectrum consists of one sideband(termed the upper sideband).
- (C) The spectrum consists of one sideband(termed the lower sideband).
- (D) The spectrum consists of three sidebands (one termed the upper sideband, the second termed the lower sideband, and the third termed the lowest sideband).

Answer: (A)

132. The highest frequency component of a speech signal needed for telephonic communications is about 3.1 kHz. What is the suitable value for the sampling rate ?

- (A) 1 kHz
- (B) 2 kHz
- (C) 4 kHz
- (D) 8 kHz

Answer: (D)

133. Which one of the following is the advantage of FIR filter over IIR filter?

- (A) FIR filter can have an exact linear phase.
- (B) FIR filter is always unstable.
- (C) For FIR filter, the design methods are non-linear.
- (D) FIR filter cannot be realized efficiently in hardware.

Answer: (A)

134. Consider the following statements for a periodic signal:

1. Both the magnitude and phase spectra are line spectra.
2. For real-valued signals, the magnitude spectrum has even symmetry.
3. For real-valued signals, the phase has odd symmetry.

Which of the above statements are correct ?

- (A) 1 and 2 only
- (B) 1, 2 and 3
- (C) 2 and 3 only
- (D) 1 and 3 only

Answer: (B)

135. Consider the following statements regarding power of a continuous-time and discrete-time signals:

1. Power is the time average of energy.
2. A signal with finite energy has zero power.
3. A signal with finite power has infinite energy

4. All finite periodic signals are power signals.

Which of the above statements are correct ?

- (A) 1,2, 3 and 4
- (B) 1, 2 and 3 only
- (C) 2,3 and 4 only
- (D) 1 and 4 only

Answer: (A)

136. Which one of the following filters is used for reduction of power line harmonics, suppression of clutter from fixed objects in moving target indication radar?

- (A) NOTCH filter
- (B) IIR filter
- (C) FIR filter
- (D) COMB filter

Answer: (D)

137. For $z_1 = 2e^{j\pi/4}$ and $z_2 = 8e^{j\pi/3}$, the value of $\frac{z_1}{z_2^2}$ is

- (A) $e^{-j\frac{5\pi}{12}}$
- (B) $\frac{1}{8}e^{-j\frac{6\pi}{17}}$
- (C) $\frac{1}{32}e^{-j\frac{5\pi}{12}}$
- (D) $\frac{1}{14}e^{-j\frac{5\pi}{17}}$

Answer: (C)

138. The simplified value of $\int x^2 \cos ax \, dx$ is

- (A) $\frac{1}{a^3}(2ax \cos ax - 2 \sin ax + a^2 x^2 \sin ax)$
- (B) $\frac{1}{a^2}(2ax \cos ax - 2 \sin ax + a^2 x \sin ax)$
- (C) $\frac{1}{a}(2ax \cos ax - 2 \sin ax + ax \sin ax)$
- (D) $\frac{1}{a}(2ax \cos ax - 2 \sin ax + a^2 x^2 \sin ax)$

Answer: (A)

139. What is the total average power in the unit-amplitude square wave of period, T, and 50% duty cycle?

- (A) 1.5 (B) 0.25 (C) 0.5 (D) 1

Answer: (C)

140. For a system with unit impulse response $h[k] = (0.5)^k u[k]$, what is the zero state response $y[k]$ for the input $f[k] = (0.8)^k u[k]$?

- (A) $y[k] = \left[-\frac{2}{3}(0.5)^k + \frac{7}{3}(0.6)^k \right] u[k]$
 (B) $y[k] = \left[-\frac{5}{3}(0.5)^k + \frac{8}{3}(0.8)^k \right] u[k]$
 (C) $y[k] = \left[-\frac{1}{3}(0.5)^k + \frac{2}{3}(0.8)^k \right] u[k]$
 (D) $y[k] = \left[-(0.5)^k + (0.6)^k \right] u[k]$

Answer: (B)

141. The value of $\int x^2 e^{ax} dx$ is

- (A) $\frac{e^{ax}}{a} (a^2 x^2 + 3ax - 2)$
 (B) $\frac{e^{ax}}{a^4} (a^3 x^2 - a^2 x + 2ax + 1)$
 (C) $\frac{e^{ax}}{a^3} (a^2 x^2 - 2ax + 2)$
 (D) $\frac{e^{ax}}{a^2} (a^3 x^2 - 2a^2 x + 2ax + 4)$

Answer: (C)

142. What is the convolution $y[n] = x[n] * h[n]$:

where $x[n] = \alpha^n u[n]$, $h[n] = \beta^n u[n]$, $\alpha \neq \beta$,
 $\alpha = 0.8$, $\beta = 0.9$?

(A) $y[n] = [9(0.9)^n - 8(0.8)^n] u[n]$

(B) $y[n] = [0.9(9)^n - 0.8(8)^n] u[n]$

(C) $y[n] = [0.3(9)^n - 0.4(8)^n] u[n]$

(D) $y[n] = [9(0.3)^n - 8(0.4)^n] u[n]$

Answer: (A)

143. Which one of the following is correct for Parseval equality ?

(A) $\int_{-\infty}^{+\infty} |x(t)|^2 dt = \frac{1}{2\pi} \int_{-\infty}^{+\infty} |X(j\omega)|^2 d\omega$

(B) $\int_{-\infty}^{+\infty} |x(t)|^2 dt = \frac{1}{2\pi} \int_{-\infty}^{+\infty} |X(j\omega)|^{1/2} d\omega$

(C) $\int_{-\infty}^{+\infty} |x(t)|^2 dt = \frac{1}{\pi} \int_0^{+\infty} |X(j\omega)|^{1/2} d\omega$

(D) $\int_{-\infty}^{+\infty} |x(t)|^2 dt = \frac{4}{3\pi} \int_{-\infty}^{+\infty} |X(j\omega)|^2 d\omega$

Answer: (A)

144. For $x(t) = \sin(10\pi t) / \pi t$, what is the condition on the sampling interval T so that $x(t)$ is uniquely represented by the discrete-time sequence $x[n] = x(nT)$?

(A) $T < 1/10$

(B) $T < 1/5$

(C) $T > 1/5$

(D) $T > 1/10$

Answer: (A)

Directions: Each of the next six (6) items consists of two statements, one labelled as the 'Statement (I)' and the other labelled as Statement (II). You are to examine these two statements carefully and select the answers to these items using the codes given below:

Codes:

- (A) Both Statement (I) and Statement (II) are individually true and Statement (II) is the correct explanation of Statement (I).
- (B) Both Statement (I) and Statement (II) are individually true, but Statement (II) is not the correct explanation of Statement (I).
- (C) Statement (I) is true, but Statement (II) is false.
- (D) Statement (I) is false, but Statement (II) is true.

145. Statement (I): Ferromagnetic properties are confined almost entirely to iron, nickel and cobalt and their alloys.

Statement (II): By substituting the basic ferrite of magnetite with other divalent oxides, a wide range of ferrimagnetic compounds with useful properties can be produced, which have high electrical resistivity to minimize eddy currents at high frequencies.

Answer: (B)

146. Statement (I): The inorganic materials are used to manufacture suspension insulators for high-voltage overhead lines and bushings on high-voltage transformers and switchgear.

Statement (II): The ceramic and glass materials are formed into a series of flanged discs to decrease the creepage distance along the surface of the complete insulator.

Answer: (B)

147. Statement (I): In resonant circuits, the capacitor voltage or inductor current could be much lower than the source voltage or source current, and a large input signal can produce a small output signal when resonance appears in a circuit.

Statement (II): In resonant circuits, the quality factor for a coil is defined as the ratio of the inductive reactance and the winding resistance, which is a dimensionless parameter.

Answer: (D)

148. Statement (I): The pattern of the electric field lines strongly depends on the geometric arrangement of charge carriers and the field lines always enter or exit the charge carrier vertically.

Statement (II): From the field pattern, a small distance between adjacent field lines (high field line density) indicates low field strength.

Answer: (C)

149. Statement (I): A strain gauge pressure sensor converts the physical quantity "pressure" into an electrical signal and electrical resistance of the strain gauge changes with the tensile strain.

Statement (II): Bourdon tube pressure sensors work on the principle of change of any form of deformation, the cross-sectional tubing tends to recover its circular form under the action of pressure, which is used as mechanical pressure measuring instrument.

Answer: (B)

150. Statement (I): Lightly doped n⁻ epitaxial layer is present in pn-junction diode.

Statement (II): Power diodes have lightly doped n⁻ epitaxial layer which can absorb the depletion layer during reverse biased.

Answer: (A)