

*GATE PREVIOUS YEAR SOLVED PAPERS*  
**Chemical Engineering  
Previous Year Solved Papers**

**GATEFORUM** Pioneers in Digital courses for GATE since 2008 has long history of training students through innovative courses. Currently GATEFORUM offers a wide range of courses from eGATE, GATE Online, Gdrive to Online TarGATE. Since inception, we have trained more 3,00,000 students since inception.

**For more details visit [gateforumonline.com](http://gateforumonline.com)**

**GENERAL APTITUDE****Q. No. 1 - 5 Carry One Mark Each**

1. Inhaling the smoke from a burning \_\_\_\_\_ could \_\_\_\_\_ you quickly.  
(A) tire / tier                      (A) tire / tyre                      (C) tyre / tire                      (D) tyre / tier

**Answer: (C)**

[Click here to watch video explanation](#)

2. A sphere of radius  $r$  cm is packed in a box of cubical shape.  
What should be the minimum volume (in  $\text{cm}^3$ ) of the box that can enclose the sphere?

- (A)  $\frac{r^3}{8}$                       (A)  $r^3$                       (C)  $2r^3$                       (D)  $8r^3$

**Answer: (D)**

[Click here to watch video explanation](#)

3. Pipes P and Q can fill a storage tank in full with water in 10 and 6 minutes, respectively. Pipe R draws the water out from the storage tank at a rate of 34 litres per minute. P, Q and R operate at a constant rate. If it takes one hour to completely empty a full storage tank with all the pipes operating simultaneously, what is the capacity of the storage tank (in litres)?

- (A) 26.8                      (A) 60.0                      (C) 120.0                      (D) 127.5

**Answer: (C)**

[Click here to watch video explanation](#)

4. Six persons P, Q, R, S, T and U are sitting around a circular table facing the center not necessarily in the same order. Consider the following statements:

- P sits next to S and T.
- Q sits diametrically opposite to P.
- The shortest distance between S and R is equal to the shortest distance between T and U.

Based on the above statements, Q is a neighbor of

- (A) U and S                      (A) R and T                      (C) R and U                      (D) P and S

**Answer: (C)**

[Click here to watch video explanation](#)

5. A building has several rooms and doors as shown in the top view of the building given below. The doors are closed initially.

What is the minimum number of doors that need to be opened in order to go from the point P to the point Q?

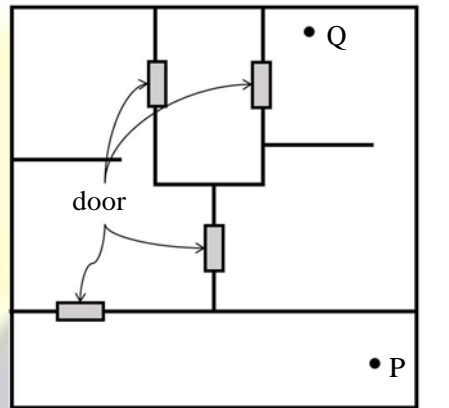

- (A) 4                      (A) 3                      (C) 2                      (D) 1

**Answer: (C)**

[Click here to watch video explanation](#)

**Q.No. 6–10 Carry Two Marks Each**

6. Rice, a versatile and inexpensive source of carbohydrate, is a critical component of diet worldwide. Climate change, causing extreme weather, poses a threat to sustained availability of rice. Scientists are working on developing Green Super Rice (GSR), which is resilient under extreme weather conditions yet gives higher yields sustainably.

Which one of the following is the CORRECT logical inference based on the information given in the above passage?

- (A) GSR is an alternative to regular rice, but it grows only in an extreme weather  
(A) GSR may be used in future in response to adverse effects of climate change  
(C) GSR grows in an extreme weather, but the quantity of produce is lesser than regular rice  
(D) Regular rice will continue to provide good yields even in extreme weather

**Answer: (B)**

[Click here to watch video explanation](#)

7. A game consists of spinning an arrow around a stationary disk as shown below. When the arrow comes to rest, there are eight equally likely outcomes. It could come to rest in any one of the sectors numbered 1, 2, 3, 4, 5, 6, 7 or 8 as shown. Two such disks are used in a game where their arrows are independently spun. What is the probability that the sum of the numbers on the resulting sectors upon spinning the two disks is equal to 8 after the arrows come to rest?

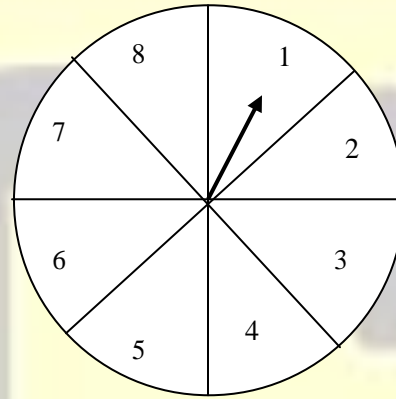
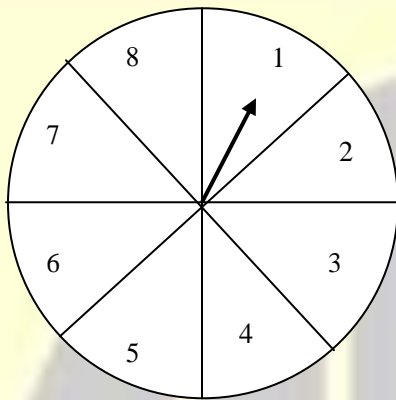

(A)  $\frac{1}{16}$

(A)  $\frac{5}{64}$

(C)  $\frac{3}{32}$

(D)  $\frac{7}{64}$

**Answer: (D)**

[Click here to watch video explanation](#)

8. Consider the following inequalities.

(i)  $3p - q < 4$

(ii)  $3q - p < 12$

Which one of the following expressions below satisfies the above two inequalities?

(A)  $p + q < 8$

(A)  $p + q = 8$

(C)  $8 \leq p + q < 16$

(D)  $p + q \geq 16$

**Answer: (A)**

[Click here to watch video explanation](#)

9. Given below are three statements and four conclusions drawn based on the statements.

**Statement 1:** Some engineers are writers.

**Statement 2:** No writer is an actor.

**Statement 3:** All actors are engineers.

**Conclusion I:** Some writers are engineers.

**Conclusion II:** All engineers are actors.

**Conclusion III:** No actor is a writer.

**Conclusion IV:** Some actors are writers.

Which one of the following options can be logically inferred?

- (A) Only conclusion I is correct
- (A) Only conclusion II and conclusion III are correct
- (C) Only conclusion I and conclusion III are correct
- (D) Either conclusion III or conclusion IV is correct

**Answer:** (C)

[Click here to watch video explanation](#)

10. Which one of the following sets of pieces can be assembled to form a square with a single round hole near the center? Pieces cannot overlap.

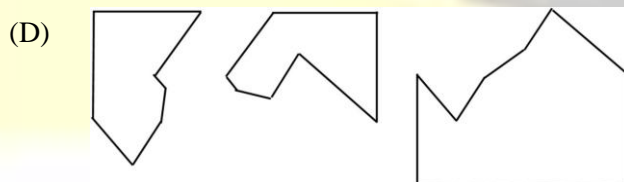
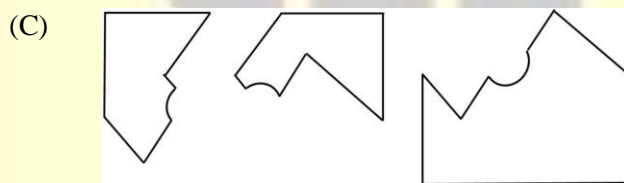
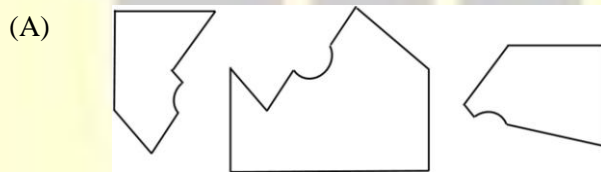
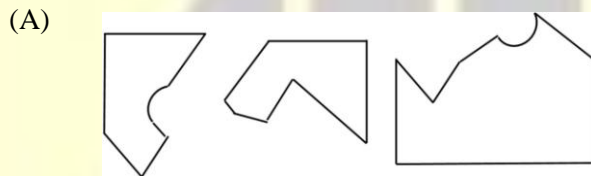

**Answer:** (C)

[Click here to watch video explanation](#)

**CHEMICAL ENGINEERING**

**Q. No. 11-35 Carry One Mark Each**

11. The value of  $(1+i)^{12}$ , where  $i = \sqrt{-1}$  is

- (A) -64i                      (A) 64i                      (C) 64                      (D) -64

**Answer: (D)**

[Click here to watch video explanation](#)

12. Given matrix  $A = \begin{bmatrix} x & 1 & 3 \\ y & 2 & 6 \\ 3 & 5 & 7 \end{bmatrix}$  the ordered pair (x,y) for which  $\det(A)=0$  is

- (A) (2, 1)                      (A) (1,2)                      (C) (2, 2)                      (D) (1, 1)

**Answer: (B)**

[Click here to watch video explanation](#)

13. Let  $f(x) = e^{-|x|}$ , where x is real. The value of  $\frac{df}{dx}$  at  $x = -1$  is

- (A) e                      (A) 1/e                      (C) -1/e                      (D) -e

**Answer: (B)**

[Click here to watch video explanation](#)

14. The value of the real variable  $x \geq 0$ , which maximizes the function  $f(x) = x^e e^{-x}$  is

- (A) 0                      (A) e                      (C) 1                      (D) 1/e

**Answer: (B)**

[Click here to watch video explanation](#)

15. For a single component system at vapor-liquid equilibrium, the extensive variables A, V, S and N denote the Helmholtz free energy, volume, entropy, and number of moles, respectively, in a given phase. If superscripts (v) and (l) denote the vapor and liquid phase, respectively, the relation that is NOT CORRECT is

- (A)  $\left(\frac{\partial A^{(l)}}{\partial V^{(l)}}\right)_{T,N^{(l)}} = \left(\frac{\partial A^{(v)}}{\partial V^{(v)}}\right)_{T,N^{(v)}}$                       (A)  $\left(\frac{A+TS}{N}\right)^{(l)} = \left(\frac{A+TS}{N}\right)^{(v)}$
- (C)  $\left(\frac{A+PV}{N}\right)^{(l)} = \left(\frac{A+PV}{N}\right)^{(v)}$                       (D)  $\left(\frac{\partial A^{(l)}}{\partial N^{(l)}}\right)_{T,V^{(l)}} = \left(\frac{\partial A^{(v)}}{\partial N^{(v)}}\right)_{T,V^{(v)}}$

**Answer: (C)**

[Click here to watch video explanation](#)

16. Consider turbulent flow in a pipe under isothermal conditions. Let  $r$  denote the radial coordinate and  $z$  denoted the axial flow direction. On moving away from the wall towards the center of the pipe, the  $rz$ -component of the Reynolds stress
- (A) Only increases  
(C) Remains unchanged
- (A) Decreases and then increases  
(D) Increases and then decreases

**Answer: (D)**

[Click here to watch video explanation](#)

17. Consider two stationary spherical pure water droplets of diameters  $d_1$  and  $2d_1$ .  $\text{CO}_2$  diffuses into the droplets from the surroundings. If the rate of diffusion of  $\text{CO}_2$  into the smaller droplet is  $W_1 \text{ mol s}^{-1}$ , the rate of diffusion of  $\text{CO}_2$  into the larger droplet is
- (A)  $W_1$                       (B)  $2W_1$                       (C)  $4W_1$                       (D)  $0.5W_1$

**Answer: (B)**

[Click here to watch video explanation](#)

18. In soap manufacturing, the triglycerides present in oils and fats are hydrolyzed to mainly produce
- (A) Glycerol only  
(C) Fatty acids and glycerol
- (A) Glycerol and paraffins  
(D) Fatty acids only

**Answer: (C)**

[Click here to watch video explanation](#)

19. The chemical formula of Glauber's salt, used in the Kraft process, is
- (A)  $\text{Na}_2\text{CO}_3 \cdot 10\text{H}_2\text{O}$                       (B)  $\text{Na}_2\text{HPO}_4 \cdot 2\text{H}_2\text{O}$   
(C)  $\text{Na}_2\text{S}_2\text{O}_4 \cdot 2\text{H}_2\text{O}$                       (D)  $\text{Na}_2\text{SO}_4 \cdot 10\text{H}_2\text{O}$

**Answer: (D)**

[Click here to watch video explanation](#)

20. Catalytic reforming is commonly used in the petroleum industry to improve fuel quality. The undesirable reaction in the catalytic reforming of naphtha is
- (A) Cyclization of paraffins  
(A) Hydrocracking of paraffins  
(C) Dehydrogenation of naphthenes  
(D) Isomerization of naphthenes

**Answer: (B)**

[Click here to watch video explanation](#)

21. A control system on the jacket side of a reactor is shown in the figure. Pressurized water flows through the jacket to cool the reactor. The heated water flashes in the boiler. The exothermic reaction heat thus generates steam. Fresh boiler feed water (BFW) is added to make-up for the loss of water as steam. Assume that all control valves are air-to-open. The controller action, 'direct' or 'reverse', is defined with respect to the controller. Select the option that correctly specifies the action of the controllers.

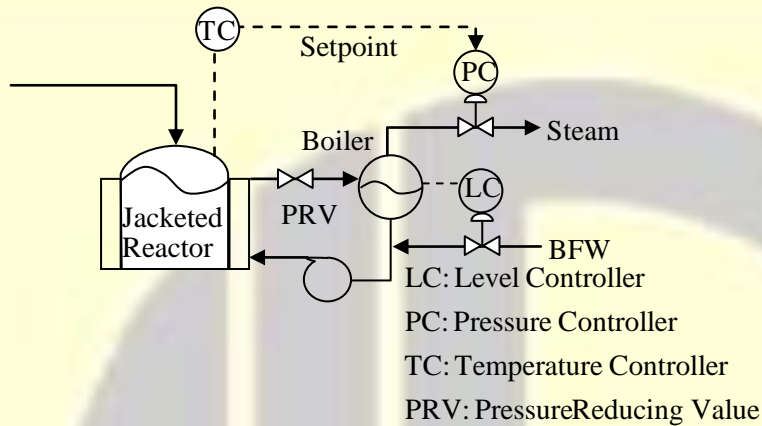

- (A) PC : Reverse, LC : Direct, TC : Direct      (A) PC : Direct, LC : Reverse, TC : Reverse  
 (C) PC : Direct, LC : Reverse, TC : Direct      (D) PC: Reverse, LC: Direct, TC: Reverse

**Answer: (B)**

[Click here to watch video explanation](#)

22. Liquid flowing through a heat exchanger (HX) is heated. A bypass stream is provided to control the temperature of the heated exit stream. From the given plumbing options, the one that provides the most effective temperature control for large disturbances while avoiding vaporization in the heat exchanger is

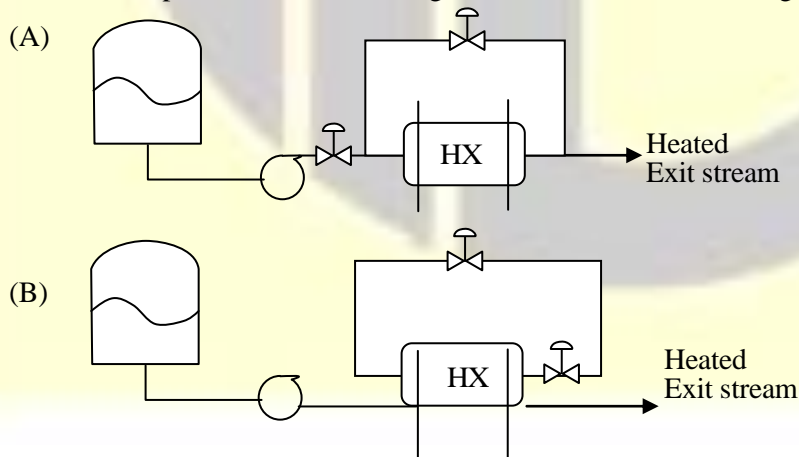



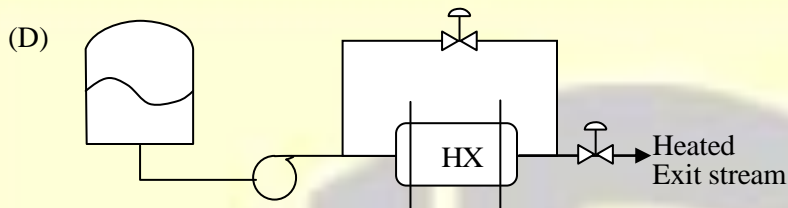
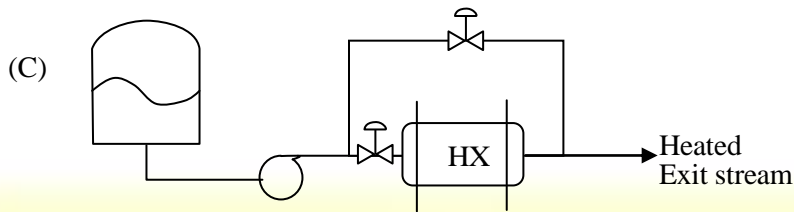

**Answer: (D)**

[Click here to watch video explanation](#)

23. The appropriate feedforward compensator,  $G_{ff}$ , in the shown block diagram is

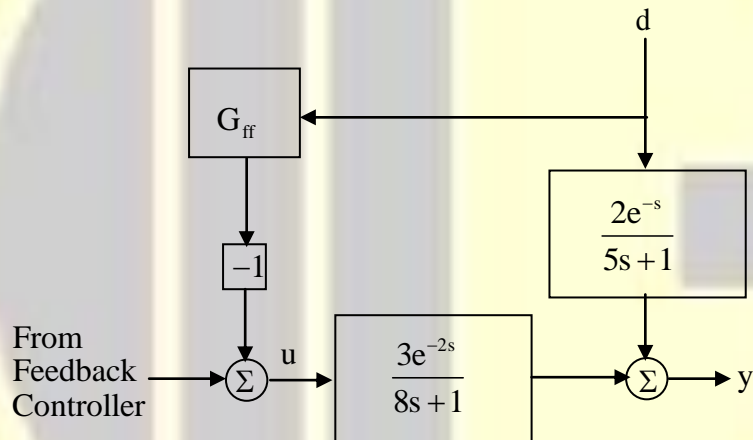

(A)  $G_{ff} = -\frac{2(8s+1)}{3(5s+1)}$

(A)  $G_{ff} = \frac{3(5s+1)}{2(8s+1)}e^{-s}$

(C)  $G_{ff} = -\frac{3(5s+1)}{2(8s+1)}e^{-1}$

(D)  $G_{ff} = \frac{2(8s+1)}{3(5s+1)}$

**Answer: (A)**

[Click here to watch video explanation](#)

24. Choose the option that correctly pairs the given measurement devices with the quantities they measure.

S No	Measurement Device	S No	Measured Quantity
I	Bourdon Gauge	A	Temperature
II	Orifice Plate meter	B	Concentration
III	Pyrometer	C	Pressure
IV	Colorimeter	D	Flow rate
V	Pirani Gauge	E	Liquid level

- (A) I-D II-C III-A IV – E V-C  
 (C) I-E II-C III-D IV-B V-A  
 (A) I-C II-D III-A IV-B V-C  
 (D) I-C II-D III-E IV-A V-D

**Answer: (B)**

[Click here to watch video explanation](#)

25. A simple distillation column is designed to separate an ideal binary mixture to specified distillate and bottoms purities at a given column pressure. If  $RR_{min}$ , is the minimum reflux ratio for this separation, select the statement that is **NOT CORRECT** with regard to the variation in the total annualized cost (TA(C) of the column with reflux ratio (RR).

- (A) TAC increases with RR for  $RR \gg RR_{min}$ .  
 (A) The sharpest rise in TAC occurs as RR approaches  $RR_{min}$ , from above  
 (C) The sharpest decrease in TAC occurs as RR approaches  $RR_{min}$  from above  
 (D) TAC has a minimum with respect to RR

**Answer: (B)**

[Click here to watch video explanation](#)

26. The reaction  $A \rightarrow B$  is carried out isothermally on a porous catalyst. The intrinsic reaction rate is  $kC_A^2$ , where k is the rate constant and  $C_A$  is the concentration of A. If the reaction is strongly pore-diffusion controlled, the observed order of the reaction is

- (A) 3/2                      (A) 1                      (C)  $\sqrt{2}$                       (D) 2

**Answer: (A)**

[Click here to watch video explanation](#)

27. In an enzymatic reaction, an inhibitor (I) competes with the substrate (S) to bind with the enzyme (E), thereby reducing the rate of product (P) formation. The competitive inhibition follows the reaction mechanism shown below. Let [S] and [I] be the concentration of S and I, respectively, and  $r_s$  be the rate of consumption of S. Assuming pseudo-steady state, the correct plot of  $\frac{1}{-r_s}$  vs  $\frac{1}{[S]}$  is

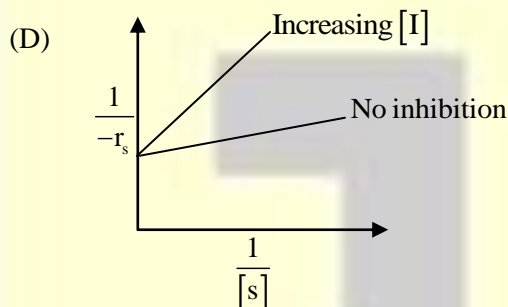
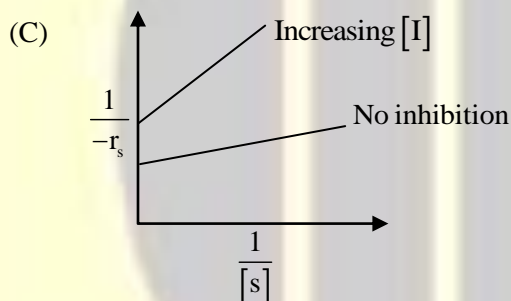
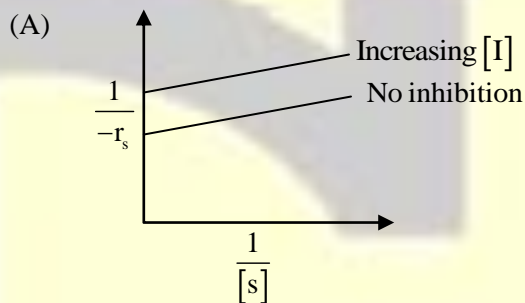
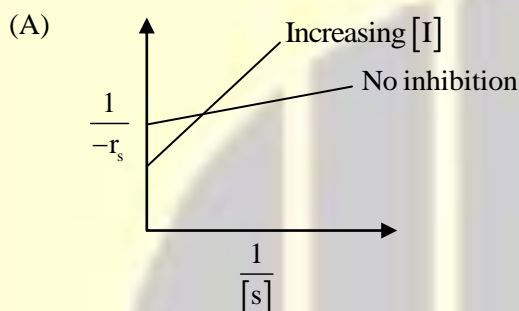
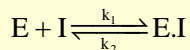

**Answer: (D)**

[Click here to watch video explanation](#)

28. The area of a circular field is  $25\text{m}^2$ . The radius,  $r$ , is to be determined using the Newton-Raphson iterative method. For an initial guess of  $r = 2.500$  m, the revised estimate of  $r$  after one iteration is \_\_\_\_\_ m (rounded off to three decimal places).

**Answer: (2.830 to 2.850)**

[Click here to watch video explanation](#)

29. 5 moles of liquid benzene, 8 moles of liquid toluene and 7 moles of liquid xylene are mixed at  $25^\circ\text{C}$  and 1 bar. Assuming the formation of an ideal solution and using the universal gas constant  $R = 8.314\text{J mol}^{-1} \text{K}^{-1}$ , the total entropy change is \_\_\_\_\_  $\text{JK}^{-1}$  (rounded off to one decimal place).

**Answer: (178.7 to 180.7)**

[Click here to watch video explanation](#)

30. A perfectly insulated double pipe heat exchanger is operating at steady state. Saturated steam enters the inner pipe at 100°C and leaves as saturated water at 100°C. Cooling water enters the outer pipe at 75°C and exits at 95 °C. The overall heat transfer coefficient is 1 kW m<sup>-2</sup> K<sup>-1</sup> and the heat transfer area is 1 m<sup>2</sup>. The average specific heat capacity of water at constant pressure is 4.2 kJ kg<sup>-1</sup>K<sup>-1</sup>. The required cooling water flow rate is kg s<sup>-1</sup> (rounded off to two decimal places).

**Answer:** (0.14 to 0.15)

[Click here to watch video explanation](#)

31. Consider steady-state diffusion in a binary A-B liquid at constant temperature and pressure. The mole-fraction of A at two different locations is 0.8 and 0.1. Let  $N_{A1}$  be the diffusive flux of A calculated assuming B to be non-diffusing, and  $N_{A2}$  be the diffusive flux of A calculated assuming equimolar counter-diffusion. The quantity  $\frac{(N_{A1} - N_{A2})}{N_{A1}} \times 100$  is \_\_\_\_\_ (rounded off to one decimal place).

**Answer:** (53 to 54)

[Click here to watch video explanation](#)

32. Consider interphase mass transfer of a species S between two immiscible liquids A and B. The interfacial mass transfer coefficient of S in liquid A is twice of that in liquid B. The equilibrium distribution of S between the liquids is given by  $y_S^A = 0.5y_S^B$  where  $y_S^A$  and  $y_S^B$  are the mole-fractions of S in A and B, respectively. The bulk phase mole-fraction of S in A and B is 0.10 and 0.02, respectively. If the steady-state flux of S is estimated to be 10 kmol h<sup>-1</sup> m<sup>-2</sup>, the mass transfer coefficient of S in A is \_\_\_\_\_ kmol h<sup>-1</sup> m<sup>-2</sup> (rounded off to one decimal place).

**Answer:** (221.0 to 223.0)

[Click here to watch video explanation](#)

33. A wet solid containing 20% (w/w) moisture (based on mass of bone-dry solid) is dried in a tray-dryer. The critical moisture content of the solid is 10% (w/w). The drying rate (kg m<sup>-2</sup>s<sup>-1</sup>) is constant for the first 4 hours, and then decreases linearly to half the initial value in the next 1 hour. At the end of 5 hours of drying. The percentage moisture content of the solid is \_\_\_\_\_%(w/w) (rounded off to one decimal place).

**Answer:** (8.0 to 8.4)

[Click here to watch video explanation](#)



**GATEFORUM**  
Engineering Success

*GATE REFRESHER COURSE*  
Chemical Engineering

**GATEFORUM** Pioneers in Digital courses for GATE since 2008 offers **GATE refresher course** giving you access to video solutions for previous 11 years GATE questions and Topic-wise formula Compendium (Handbook).

**Enroll now and get 20% discount use  
Promo Code **GATEPAPERS****

**For more details visit [gateforumonline.com](http://gateforumonline.com)**

34. A process described by the transfer function  $G_p(s) = \frac{(10s+1)}{(5s+1)}$

is forced by a unit step input at time  $t=0$ . The output value immediately after the step input (at  $t=0^+$ ) is \_\_\_\_\_ (rounded off to the nearest integer).

**Answer: (2 to 2)**

[Click here to watch video explanation](#)

35. A compressor with a life of 10 years costs Rs. 10 lakhs. Its yearly operating cost is Rs. 0.5 lakh. If the annual compound interest rate is 8%. The amount needed at present to fund perpetual operation of the compressor is Rs \_\_\_\_\_ lakhs (rounded to decimal place).

**Answer: (24.7 to 25.1)**

[Click here to watch video explanation](#)

**Q.No. 36-65 Carry Two Marks Each**

36. The partial differential equation

$$\frac{\partial u}{\partial t} = \frac{1}{\pi^2} \frac{\partial^2 u}{\partial x^2}$$

Where,  $t \geq 0$  and  $x \in [0,1]$ , is subjected to the following initial and boundary conditions:

$$u(x,0) = \sin(\pi x)$$

$$u(0,t) = 0$$

$$u(1,t) = 0$$

The value of  $t$  at which  $\frac{u(0.5,t)}{u(0.5,0)} = \frac{1}{e}$  is

(A)  $1/e$

(A) 1

(C)  $e$

(D)  $\pi$

**Answer: (B)**

[Click here to watch video explanation](#)

37.  $N$  moles of an ideal gas undergo a two-step process as shown in the figure. Let  $P$ ,  $V$  and  $T$  denote the pressure, volume and temperature of the gas, respectively. The gas, initially at state-I ( $P_1, V_1, T_1$ ), undergoes an isochoric (constant volume) process to reach state-A, and then undergoes an isobaric (constant pressure) expansion to reach state-2 ( $P_2, V_2, T_2$ ). For an ideal gas,  $C_p - C_v = NR$ , where  $C_p$  and  $C_v$  are the heat capacities at constant pressure and constant volume, respectively, and assumed to be temperature independent. The heat gained by the gas in the two-step process is given by

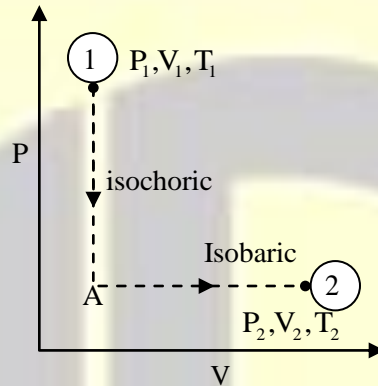

- (A)  $P_2V_2 - P_1V_1$  (A)  $C_p(T_2 - T_1) + C_v(T_2 - T_1)$   
 (C)  $P_2(V_2 - V_1) + C_p(T_2 - T_1)$  (D)  $P_2(V_2 - V_1) + C_v(T_2 - T_1)$

**Answer: (D)**

[Click here to watch video explanation](#)

38. A horizontal cylindrical water jet of diameter  $D_1 = 2$  cm strikes a vertical solid plate with a hole of diameter  $D_2 = 1$  cm, as shown in the figure. A part of the jet passes through the hole and the rest is deflected along the plate. The density of water is  $1000 \text{ kg m}^{-3}$ . If the speed of the jet is  $20 \text{ m s}^{-1}$ , the magnitude of the horizontal force, in N, required to hold the plate stationary is .

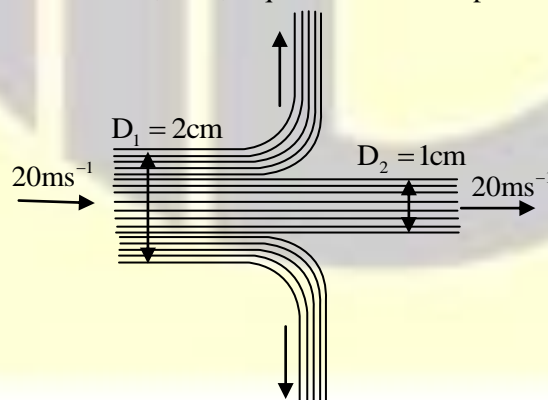

- (A)  $5\pi$  (A)  $20\pi$  (C)  $30\pi$  (D)  $10\pi$

**Answer: (C)**

[Click here to watch video explanation](#)

39. Consider a horizontal rod of radius  $aR$  ( $a < 1$ ) in a stationary pipe of radius  $R$ . The rod is pulled coaxially at a constant velocity  $V$  as shown in the figure. The annular region is filled with a Newtonian incompressible fluid of viscosity  $\mu$ . The steady state fully developed axial velocity profile in the fluid is given by  $u(r) = v \frac{\ln(r/R)}{\ln(a)}$ , where  $r$  is the radial coordinate. Ignoring end effects, the magnitude of the pulling force per unit rod length is

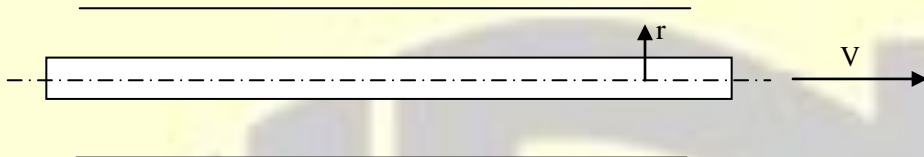

- (A)  $-\frac{2\pi\mu V}{\ln(a)}$       (B)  $\pi\mu V$       (C) 0      (D)  $-\frac{\pi\mu V}{\ln(a)}$

**Answer: (A)**

[Click here to watch video explanation](#)

40. Consider a bare long copper wire of 1mm diameter. Its surface temperature is  $T_s$  and the ambient temperature is  $T_a$  ( $T_s > T_a$ ). The wire is to be coated with a 2mm thick insulation. The convective heat transfer coefficient is  $20 \text{ W m}^{-2}\text{K}^{-1}$ . Assume that  $T_s$  and  $T_a$  remain unchanged. To reduce heat loss from the wire. The maximum allowed thermal conductivity of the insulating material. In  $\text{W m}^{-2}\text{K}^{-1}$ , rounded off to two decimal places, is

- (A) 0.04      (B) 0.02      (C) 0.10      (D) 0.01

**Answer: (B)**

[Click here to watch video explanation](#)

41. Two large parallel planar walls are maintained at 1000 K and 500 K. Parallel radiation shields are to be installed between the two walls. Assume that the emissivities of the walls and the shields are equal. If the melting temperature of the shields is 900 K, the maximum number of shield(s) that can be installed between the walls is (are)

- (A) 3      (B) 0      (C) 1      (D) 2

**Answer: (C)**

[Click here to watch video explanation](#)



42. Saturated steam condenses on a vertical plate maintained at a constant wall temperature. If  $x$  is the vertical distance from the top edge of the plate, then the local heat transfer coefficient  $h(x) \propto \Gamma(x)^{-1/3}$ , where  $\Gamma(x)$  is the local mass flow rate of the condensate per unit plate width. The ratio of the average heat transfer coefficient over the entire plate to the heat transfer coefficient at the bottom of the plate is  
 (A) 4 (B) 3/4 (C) 4/3 (D) 3

**Answer:** (C)

[Click here to watch video explanation](#)

43. Match the product in Group-1 with the manufacturing process in Group-2. The correct combination is

Group-1	Group-2
P. Nitric acid	1. Trona process
Q. Phosphoric acid	2. Twitchell process
R. Potassium chloride	3. Ostwald's process
S. Stearic acid	4. Haifa process

(A) P-III, Q-I, R-IV, S-II

(A) P-I, Q-IV, R-II, S-III

(C) P-III, Q-IV, R-I, S-II

(D) P-IV, Q-I, R-II, S-III

**Answer:** (C)

[Click here to watch video explanation](#)

44. The directional derivative of  $f(x, y, z) = 4x^2 + 2y^2 + z^2$  at the point (1,1,1) in the direction of the vector  $\vec{v} = \hat{i} - \hat{k}$  is \_\_\_\_\_ (rounded off to two decimal places)

**Answer:** (4.20 to 4.30)

[Click here to watch video explanation](#)

45. Consider a sphere of radius 4, centered at the origin, with outward unit normal  $\hat{n}$  on its surface  $S$ . The value of the surface integral  $\iint \left( \frac{2x\hat{i} + 3y\hat{j} + 4z\hat{k}}{4\pi} \right) \cdot \hat{n} dA$  is \_\_\_\_\_ (rounded off to one decimal place).

**Answer:** (19.19 to 192.1)

[Click here to watch video explanation](#)

46. The equation  $\frac{dy}{dx} = xy^2 + 2y + x - 4.5$  with the initial condition  $y(x=0)=1$  is to be solved using a predictor-corrector approach. Use a predictor based on the implicit Euler's method and a corrector based on the trapezoidal rule of integration, each with a full-step size of 0.5. Considering only positive values of  $y$ , the value of  $y$  at  $x=0.5$  is \_\_\_\_\_ (rounded off to three decimal places).

**Answer: (0.860 to 0.880)**

[Click here to watch video explanation](#)

47. A substance at  $4^\circ\text{C}$  has a thermal expansion coefficient  $\beta = \frac{1}{v} \left( \frac{\partial v}{\partial T} \right)_P = 0\text{K}^{-1}$ , an isothermal compressibility,  $K_T = -\frac{1}{v} \left( \frac{\partial v}{\partial P} \right)_T = 5 \times 10^{-4} \text{Pa}^{-1}$  and a molar volume  $v = 18 \times 10^{-6} \text{m}^3 \text{mol}^{-1}$ . If  $S$  is the molar entropy, then at  $4^\circ\text{C}$ , the quantity  $\left[ v \left( \frac{\partial s}{\partial v} \right)_T \right]$  evaluated for the substance is \_\_\_\_\_  $\text{J mol}^{-1} \text{K}^{-1}$  (rounded off to the nearest integer).

**Answer: (0 to 0)**

[Click here to watch video explanation](#)

48. The molar excess Gibbs free energy ( $g^E$ ) of a liquid mixture of A and B is given by

$$\frac{g^E}{RT} = x_A x_B [C_1 + C_2 (x_A - x_B)]$$

Where  $x_A$  and  $x_B$  are the mole fraction of A and B, respectively, the universal gas constant,  $R=8.314\text{JK}^{-1}$ ,  $T$  is the temperature in K, and  $C_1, C_2$  are temperature-dependent parameters. At 300K,  $C_1=0.45$  and  $C_2=-0.018$ . If  $\gamma_A$  and  $\gamma_B$  are the activity coefficients of A and B, respectively, the value of

$$\int_0^1 \ln \left( \frac{\gamma_A}{\gamma_B} \right) dx_A$$

at 300K and 1 bar is \_\_\_\_\_ (rounded off to the nearest integer)

**Answer: (0 to 0)**

[Click here to watch video explanation](#)

49. For a pure substance, the following data at saturated conditions are given:

$\ln P^{\text{sat}}$ (bar)	T (K)
0.693	350
1.386	370

Assume that the vapor phase behaves ideally. the molar volume of the liquid is negligible, and the latent heat of vaporization is constant over the given temperature range. The universal gas constant,  $R = 8.314 \text{ J K}^{-1} \text{ mol}^{-1}$ . From the above data, the estimated latent heat of vaporization at 360 K is \_\_\_\_\_ kJ/mol (rounded off to one decimal place).

**Answer:** (36.3 to 38.3)

[Click here to watch video explanation](#)

50. Consider the process flowsheet in the figure. An irreversible liquid-phase reaction  $A \rightarrow B$  (reaction rate  $-r_A = 164x_A \text{ kmol m}^{-3} \text{ h}^{-1}$ ) occurs in a  $1 \text{ m}^3$  continuous stirred tank reactor (CSTR), where  $x_A$  is the mole fraction of A. A small amount of inert, I, is added to the reactor. The reactor effluent is separated in a perfect splitter to recover pure B product down the bottoms and a B-free distillate. A fraction of the distillate is purged and the rest is recycled back to the reactor. At a particular steady state, the product rate is  $100 \text{ kmol h}^{-1}$ , the recycle rate is  $200 \text{ kmol h}^{-1}$  and the purge rate is  $10 \text{ kmol h}^{-1}$ . Given the above information, the inert feed rate into the process is \_\_\_\_\_  $\text{kmol h}^{-1}$  (rounded off to two decimal places).

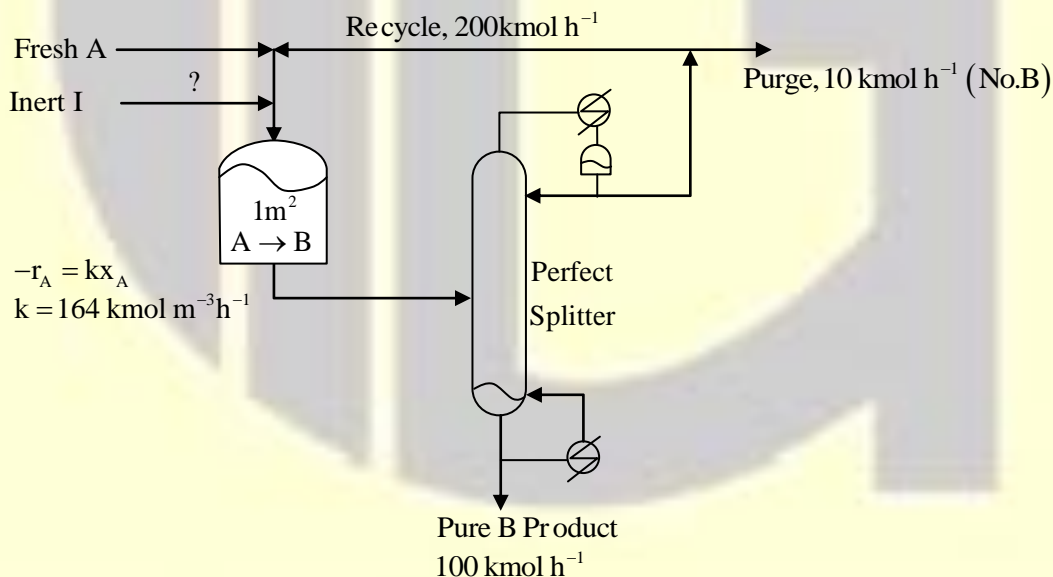

**Answer:** (0.95 to 1.05)

[Click here to watch video explanation](#)

51. Two reservoirs located at the same altitude are connected by a straight horizontal pipe of length 120m and inner diameter 0.5m, as shown in the figure. A pump transfers the liquid of density  $800\text{kg m}^{-3}$  at a flow rate of  $1\text{m}^3\text{s}^{-1}$  from Reservoir-1 to Reservoir-2. The liquid levels in Reservoir-1 and Reservoir-2 are 2m and 10m, respectively, Assume that the reservoirs' cross-section areas are large enough to neglect the liquid velocity at the top of the reservoirs. All minor losses can be ignored. The acceleration due to gravity is  $9.8\text{ms}^{-2}$ . If the friction factor for the pipe-flow is 0.01, the required power of the pump is \_\_\_\_\_ kW (rounded off to one decimal place).

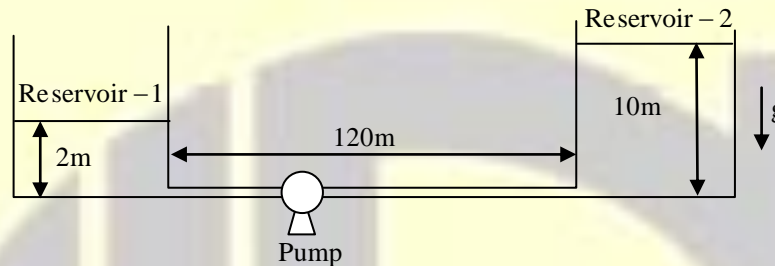

**Answer:** (161.7 to 163.2)

[Click here to watch video explanation](#)

52. A venturi meter (venturi coefficient,  $C_v = 0.98$ ) is connected to a pipe of inner diameter 50mm. Water (density  $1000\text{kg m}^{-3}$ ) is flowing through the pipe. The pressure-drop measured across the venturi meter is 50kPa. If the venturi throat diameter is 20mm, the estimated flow rate of water is \_\_\_\_\_  $\times 10^{-3}\text{m}^3\text{s}^{-1}$  (rounded off to two decimal places)

**Answer:** (3.10 to 3.17)

[Click here to watch video explanation](#)

53. In a constant-rate cake filtration operation, the collected filtrate volumes are  $120\text{ m}^3$  and  $240\text{ m}^3$  at 1 min and 2 min respectively. Assume the cake resistance to be constant and the filter medium resistance to be negligible. If the pressure-drop across the cake is 10 kPa at 1 min, its value at 2 min is \_\_\_\_\_ kPa (rounded off to the nearest integer).

**Answer:** (20 to 20)

[Click here to watch video explanation](#)

54. A cylindrical fin of 24mm is attached horizontally to a vertical planar wall. The heat transfer rate from the fin to the surrounding air is 60% of the heat transfer rate if the entire fin were at the wall temperature. If the fin effectiveness is 10. Its length is \_\_\_\_\_ mm (rounded off to the nearest integer).

**Answer:** (94 to 94)

[Click here to watch video explanation](#)

55. A single-effect evaporator with a heat transfer area of  $70\text{m}^2$  concentrates a salt solution using steam. The salt solution feed rate and temperature are  $10000\text{kg h}^{-1}$  and  $40^\circ\text{C}$  respectively. The saturated steam feed rate and temperature are  $7500\text{kg h}^{-1}$  and  $150^\circ\text{C}$ , respectively. The boiling temperature of the solution in the evaporator is  $80^\circ\text{C}$ . The average specific heat of the solution is  $0.8\text{kcal kg}^{-1}\text{K}^{-1}$ . The latent heat of vaporization is  $500\text{ kcal kg}^{-1}$ . If the steam economy is 0.8, the overall heat transfer coefficient is \_\_\_\_\_  $\text{kcal h}^{-1}\text{m}^2\text{K}^{-1}$  (rounded off to the nearest integer).

**Answer:** (675 to 680)

[Click here to watch video explanation](#)

56. An equimolar binary mixture is to be separated in a simple tray- distillation column. The feed rate is  $50\text{kmol min}^{-1}$ . The mole fractions of the more volatile component in the top and bottom products are 0.90 and 0.01, respectively. The feed as well as the reflux stream are saturated liquids, On application of the McCabe-Thiele method, the operating line for the stripping section is obtained as

$$Y=1.5x - 0.005$$

Where y and x are the mole fractions of the more volatile component in the vapor and liquid phases, respectively. The reflux ratio is \_\_\_\_\_ (rounded off to two decimal places).

**Answer:** (0.61 to 0.65)

[Click here to watch video explanation](#)

57. The dry-bulb temperature of air in a room is  $30^\circ\text{C}$ . The Antoine equation for water is given as

$$\ln P^{\text{sat}} = 12.00 - \frac{4000}{T - 40}$$

Where T is the temperature in K and  $P^{\text{sat}}$  is the saturation vapor pressure in bar. The latent heat of vaporization of water is  $2000\text{ kJ kg}^{-1}$ . The humid heat is  $1.0\text{ kJ kg}^{-1}, \text{K}^{-1}$ , and the molecular weights of air and water are  $28\text{kg kmol}^{-1}$  and  $18\text{ kg kmol}^{-1}$ , respectively. If the absolute humidity of air is Y' kg moisture per kg dry air, then for a wet-bulb depression of  $9^\circ\text{C}$ ,  $1000 \times Y' =$  \_\_\_\_\_ (rounded off to one decimal place).

**Answer:** (10.0 to 12.0)

[Click here to watch video explanation](#)

58. In the block diagram shown in the figure, the transfer function  $G = \frac{K}{(\tau s + 1)}$  with  $K > 0$  and  $\tau > 0$ . The maximum value of  $K$  below which the system remains stable is \_\_\_\_\_ (rounded off two decimal places).

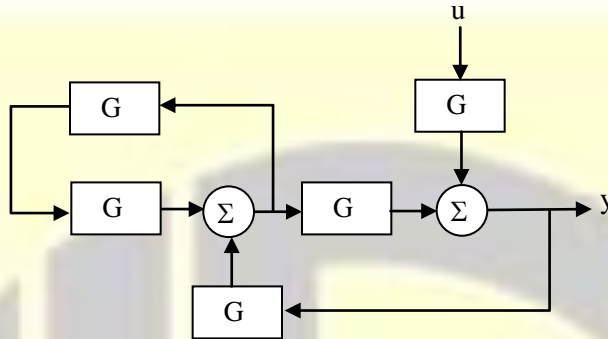

**Answer:** (0.70 to 0.72)

[Click here to watch video explanation](#)

59. Consider the tank level control system shown in the figure, where the cross-section area of the tank is  $A$ . Assume perfect flow controllers (F(C)). The level controller (L(C)) is proportional-integral (PI). For an integral time,  $\tau_i$ , the level controller gain,  $K_c$  is tuned for critical damping. The value of  $\frac{K_c \tau_i}{A}$  is \_\_\_\_\_ (rounded off to the nearest integer).

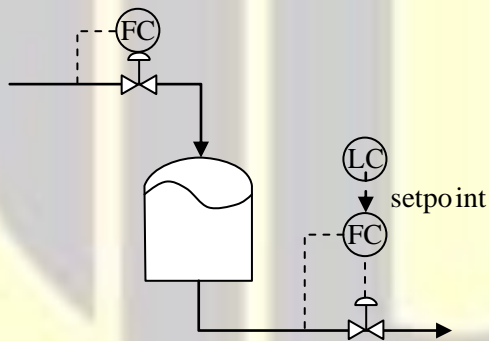

**Answer:** (-4 or 4)

[Click here to watch video explanation](#)

60. Consider a single-input-single – output (SISO) System with the transfer function

$$G_p(s) = \frac{2(s+1)}{\left(\frac{1}{2}s+1\right)\left(\frac{1}{4}s+1\right)}$$

Where the time constants are in minutes. The system is forced by a unit step input at time  $t=0$ . The time at which the output response reaches the maximum is \_\_\_\_\_ minutes (rounded of two decimal places).

**Answer: (0.54 to 0.56)**

[Click here to watch video explanation](#)

61. Information for a proposed greenfield project is provided in the table. The discounted cash flow for the fourth year is Rs. \_\_\_\_\_ crores (rounded off to one decimal place)

Fixed capital investment (excluding lan(D)	Rs 250 crores
Salvage value	Rs 0
Yearly revenue from product sales	Rs 120 crores
Yearly manufacturing cost (excluding depreciation)	Rs 30 crores
Interest rate	10% compounded annually
Annual taxation rate	30 %
Depreciation method	Double declining balance*
	Over seven years
Plant start – up	2 years after project initiation

\* $d_k = \frac{2}{7} BV_{k-1}$  k: years post start-up d: Depreciation amount BV: Book value.

**Answer: (52.0 to 54.0)**

[Click here to watch video explanation](#)

62. Consider the process flowsheet in the figure. An irreversible liquid-phase reaction  $A \rightarrow B$  (reaction rate  $-r_A = 164x_A \text{ kmol m}^{-3} \text{ h}^{-1}$ ) occurs in a  $1 \text{ m}^3$  continuous stirred tank reactor (CSTR), where  $x_A$  is the mole fraction of A. A small amount of inert, I, is added to the reactor. The reactor effluent is separated in a perfect splitter to recover pure B product down the bottoms and a B-free distillate. A fraction of the distillate is purged and the rest is recycled back to the reactor. At a particular steady state, the product rate is  $100 \text{ kmol h}^{-1}$ , the recycle rate is  $200 \text{ kmol h}^{-1}$  and the purge rate is  $10 \text{ kmol h}^{-1}$ . Given the above information, the inert feed rate into the process is \_\_\_\_\_  $\text{kmol h}^{-1}$  (rounded off to two decimal places).

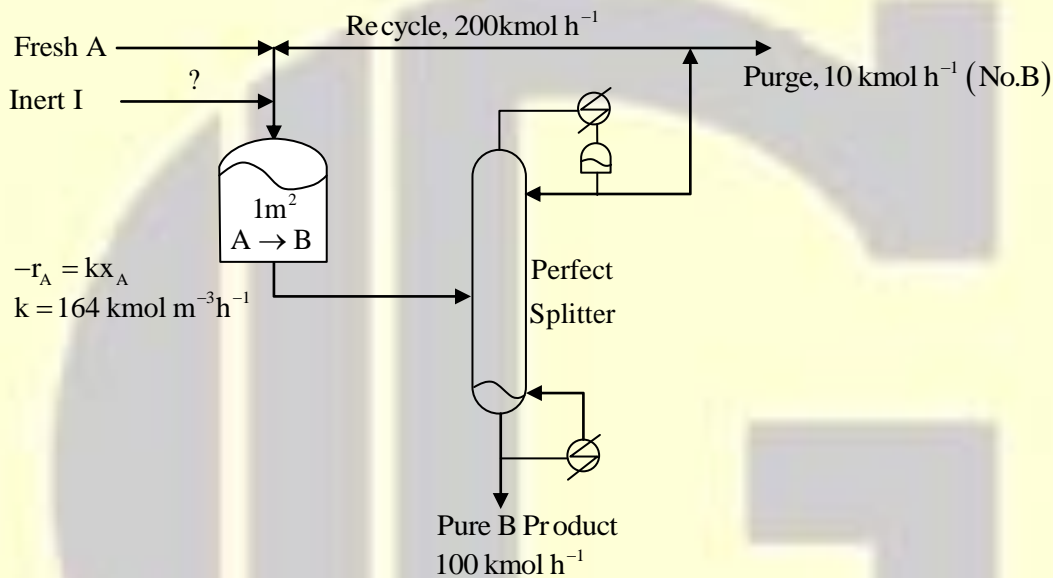

**Answer: (3 to 3)**

[Click here to watch video explanation](#)

63. An elementary irreversible liquid-phase reaction,  $2A \rightarrow B$ , is carried out under isothermal conditions in a  $1 \text{ m}^3$  ideal plug flow reactor (PFR) as shown in the figure. The volumetric flow rate of fresh A,  $v_1 = 10 \text{ m}^3 \text{ h}^{-1}$ , and its concentration  $C_{A1} = 2 \text{ kmol m}^{-3}$ . For a recycle ratio  $R = 0$ , the conversion of A at location 2 with respect to the fresh feed (location 1) is 50%. For  $R \rightarrow \infty$ , the corresponding conversion of A is \_\_\_\_\_ % (rounded off to one decimal place).

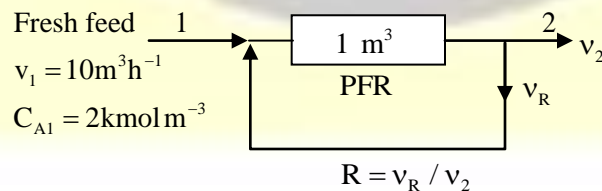

**Answer: (38.0 to 38.5)**

[Click here to watch video explanation](#)



64. An elementary irreversible gas-phase reaction,  $A \rightarrow B + C$ , is carried out at fixed temperature and pressure in two separate ideal reactors: (i) a  $10\text{m}^3$  plug flow reactor (PFR), (ii) a  $10\text{m}^3$  continuous-stirred tank reactor (CSTR). If pure A is fed at  $5\text{m}^3\text{h}^{-1}$  to the PFR operating at  $400\text{K}$ , the conversion is  $80\%$ . If a mixture of  $50\text{mol}\%$  of A and  $50\text{mol}\%$  of an inert is fed at  $5\text{m}^3\text{h}^{-1}$  to the CSTR operating at  $425\text{K}$ , the conversion is  $80\%$ . The universal gas constant  $R=8.34\text{J mol}^{-1}\text{K}^{-1}$ . Assuming the Arrhenius rate law, the estimated activation energy is \_\_\_\_\_  $\text{kJ mol}^{-1}$  (rounded off to one decimal place).

**Answer:** (47.0 to 49.0)

[Click here to watch video explanation](#)

65. An elementary irreversible liquid-phase reaction,  $2P \xrightarrow{k} Q$ , where the rate constant  $k=2\text{L mol}^{-1}\text{min}^{-1}$ , takes place in an isothermal non-ideal reactor. The E-curve in a tracer experiment is shown in the figure. Pure P ( $2\text{mol L}^{-1}$ ) is fed to the reactor. Using the segregated model. The percentage conversion of P at the exit of the reactor is \_\_\_\_\_ % (rounded off to the nearest integer).

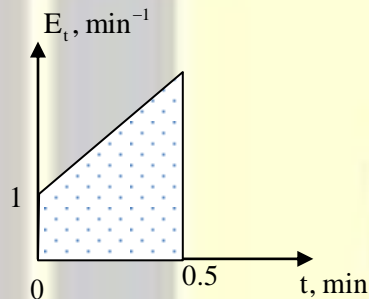

**Answer:** (50 to 50)

[Click here to watch video explanation](#)





Follow us @



For more details visit [gateforumonline.com](http://gateforumonline.com)