

GENERAL APTITUDE**Q. No. 1 -5 Carry One Mark Each**

1. Inhaling the smoke from a burning _____ could _____ you quickly.
(A) tire / tier (B) tire / tyre (C) tyre / tire (D) tyre / tier

Answer: (C) [Click here to watch video explanation](#)

2. A sphere of radius r cm is packed in a box of cubical shape.
What should be the minimum volume (in cm^3) of the box that can enclose the sphere?
(A) $\frac{r^3}{8}$ (B) r^3 (C) $2r^3$ (D) $8r^3$

Answer: (D) [Click here to watch video explanation](#)

3. Pipes P and Q can fill a storage tank in full with water in 10 and 6 minutes, respectively. Pipe R draws the water out from the storage tank at a rate of 34 litres per minute. P, Q and R operate at a constant rate. If it takes one hour to completely empty a full storage tank with all the pipes operating simultaneously, what is the capacity of the storage tank (in litres)?
(A) 26.8 (B) 60.0 (C) 120.0 (D) 127.5

Answer: (C) [Click here to watch video explanation](#)

4. Six persons P, Q, R, S, T and U are sitting around a circular table facing the center not necessarily in the same order. Consider the following statements:
- P sits next to S and T.
 - Q sits diametrically opposite to P.
 - The shortest distance between S and R is equal to the shortest distance between T and U.
- Based on the above statements, Q is a neighbor of
(A) U and S (B) R and T (C) R and U (D) P and S

Answer: (C) [Click here to watch video explanation](#)

5. A building has several rooms and doors as shown in the top view of the building given below. The doors are closed initially.

What is the minimum number of doors that need to be opened in order to go from the point P to the point Q?

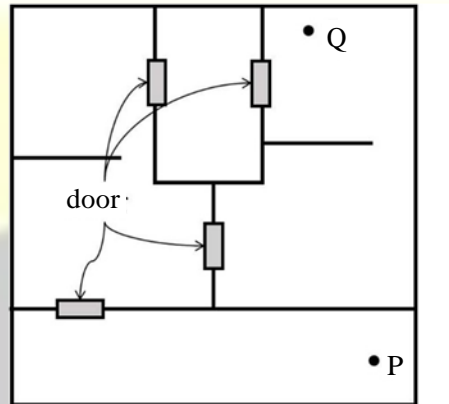

- (A) 4 (B) 3 (C) 2 (D) 1

Answer: (C)

[Click here to watch video explanation](#)

Q. No. 6 -10 Carry Two Marks Each

6. Rice, a versatile and inexpensive source of carbohydrate, is a critical component of diet worldwide. Climate change, causing extreme weather, poses a threat to sustained availability of rice. Scientists are working on developing Green Super Rice (GSR), which is resilient under extreme weather conditions yet gives higher yields sustainably.

Which one of the following is the CORRECT logical inference based on the information given in the above passage?

- (A) GSR is an alternative to regular rice, but it grows only in an extreme weather
(B) GSR may be used in future in response to adverse effects of climate change
(C) GSR grows in an extreme weather, but the quantity of produce is lesser than regular rice
(D) Regular rice will continue to provide good yields even in extreme weather

Answer: (B)

[Click here to watch video explanation](#)

7. A game consists of spinning an arrow around a stationary disk as shown below. When the arrow comes to rest, there are eight equally likely outcomes. It could come to rest in any one of the sectors numbered 1, 2, 3, 4, 5, 6, 7 or 8 as shown. Two such disks are used in a game where their arrows are independently spun. What is the probability that the sum of the numbers on the resulting sectors upon spinning the two disks is equal to 8 after the arrows come to rest?

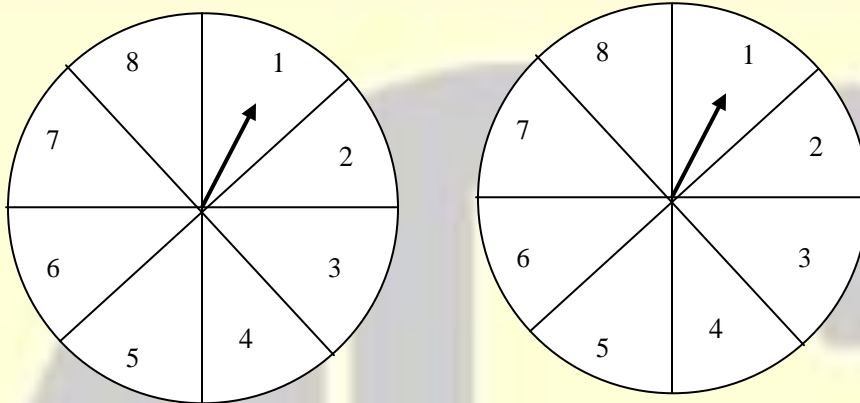

- (A) $\frac{1}{16}$ (B) $\frac{5}{64}$ (C) $\frac{3}{32}$ (D) $\frac{7}{64}$

Answer: (D)

[Click here to watch video explanation](#)

8. Consider the following inequalities.

(i) $3p - q < 4$

(ii) $3q - p < 12$

Which one of the following expressions below satisfies the above two inequalities?

- (A) $p + q < 8$ (B) $p + q = 8$ (C) $8 \leq p + q < 16$ (D) $p + q \geq 16$

Answer: (A)

[Click here to watch video explanation](#)

9. Given below are three statements and four conclusions drawn based on the statements.

Statement 1: Some engineers are writers.

Statement 2: No writer is an actor.

Statement 3: All actors are engineers.

Conclusion I: Some writers are engineers.

Conclusion II: All engineers are actors.

Conclusion III: No actor is a writer.

Conclusion IV: Some actors are writers.

Which one of the following options can be logically inferred?

- (A) Only conclusion I is correct
- (B) Only conclusion II and conclusion III are correct
- (C) Only conclusion I and conclusion III are correct
- (D) Either conclusion III or conclusion IV is correct

Answer: (C)

[Click here to watch video explanation](#)

10. Which one of the following sets of pieces can be assembled to form a square with a single round hole near the center? Pieces cannot overlap.

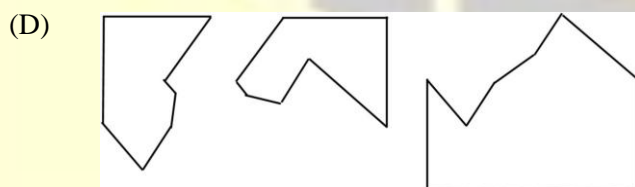
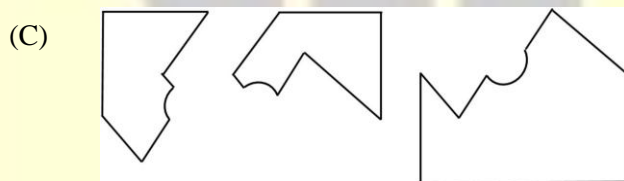
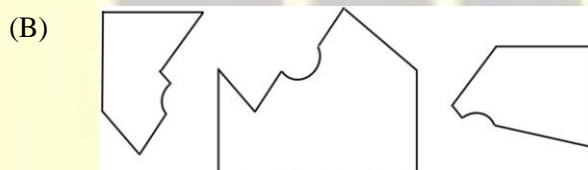
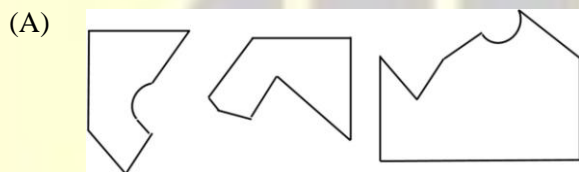

Answer: (C)

[Click here to watch video explanation](#)

INSTRUMENTATION ENGINEERING

Q. No. 11-35 Carry One Mark Each

11. The input (t) to a system is related to its output (t) as $\frac{dy(t)}{dt} + y(t) = 3x(t-3)u(t-3)$ Here $u(t)$ Here $u(t)$ represents a unit-step function. The transfer function of this system is _____
- (A) $\frac{e^{-3s}}{s+3}$ (B) $\frac{3e^{-3s}}{s+1}$ (C) $\frac{3e^{-(s/3)}}{s+1}$ (D) $\frac{e^{-(s/3)}}{s+3}$

Answer: (B) [Click here to watch video explanation](#)

12. A pneumatic nozzle-flapper system is conventionally used to convert _____
- (A) Small changes in flapper's velocity to large changes in output temperature
 (B) Small changes in flapper's displacement to large changes in output temperature
 (C) Small changes in flapper's displacement to large changes in output pressure
 (D) Small changes in flapper's displacement to large changes in output pressure

Answer: (D) [Click here to watch video explanation](#)

13. A periodic function (x) , with period 2, is defined as $f(x) = \begin{cases} -1-x & -1 \leq x < 0 \\ 1-x & 0 < x \leq 1 \end{cases}$ The Fourier series of this function contains _____
- (A) Both $\cos(n\pi x)$ and $\sin(n\pi x)$ where $n = 1, 2, 3, \dots$
 (B) Only $\sin(n\pi x)$ where $n = 1, 2, 3, \dots$
 (C) Only $\cos(n\pi x)$ where $n = 1, 2, 3, \dots$
 (D) Only $\cos(2n\pi x)$ where $n = 1, 2, 3, \dots$

Answer: (B) [Click here to watch video explanation](#)

14. The output of a system (t) is related to its input (t) according to the relation $(t) = x(t) \sin(2\pi t)$. This system is _____
- (A) Linear and time-variant (B) Non-linear and time-invariant
 (C) Linear and time-invariant (D) Non-linear and time-variant

Answer: (A) [Click here to watch video explanation](#)

15. A unity-gain negative-feedback control system has a loop-gain (s) given by $L(s) = \frac{6}{s(s-5)}$

The closed-loop system is _____

- (A) Causal and stable (B) Causal and unstable
(C) Non-causal and stable (D) Non-causal and unstable

Answer: (B)

[Click here to watch video explanation](#)

16. A sinusoidal carrier wave with amplitude A_c and frequency f_c amplitude modulated with a message signal (t) having frequency $0 < f_m \ll f_c$ to generate the modulated wave (t) given by

$$s(t) = A_c [1 + m(t)] \cos(2\pi f_c t)$$

The message signal that can be retrieved completely using envelope detection is _____

- (A) $m(t) = 0.5 \cos(2\pi f_m t)$ (B) $m(t) = 1.5 \sin(2\pi f_m t)$
(C) $m(t) = 2 \sin(4\pi f_m t)$ (D) $m(t) = 2 \cos(4\pi f_m t)$

Answer: (A)

[Click here to watch video explanation](#)

17. A Hall sensor is based on the principle of _____

- (A) Photoelectric effect (B) Seebeck effect
(C) Piezoelectric effect (D) Lorentz force

Answer: (D)

[Click here to watch video explanation](#)

18. A signal (t) is band-limited between 100 Hz and 200 Hz. A signal (t) is related to (t) as follows: $(t) = x(2t - 5)$. The statement that is always true is _____

- (A) $y(t)$ is band-limited between 50 Hz and 100 Hz
(B) $y(t)$ is band-limited between 100 Hz and 200 Hz
(C) $y(t)$ is band-limited between 200 Hz and 400 Hz
(D) (t) is not band-limited

Answer: (C)

[Click here to watch video explanation](#)

19. The figure shows a Chromel-Alumel thermocouple, where the junction A is held at temperature T_A , and a thermal emf E_1 is measured using an ideal voltmeter between the open ends B1 and B2, both held at temperature T_B . Two identical copper wires are introduced between B1-C1 and B2-C2 as shown in the figure. When C1 and C2 are held at temperature T_C , the voltmeter reads a thermal emf E_2 . Then,

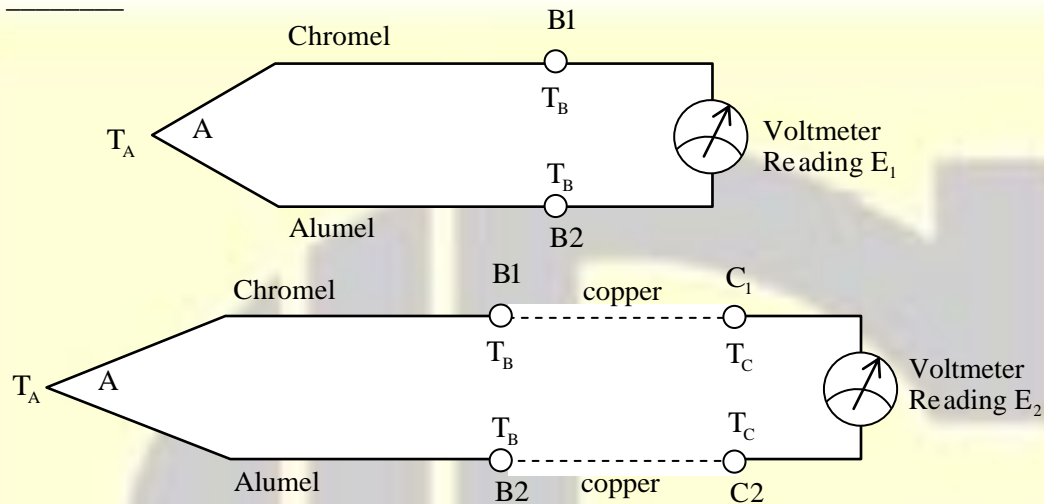

- (A) $E_1 < E_2$ (B) $E_1 > E_2$ (C) $E_1 = 2E_2$ (D) $E_1 = E_2$

Answer: (D)

[Click here to watch video explanation](#)

20. The resistance of a pure copper wire of length 10 cm and diameter 1 mm is to be measured. The most suitable method from amongst the choices given below is _____

- (A) Two wire method (B) Three wire method
(C) Four wire method (D) Ellipsometry

Answer: (C)

[Click here to watch video explanation](#)

21. The logic block shown has an output F given by _____

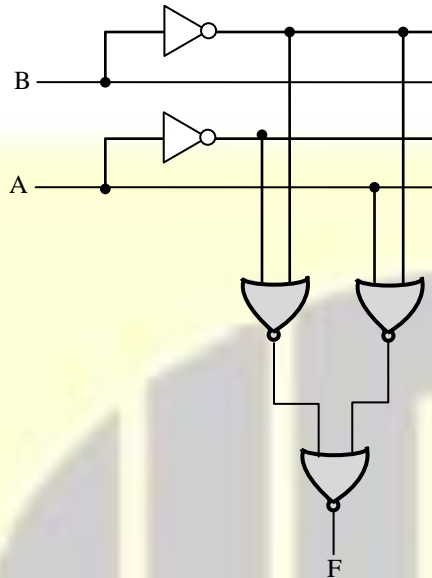

- (A) $A + B$ (B) $A \cdot \bar{B}$ (C) $A + \bar{B}$ (D) \bar{B}

Answer: (C)

[Click here to watch video explanation](#)

22. In which of the following bridge(s) is the balancing condition frequency-independent?

- (A) Maxwell bridge (B) Wien bridge
(C) Schering bridge (D) Wheatstone bridge

Answer: (A, C, D)

[Click here to watch video explanation](#)

23. The output F of the digital circuit shown can be written in the form(s) _____

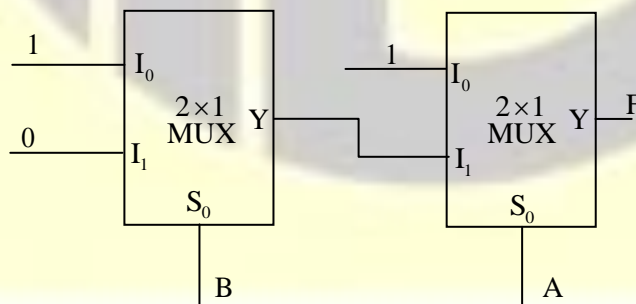

- (A) $\overline{A \cdot B}$ (B) $\bar{A} + \bar{B}$ (C) $\overline{A + B}$ (D) $\bar{A} \cdot \bar{B}$

Answer: (A, B)

[Click here to watch video explanation](#)

24. Given $M = \begin{bmatrix} 2 & 3 & 7 \\ 6 & 4 & 7 \\ 4 & 6 & 14 \end{bmatrix}$, which of the following statement(s) is/are correct?

- (A) The rank of M is 2
(B) The rank of M is 3
(C) The rows of M are linearly independent
(D) The determinant of M is 0

Answer: (A, D)

[Click here to watch video explanation](#)

25. An analog-to-digital converter with resolution 0.01 V converts analog signals between 0 V to +10 V to an unsigned binary output. The minimum number of bits (in integer) in the output is _____

Answer: (10 to 10)

[Click here to watch video explanation](#)

26. Consider 24 voice signals being transmitted without latency using time-division multiplexing. If each signal is sampled at 12 kHz and represented by an 8-bit word, the bit-duration (in microseconds) is _____ (round off to two decimal places)

Answer: (0.42 to 0.44)

[Click here to watch video explanation](#)

27. A photodiode is made of a semiconductor with a bandgap of 1.42 eV. Given that Planck's constant is 6.626×10^{-34} Js, the speed of light in vacuum is 3×10^8 m/s, and $1 \text{ eV} = 1.6 \times 10^{-19}$ J, the cut-off wavelength (in nanometers) of the photodiode is _____ (round off to one decimal place)

Answer: (870.0 to 880.0)

[Click here to watch video explanation](#)

28. The global minimum of $x^3 e^{-|x|}$ for $x \in (-\infty, \infty)$ occurs at $x =$ _____ (round off to one decimal place)

Answer: (-3.0 to -3.0)

[Click here to watch video explanation](#)

29. A 440 V, 8 kW, 4-pole, 50 Hz, star-connected induction motor has a full load slip of 0.04. The rotor speed (in rpm) at full load is _____ (round off to one decimal place)

Answer: (1440.0 to 1440.0)

[Click here to watch video explanation](#)

30. The transfer function of a system is: $\frac{(s+1)(s+3)}{(s+5)(s+7)(s+9)}$

In the state-space representation of the system, the minimum number of state variables (in integer) necessary is _____

Answer: (3 to 3)

[Click here to watch video explanation](#)

31. A Zener diode is used as a 4 V voltage regulator in the circuit shown. Given that the diode requires a minimum current of 4 mA for voltage regulation, the maximum current (in milliamperes) permitted to flow through the load R_L is _____ (round off to one decimal place)

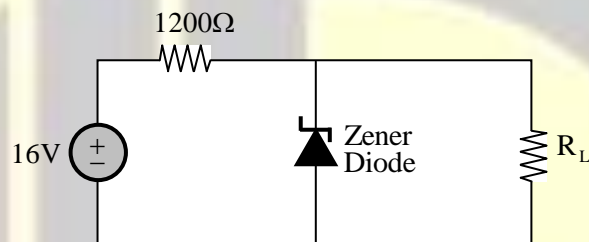

Answer: (6.0 to 6.0)

[Click here to watch video explanation](#)

32. A bag contains six red balls and four blue balls. If three balls are drawn in succession without replacement, the probability that the second and third balls drawn are red is _____ (round off to two decimal places)

Answer: (0.32 to 0.34)

[Click here to watch video explanation](#)

33. In the bandpass filter circuit shown, $R_0 = 50\Omega$, $L_0 = 1\text{mH}$, $C_0 = 10\text{nF}$. The Q factor of the filter is _____ (round off to two decimal places)

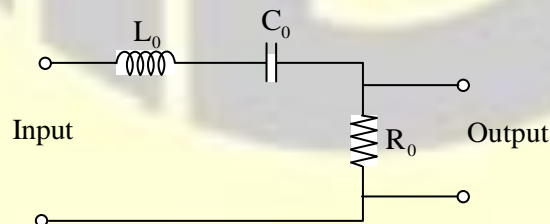

Answer: (6.22 to 6.42)

[Click here to watch video explanation](#)

34. The Newton-Raphson method is applied to determine the solution of $f(x)=0$ where $f(x) = x - \cos(x)$. If the initial guess of the solution is $x_0 = 0$, the value of the next approximation x_1 is _____ (round off to two decimal places).

Answer: (0.99 to 1.01)

[Click here to watch video explanation](#)

35. An OPAMP has a gain of 10^4 , an input impedance of $10\text{ M}\Omega$ and an output impedance of $100\ \Omega$. The OPAMP is used in unity-gain feedback configuration in a voltage buffer circuit. The closed-loop output impedance of the OPAMP (in milliohms) in the circuit is _____ (round off to one decimal place)

Answer: (9.9 to 10.0)

[Click here to watch video explanation](#)

Q. No. 36 -65 Carry Two Marks Each

36. A signal $V_{in}(t)$ shown is applied from $t = 0\text{ ms}$ to $t = 6\text{ ms}$ to the circuit shown. Given the initial voltage across the capacitor is 0.3 V , and that the diode is ideal, the open circuit voltage $V_{out}(t)$ at $t = 5\text{ ms}$ is

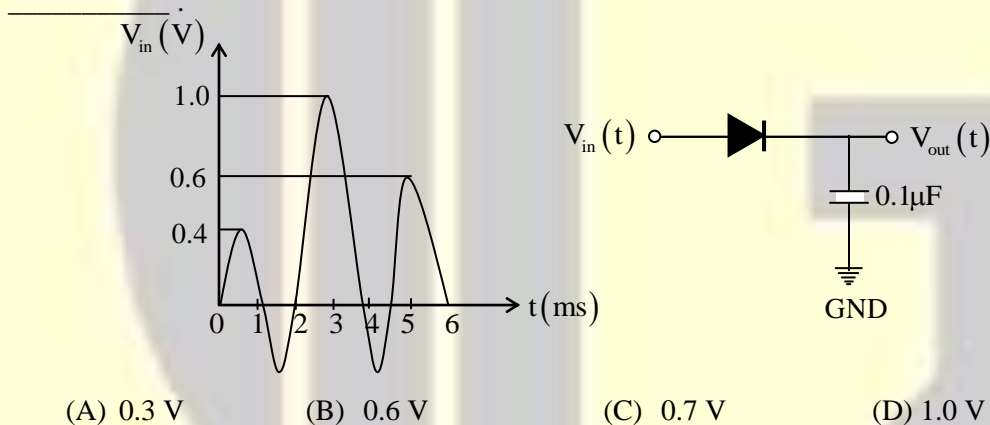

Answer: (D)

[Click here to watch video explanation](#)

37. The signal flow graph of a system is shown. The expression for $Y(s)/X(s)$ is _____

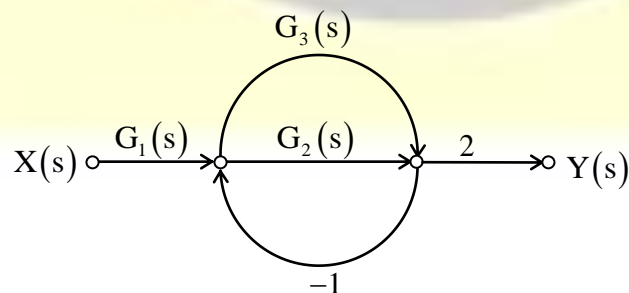

- (A) $\frac{2G_1(s)G_2(s)+2G_1(s)G_3(s)}{1+G_2(s)+G_3(s)}$ (B) $2+G_1(s)+G_3(s)+\frac{G_2(s)}{1+G_2(s)}$
- (C) $G_1(s)+G_3(s)-\frac{G_2(s)}{2+G_2(s)}$ (D) $\frac{2G_1(s)G_2(s)+2G_1(s)G_3(s)-G_1(s)}{1+G_2(s)+G_3(s)}$

Answer: (A)

[Click here to watch video explanation](#)

38. Consider the transfer function $H_c(s) = \frac{1}{(s+1)(s+3)}$. Bilinear transformation with a sampling period of 0.1 s is employed to obtain the discrete-time transfer function $H_d(z)$. Then $H_d(z)$ is _____

- (A) $\frac{(1+z^{-1})^2}{(19-21z^{-1})(23-17z^{-1})}$ (B) $\frac{(1-z^{-1})^2}{(21-19z^{-1})(17-23z^{-1})}$
- (C) $\frac{(1-z^{-1})^2}{(21-19z^{-1})(23-17z^{-1})}$ (D) $\frac{(1+z^{-1})^2}{(21-19z^{-1})(17-23z^{-1})}$

Answer: (C)

[Click here to watch video explanation](#)

39. A car is moving collinearly with a laser beam emitted by a transceiver. A laser pulse emitted at $t = 0$ s is received back by the transceiver 100 ns (nanoseconds) later after reflection from the car. A second pulse emitted at $t = 0.1$ s is received back 90 ns later. Given the speed of light is 3×10^8 m/s, the average speed of the car in this interval is _____

- (A) 54 kmph, moving towards the transceiver
 (B) 108 kmph, moving towards the transceiver
 (C) 54 kmph, moving away from the transceiver
 (D) 108 kmph, moving away from the transceiver

Answer: (A)

[Click here to watch video explanation](#)

40. The signal $x(t) = (t-1)^2 u(t-1)$, where $u(t)$ is the unit-step function, has the Laplace transform $X(s)$. The value of $X(1)$ is _____

- (A) $\frac{1}{e}$ (B) $\frac{2}{e}$ (C) $2e$ (D) e^2

Answer: (B)

[Click here to watch video explanation](#)

41. A proportional-integral-derivative (PID) controller is employed to stably control a plant with transfer function $P(s) = \frac{1}{(s+1)(s+2)}$

Now, the proportional gain is increased by a factor of 2, the integral gain is increased by a factor of 3, and the derivative gain is left unchanged. Given that the closed-loop system continues to remain stable with the new gains, the steady-state error in tracking a ramp reference signal _____

- (A) Remains unchanged (B) Decreases by a factor of 2
(C) Decreases by a factor of 3 (D) Decreases by a factor of 5

Answer: (C)

[Click here to watch video explanation](#)

42. A resistor ladder digital-to-analog converter (DAC) receives a digital input that results in the circuit having the state as shown in the figure. For this digital input, the Thevenin voltage, V_{th} , and Thevenin resistance, R_{th} , as seen at the output node are _____

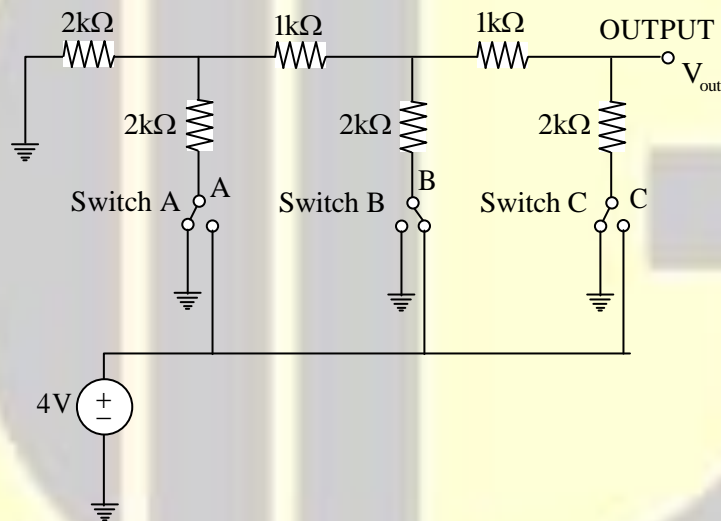

- (A) $V_{th} = 0.5\text{ V}, R_{th} = 1\text{ k}\Omega$ (B) $V_{th} = 0.5\text{ V}, R_{th} = 2\text{ k}\Omega$
(C) $V_{th} = 1\text{ V}, R_{th} = 1\text{ k}\Omega$ (D) $V_{th} = 1\text{ V}, R_{th} = 2\text{ k}\Omega$

Answer: (C)

[Click here to watch video explanation](#)

43. The Nyquist plot of a stable open-loop system $G(j\omega)$ is plotted in the frequency range $0 \leq \omega < \infty$ as shown. It is found to intersect a unit circle with center at the origin at the point $P = -0.77 - 0.64j$. The points Q and R lie on $G(j\omega)$ and assume values $Q = 14.40 + 0.00j$ and $R = -0.21 + 0.00j$. The phase margin (PM) and the gain margin (GM) of the system are _____

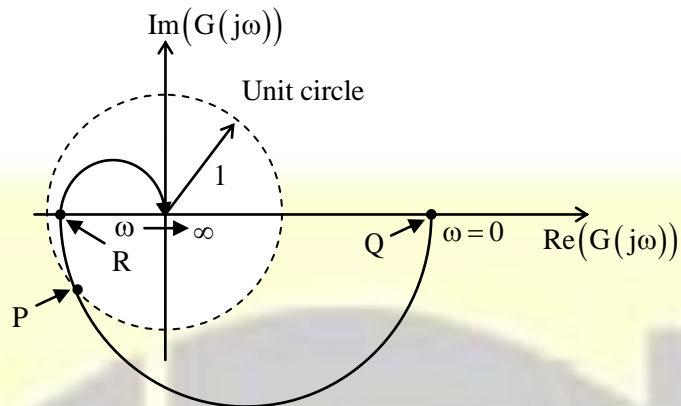

- (A) $PM = 39.7^\circ$ and $GM = 4.76$ (B) $PM = 39.7^\circ$ and $GM = 0.07$
 (C) $PM = -39.7^\circ$ and $GM = 4.76$ (D) $PM = -39.7^\circ$ and $GM = 0.07$

Answer: (A)

[Click here to watch video explanation](#)

44. In the small signal circuit shown, the enhancement mode n-channel MOSFET is biased in saturation with transconductance g_m . If channel length modulation is ignored, the small signal impedance looking into the node P is given by _____

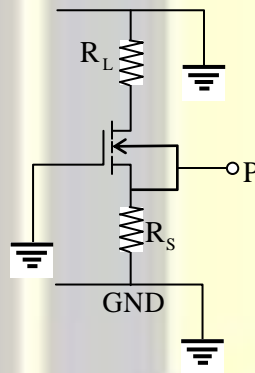

- (A) $R_S \parallel R_L \parallel g_m^{-1}$ (B) $R_S \parallel g_m^{-1}$
 (C) $(R_S + R_L) \parallel g_m^{-1}$ (D) $\frac{R_L g_m}{1 + R_S g_m} (R_L \parallel g_m^{-1})$

Answer: (B)

[Click here to watch video explanation](#)

45. Consider the differential equation $\frac{dy}{dx} + y \ln(y) = 0$ If $y(0) = e$, then $y(1)$ is _____

- (A) e^e (B) e^{-e} (C) $e^{(1/e)}$ (D) $e^{(-1/e)}$

Answer: (C)

[Click here to watch video explanation](#)

46. The digital circuit shown _____

- (A) is a divide-by-5 counter
(B) is a divide-by-7 counter
(C) is a divide-by-8 counter

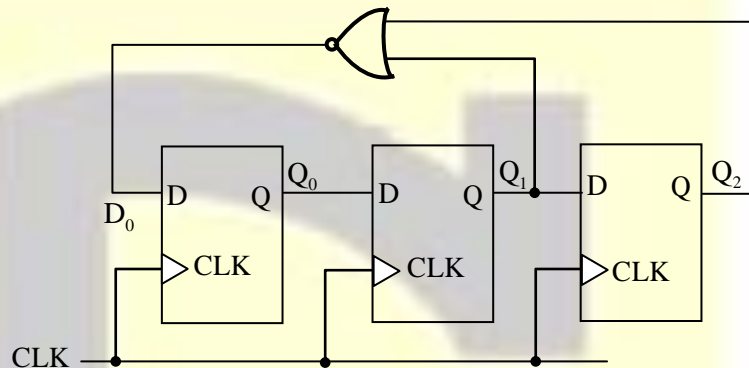

- (D) does not function as a counter due to disjoint cycles of states

Answer: (A)

[Click here to watch video explanation](#)

47. In the small signal circuit shown, the enhancement mode n-channel MOSFET is biased in saturation with a transconductance g_m . A small signal low-frequency voltage v_d injected at the supply terminal results in a small signal voltage fluctuation v_o at the output. If the channel length modulation of the MOSFET is ignored, the small signal gain v_o / v_d is given by _____

- (A) $\frac{-g_m R_0}{1 + g_m R_0}$
(B) $(g_m R_0 + 1)^{-1}$
(C) $\frac{-g_m R_0}{1 + 2g_m R_0}$
(D) $\left(\frac{g_m R_0}{2} + \frac{3}{2}\right)^{-1}$

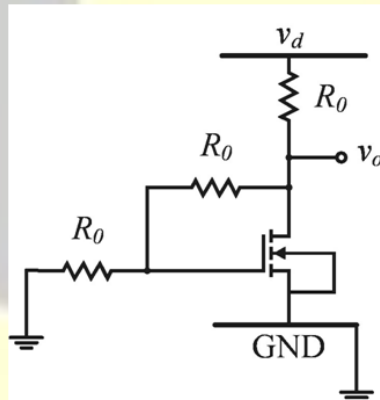

Answer: (D)

[Click here to watch video explanation](#)

48. $A = a_1a_0$ and $B = b_1b_0$ are two 2-bit unsigned binary numbers. If $F(a_1, a_0, b_1, b_0)$ is a Boolean function such that $F=1$ only when $A > B$, and $F=0$ otherwise, then F can be minimized to the form _____
- (A) $a_1\bar{b}_1 + a_1a_0\bar{b}_0$ (B) $a_1\bar{b}_1 + a_1a_0\bar{b}_0 + a_0\bar{b}_0\bar{b}_1$
 (C) $a_1a_0\bar{b}_0 + a_0\bar{b}_0\bar{b}_1$ (D) $a_1\bar{b}_1 + a_1a_0\bar{b}_0 + a_0\bar{b}_0b_1$

Answer: (B)

[Click here to watch video explanation](#)

49. The matrix $A = \begin{bmatrix} 4 & 3 \\ 9 & -2 \end{bmatrix}$ has eigen values -5 and 7 . The eigenvector(s) is/are _____
- (A) $\begin{bmatrix} 1 \\ 1 \end{bmatrix}$ (B) $\begin{bmatrix} 3 \\ 4 \end{bmatrix}$ (C) $\begin{bmatrix} 2 \\ -6 \end{bmatrix}$ (D) $\begin{bmatrix} 2 \\ 8 \end{bmatrix}$

Answer: (A,C)

[Click here to watch video explanation](#)

50. For the complex number $Z = \frac{a + jb}{a - jb}$, Where $a > 0$ and $b > 0$. Which of the following statement(s) is/are true?
- (A) The phase is $2 \tan^{-1} \frac{b}{a}$ (B) The phase is $\tan^{-1} \frac{2b}{a}$
 (C) The magnitude is 1 (D) The magnitude is $\sqrt{\frac{a^2 + b^2}{a^2 - b^2}}$

Answer: (A,C)

[Click here to watch video explanation](#)

51. Monochromatic light of wavelength 532 nm is used to measure the absorption coefficient of a material in a UV-Visible Spectrophotometer. The measured light intensity after transmission through a 1cm thick sample of the material is 0.414 mW/cm². For a sample of thickness 2cm, the measured light intensity is 0.186 mW/cm². The absorption coefficient (in cm⁻¹) of the material is _____ (round off to two decimal places)

Answer: (0.75 to 0.85)

[Click here to watch video explanation](#)

52. In the circuit shown, the load is driven by a sinusoidal ac voltage source $V_1 = 100\angle 0^\circ\text{V}$ at Hz. Given $R_1 = 20\Omega$, $C_1 = \left(\frac{1000}{\pi}\right)\mu\text{F}$, $L_1 = \left(\frac{20}{\pi}\right)\text{mH}$ and $R_2 = 4\Omega$, the power factor is _____ (round off to one decimal place)

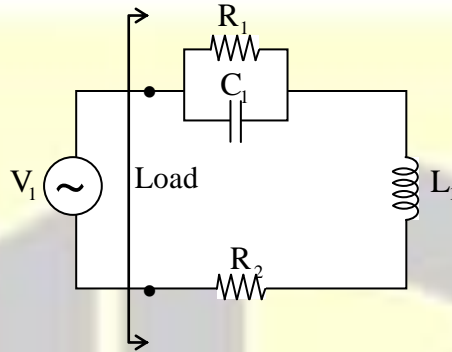

Answer: (0.8 to 0.8)

[Click here to watch video explanation](#)

53. In a unity-gain feedback control system, the plant $P(s) = \frac{0.001}{s(2s+1)(0.01s+1)}$ is controlled by a lag

$$\text{compensator } C(s) = \frac{s+10}{s+0.1}$$

The slope (in dB/decade) of the asymptotic Bode magnitude plot of the loop gain at $\omega = 3 \text{ rad/s}$ is _____ (in integer)

Answer: (-60 to -60)

[Click here to watch video explanation](#)

54. Given Circuit A with currents I_1 and I_2 as shown, the current I_3 in Circuit B (in amperes), is _____ (round off to one decimal place)

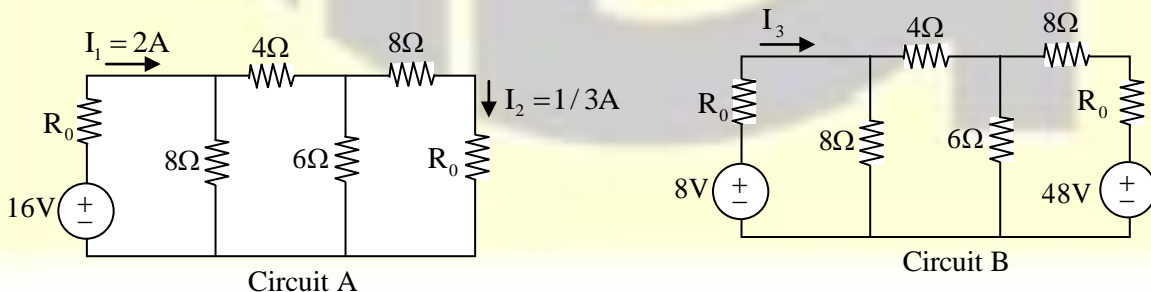

Answer: (0.0 to 0.0)

[Click here to watch video explanation](#)

55. In the balanced three-phase circuit shown, $C_0 = 8.2 \mu\text{F}$ and the line-to-line r.m.s. voltage is 440V at 50Hz. The reading on the wattmeter (in watts) is _____ (round off to two decimal places)

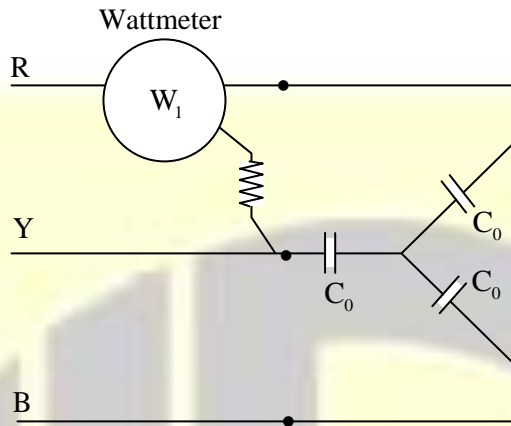

Answer: (141.80 to 146.20)

[Click here to watch video explanation](#)

56. The circuit shown is driven by a sinusoidal input voltage, V_{in} , resulting in the output voltage, V_{out} . The frequency (in kilohertz) at which the voltage gain is 0 dB is _____ (round off to two decimal places)

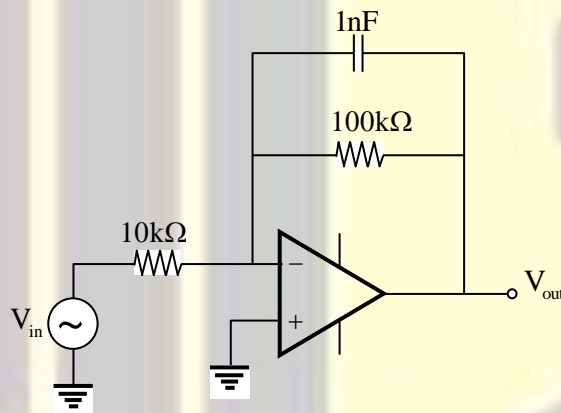

Answer: (15.80 to 16.00)

[Click here to watch video explanation](#)

57. A conducting semi-circular loop of radius $R = 0.1$ m, with its diameter centered at the origin, rotates in the x-y plane about the origin with a constant angular velocity, $\omega = 20$ rad/s, as shown. A magnetic field of magnitude $B = 2$ T and normal to x-y plane exists in the region $x \geq 0$ as shown. If the loop has a resistance of 2Ω , and negligible inductance, the peak-to-peak current (in milliamperes) in the loop is _____ (round off to one decimal place)

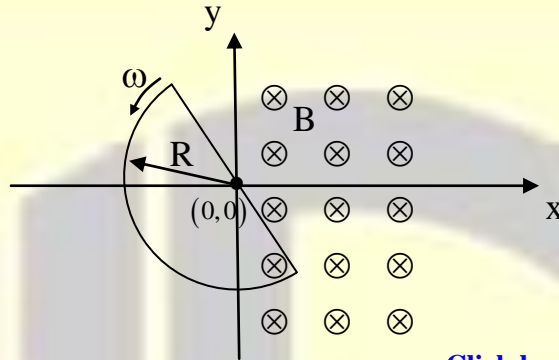

Answer: (200.0 to 200.0)

[Click here to watch video explanation](#)

58. In the circuit shown, $R_1 = 100$ k Ω and $R_2 = 1$ k Ω . If the base-to-emitter voltage of the npn BJT is 0.7 V and the collector-to-emitter voltage is 5.2 V, the β (current gain) of the BJT is _____ (round off to two decimal places)

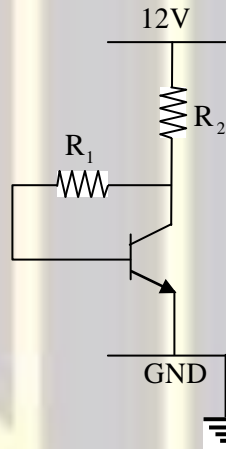

Answer: (148.00 to 152.00)

[Click here to watch video explanation](#)

59. A capacitor is constructed using two concentric spheres and air as the dielectric medium (permittivity of air = 8.854×10^{-12} F/m). The radii of the inner and outer spheres are $a = 10$ cm and $b = 15$ cm, respectively. The capacitance (in picofarads) is _____ (round off to 2 decimal places)

Answer: (32.8 to 33.9)

[Click here to watch video explanation](#)

60. A 1 kHz sine-wave generator having an internal resistance of 50Ω generates an open-circuit voltage of 10 V_{p-p} . When a capacitor is connected across the output terminals, the voltage drops to 8 V_{p-p} . The capacitance of the capacitor (in microfarads) is _____ (round off to two decimal places)

Answer: (2.35 to 2.43)

[Click here to watch video explanation](#)

61. Consider the function $f(z) = \frac{1}{(z+1)(z+2)(z+3)}$. The residue of $f(z)$ at $z = -1$, is _____

Answer: (0.49 to 0.51)

[Click here to watch video explanation](#)

62. In the circuit shown, the capacitance $C_0 = 10 \mu\text{F}$ and inductance $L_0 = 1 \text{ mH}$ and the diode is ideal. The capacitor is initially charged to 10 V and the current in the inductor is initially zero. If the switch is closed at $t = 0 \text{ s}$, the voltage $V_C(t)$ (in volts) across the capacitor at $t = 0.5 \text{ s}$ is _____ (round off to one decimal place)

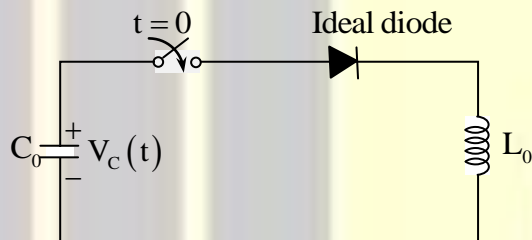

Answer: (-10.1 to -9.9)

[Click here to watch video explanation](#)

63. The bridge shown is balanced when $R_1 = 100 \Omega$, $R_2 = 210 \Omega$, $C_2 = 2.9 \mu\text{F}$, and $R_4 = 50 \Omega$. The 2 kHz sine-wave generator supplies a voltage of 10 V_{p-p} . The value of L_3 (in millihenry) is _____ (round off to two decimal places)

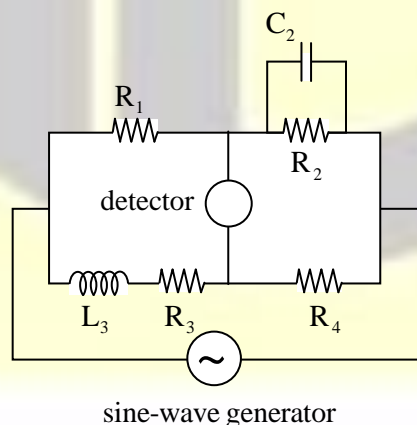

Answer: (14.40 to 14.60)

[Click here to watch video explanation](#)

64. In the circuit shown, the switch is initially closed. It is opened at $t = 0$ s and remains open thereafter. The time (in milliseconds) at which the output voltage V_{out} becomes LOW is _____ (round off to three decimal places)

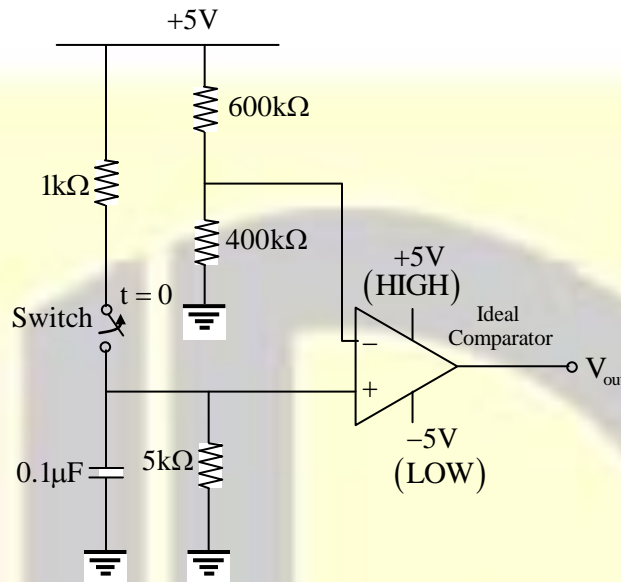

Answer: (0.365 to 0.369)

[Click here to watch video explanation](#)

65. In the Wheatstone bridge circuit shown, $R_1 = 1.5 \text{ k}\Omega$ and $R_2 = R_3 = R_4 = 1 \text{ k}\Omega$. The switch is initially open and the voltage between the points C and D is V_{CD} . Upon closing the switch at $t = 0$, the resistance in the arm AD changes by an amount δR_1 , and the voltage between C and D changes by δV_{CD} . The sensitivity of the bridge (in volt/kiloohm), defined as $\left| \frac{\delta V_{CD}}{\delta R_1} \right|$, is _____ (round off to two decimal places)

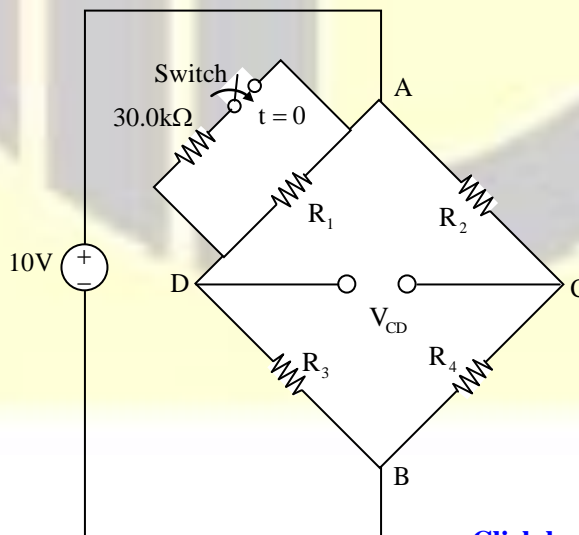

Answer: (1.62 to 1.72)

[Click here to watch video explanation](#)