



GATE PREVIOUS YEAR SOLVED PAPERS

**Mechanical Engineering
Previous Year Solved Papers**

GATEFORUM Pioneers in Digital courses for GATE since 2008 has long history of training students through innovative courses. Currently GATEFORUM offers a wide range of courses from eGATE, GATE Online, Gdrive to Online TarGATE. Since inception, we have trained more 3,00,000 students since inception.

For more details visit gateforumonline.com

GENERAL APTITUDE

Q. No. 1 - 5 Carry One Mark Each

1. After playing _____ hours of tennis, I am feeling _____ third to walk back
(A) too/two (B) two/two (C) too/too (D) two/too

Answer: (*) (MTA)

[Click here to watch video explanation](#)

2. The average of the monthly salaries of M, N and S is ₹ 4000. The average of the monthly salaries of N, S and P is ₹ 5000. The monthly salary of P is ₹ 6000.

What is the monthly salary of M as a percentage of the monthly salary of P?

- (A) 50% (B) 100 (C) 75% (D) 125%

Answer: (A)

[Click here to watch video explanation](#)

3. A person travelled 80 km in 6 hours. If the person travelled the first part with a uniform speed of 10 kmph and the remaining part with a uniform speed of 18 kmph.

What percentage of the total distance is travelled at a uniform speed of 10 kmph?

- (A) 43.75 (B) 28.25 (C) 50.00 (D) 37.25

Answer: (C)

[Click here to watch video explanation](#)

4. Four girls, P, Q, R and S are studying languages in a University. P is learning French and Dutch. Q is learning Chinese and Japanese. R is learning Spanish and French. S is learning Dutch and Japanese.

Given that French is easier than Dutch. Chinese is harder than Japanese; Dutch is easier than Japanese, and Spanish is easier than French.

Based on the above information, which girl is learning the most difficult pair of languages?

- (A) S (B) Q (C) P (D) R

Answer: (B)

[Click here to watch video explanation](#)

5.

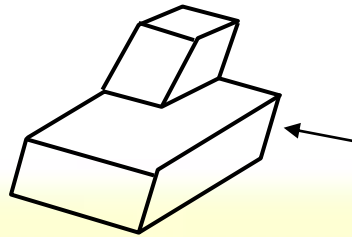

A block with a trapezoidal cross-section is placed over a block with rectangular cross section as shown above.

Which one of the following is the correct drawing of the view of the 3D object as viewed in the direction indicated by an arrow in the above figure?

(A)

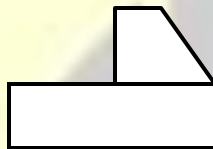

(B)



(C)



(D)

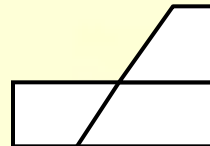

Answer: (A)

[Click here to watch video explanation](#)

Q. No. 6-10 Carry Two Marks Each

6. Humans are naturally compassionate and honest. In a study using strategically placed wallets that appear “lost”, it was found that wallets with money are more likely to be returned than wallets without money. Similarly, wallets that had a key and money are more likely to be returned than wallets with the same amount of money alone. This suggests that the primary reason for this behavior is compassion and empathy.

Which one of the following is the CORRECT logical inference based on the information in the above passage?

- (A) Wallets used in experiments are more likely to be returned than wallets that are really lost
- (B) Wallets with a key are more likely to be returned because people relate to suffering of others
- (C) Money is always more important than keys
- (D) Wallets with a key are more likely to be returned because people do not care about money

Answer: (A)

[Click here to watch video explanation](#)

7. A rhombus is formed by joining the midpoints of the sides of a unit square.
What is the diameter of the largest circle that can be inscribed within the rhombus?

(A) $\frac{1}{2\sqrt{2}}$ (B) $\frac{1}{\sqrt{2}}$ (C) $2\sqrt{2}$ (D) $\sqrt{2}$

Answer: (A)

[Click here to watch video explanation](#)

8. An equilateral triangle, a square and a circle have equal areas,
What is the ratio of the perimeters of the equilateral triangle to square to circle?

(A) $\sqrt{(3\sqrt{3})}:2:2\sqrt{\pi}$ (B) $\sqrt{(3\sqrt{3})}:4:2\sqrt{\pi}$ (C) $\sqrt{(3\sqrt{3})}:2:\sqrt{\pi}$ (D) $3\sqrt{3}:2:\sqrt{\pi}$

Answer: (B)

[Click here to watch video explanation](#)

9. Given below are three conclusions drawn based on the following three statements

Statement 1: All teachers are professors.

Statement 2: No professor is a male.

Statement 3: Some males are engineers.

Conclusion I: No engineer is a professor

Conclusion II: Some engineers are professors

Conclusion III: No male is a teacher

Which one of the following options can be logically inferred?

- (A) Only conclusion I and conclusion III are correct
(B) Only conclusion II and conclusion III are correct
(C) Only conclusion III is correct
(D) Only conclusion I and conclusion II are

Answer: (B)

[Click here to watch video explanation](#)

10. In a 12-hour clock that runs correctly, how many times do the second, minute, and hour hands of the clock coincide, in a 12-hour duration from 3 PM in a day to 3 AM the next day?

(A) 11 (B) 144 (C) 12 (D) 2

Answer: (D)

[Click here to watch video explanation](#)

MECHANICAL ENGINEERING**Q. No. 11 - 35 Carry One Mark Each**

11. The limit $p = \lim_{x \rightarrow \pi} \left(\frac{x^2 + \alpha x + 2\pi^2}{x - \pi + 2 \sin x} \right)$

has a finite value for a real α . The value of α and the corresponding limit p are

(A) $\alpha = -2\pi$, and $p = 2\pi$

(B) $\alpha = 2\pi$, and $p = 3\pi$

(C) $\alpha = -3\pi$, and $p = \pi$

(C) $\alpha = \pi$, and $p = \pi$

Answer: (C)

[Click here to watch video explanation](#)

12. Solution of $\nabla^2 T = 0$ in a square domain ($0 < x < 1$ and $0 < y < 1$) with boundary conditions:

$T(x, 0) = x$; $T(0, y) = y$; $T(x, 1) = 1 + x$; $T(1, y) = 1 + y$ is

(A) $T(x, y) = x - xy + y$

(B) $T(x, y) = x + xy + y$

(C) $T(x, y) = -x + y$

(D) $T(x, y) = x + y$

Answer: (D)

[Click here to watch video explanation](#)

13. Given a function $\phi = \frac{1}{2}(x^2 + y^2 + z^2)$ in three-dimensional Cartesian space, the value of the surface integral $\oiint_S \pi \cdot \nabla \phi dS$,

where S is the surface of a sphere of unit radius and \hat{n} is the outward unit normal vector on S , is

(A) $4\pi/3$

(B) 3π

(C) 0

(D) 4π

Answer: (D)

[Click here to watch video explanation](#)

14. The Fourier series expansion of x^3 in the interval $-1 \leq x < 1$ with periodic continuation has

(A) Only Cosine terms

(B) only sine terms

(C) Only sine terms and a non-zero constant

(D) Both sine and cosine terms

Answer: (B)

[Click here to watch video explanation](#)

15. If $A = \begin{bmatrix} 10 & 2k+5 \\ 3k-3 & k+5 \end{bmatrix}$ is a symmetric matrix, the value of k is _____

- (A) 8 (B) $\frac{1+\sqrt{1561}}{12}$ (C) 5 (D) -0.4

Answer: (A)

[Click here to watch video explanation](#)

16. A uniform light slender beam AB of section modulus EI is pinned by a frictionless joint A to the ground and supported by a light inextensible cable CB to hang a weight W as shown. Supported by a light inextensible cable CB to hang a weight W as shown. If the maximum value of W to avoid buckling of the beam AB is obtained as $\beta\pi^2EI$, where π is the ratio of circumference to diameter of a circle, then the value of β is

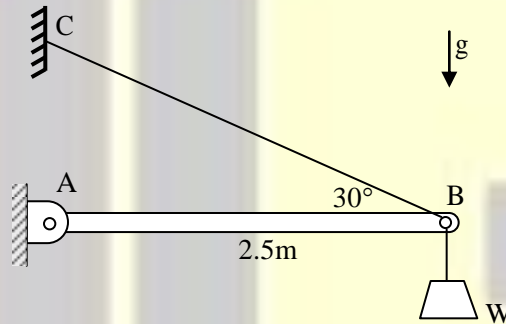

- (A) 0.0713m^{-2} (B) 0.092m^{-2} (C) 0.1417m^{-2} (D) 0.1261m^{-2}

Answer: (B)

[Click here to watch video explanation](#)

17. The figure shows a schematic of a simple Watt governor mechanism with the spindle O_1O_2 rotating at an angular velocity ω about a vertical axis. The balls at P and S have equal mass. Assume that there is no friction anywhere and all other components are massless and rigid. The vertical distance between the horizontal plane of rotation of the balls and the pivot O_1 is denoted by h. The value of $h=400\text{mm}$ is at a certain ω . If ω is doubled, the value of h will be _____ mm.

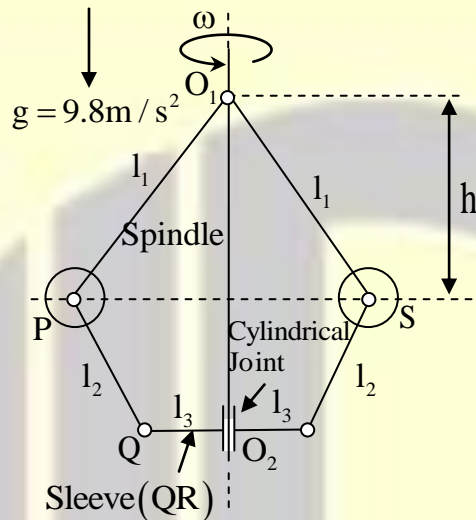

- (A) 200 (B) 150 (C) 50 (D) 100

Answer: (D)

[Click here to watch video explanation](#)

18. A square threaded screw is used to lift a load W by applying a force F. Efficiency of square threaded screw is expressed as
- (A) The ratio of work done by W per revolution to work done by F per revolution
 (B) The ratio of work done by F per revolution to work done by W per revolution.
 (C) F/W
 (D) W/F

Answer: (A)

[Click here to watch video explanation](#)

19. A CNC worktable is driven in a linear direction by a lead screw connected directly to a stepper motor. The pitch of the lead screw is 5 mm. The stepper motor completes one full revolution upon receiving 600 pulses. If the worktable speed is 5 m/minute and there is no missed pulse, then the pulse rate being received by the stepper motor is
- (A) 15kHz (B) 20kHz (C) 3 kHz (D) 10kHz

Answer: (D)

[Click here to watch video explanation](#)

20. The type of fit between a mating shaft of diameter $25.0^{+0.010}$ mm and a hole of diameter $25.015^{-0.015}$ mm is _____.

- (A) Linear (B) Transition (C) Clearance (D) Interference

Answer: (B) [Click here to watch video explanation](#)

21. In a linear programming problem, if a resource is not fully utilized, the shadow price of that resource is

- (A) positive (B) negative (C) zero (D) infinity

Answer: (C) [Click here to watch video explanation](#)

22. Which one of the following is NOT a form of inventory?

- (A) Work-in-process materials (B) CNC Milling Machines
(C) Finished goods (D) Raw materials

Answer: (B) [Click here to watch video explanation](#)

23. The Clausius inequality holds good for

- (A) Any process (B) Only reversible process
(C) Any cycle (D) Only reversible cycle

Answer: (C) [Click here to watch video explanation](#)

24. A tiny temperature probe is fully immersed in a flowing fluid and is moving with zero relative velocity with respect to the fluid. The velocity field in the fluid is $\vec{V} = (2x)\hat{i} + (y + 3t)\hat{j}$, and the temperature field in the fluid is $T = 2x^2 + xy + 4t$, where x and y are the spatial coordinates, and t is the time. The time rate of change of temperature recorded by the probe at $(x = 1, y = 1, t = 1)$ is _____

- (A) 4 (B) 0 (C) 18 (D) 14

Answer: (C) [Click here to watch video explanation](#)

25. In the following two-dimensional momentum equation for natural convection over a surface immersed in a quiescent fluid at temperature T_∞ (g is the gravitational acceleration, β is the volumetric thermal expansion coefficient, ν is the kinematic viscosity, u and v are the velocities in x and y directions, respectively, and T is the temperature)

$$u \frac{\partial u}{\partial x} + v \frac{\partial u}{\partial y} = g\beta(T - T_\infty) + \nu \frac{\partial^2 u}{\partial y^2}.$$

The term $g\beta(T - T_\infty)$ represents

- (A) Ratio of buoyancy force to viscous force. (B) Viscous force per unit mass
(C) Ratio of inertial force to viscous force. (D) Buoyancy force per unit mass.

Answer: (D)

[Click here to watch video explanation](#)

26. Assuming the material considered in each statement is homogeneous, isotropic, linear elastic, and the deformations are in the elastic range, which one or more of the following statement(s) is/are TRUE?

- (A) If a long solid steel rod is subjected to tensile load, then its volume increases.
(B) If a portion of a beam has zero shear force, then the corresponding portion of the elastic curve of the beam is always straight.
(C) Maximum shear stress theory is suitable for failure analysis of brittle materials.
(D) A body subjected to hydrostatic pressure has no shear stress.

Answer: (A, D)

[Click here to watch video explanation](#)

27. Which of the following heat treatment processes is/are used for surface hardening of steels?

- (A) Annealing (B) Carburizing (C) Cyaniding (D) Carbonitriding

Answer: (B, C, D)

[Click here to watch video explanation](#)

28. Which of the following additive manufacturing techniques (s) can use a wire as a feedstock material?

- (A) Stereolithography (B) Directed energy deposition processes
(C) Selective laser sintering (D) Fused deposition modeling

Answer: (B, D)

[Click here to watch video explanation](#)

29. Which of the following methods can improve the fatigue strength of a circular mild steel (MS) shaft?

- (A) Increasing relative humidity (B) Shot peening of the shaft
(C) Reducing relative humidity (D) Enhancing surface finish

Answer: (B, C, D)

[Click here to watch video explanation](#)

30. The figure shows a purely convergent nozzle with a steady, inviscid compressible flow of an ideal gas with constant thermophysical properties operating under choked condition. The exit plane shown in the figure is located within the nozzle. If the inlet pressure (P_0) is increased while keeping the back pressure (P_{back}) unchanged, which of the following statements is/are true?

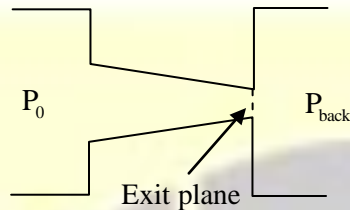

- (A) Mach number at the exit plane of the nozzle will become more than unity.
- (B) Mass flow rate through the nozzle will remain unchanged.
- (C) Mach number at the exit plane of the nozzle will remain unchanged at unity.
- (D) Mass flow rate through the nozzle will increase.

Answer: (C, D)

[Click here to watch video explanation](#)

31. The plane of the figure represents a horizontal plane. A thin rigid rod at rest is pivoted without friction about a fixed vertical axis passing through O. Its mass moment of inertia is equal to $0.1 \text{ kg}\cdot\text{cm}^2$ about O. A point mass of 0.001 kg hits it normally at 200 cm/s at the location shown, and sticks to it. Immediately after the impact, the angular velocity of the rod is _____ rad/s (in integer).

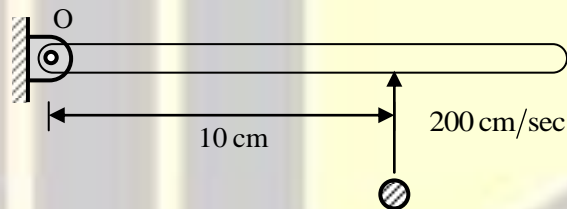

Answer: (10 to 10)

[Click here to watch video explanation](#)





GATE REFRESHER COURSE
Mechanical Engineering

GATEFORUM Pioneers in Digital courses for GATE since 2008 offers **GATE refresher course** giving you access to video solutions for previous 11 years GATE questions and Topic-wise formula Compendium (Handbook).

**Enroll now and get 20% discount use
Promo Code **GATEPAPERS****

For more details visit gateforumonline.com

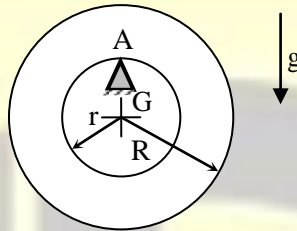
32. A rigid uniform annular disc is pivoted on a knife edge A in a uniform gravitational field as shown, such that it can execute small amplitude simple harmonic motion in the plane of the figure without slip at the pivot point. The inner radius r and outer radius R are such that $r^2 = R^2/2$, and the acceleration due to gravity is g . If the time period of small amplitude simple harmonic motion is given by $T = \beta\pi\sqrt{R/g}$ where π is the ratio of circumference to diameter of a circle, then $\beta =$ _____ (round off to 2 decimal places).



Answer: (2.62 to 2.70)

[Click here to watch video explanation](#)

33. Electrochemical machining operations are performed with tungsten as the tool, and copper and aluminum as two different workpiece materials. Properties of copper and aluminum are given in the table below.

Material	Atomic mass (amu)	Valency	Density (g/cm ³)
Copper	63	2	9
Aluminum	27	3	2.7

Ignore overpotentials, and assume that current efficiency is 100% for both the workpiece materials. Under identical conditions, if the material removal rate (MRR) of copper is 100mg/s, the MRR of aluminum will be _____ mg/s (round-off to two decimal places).

Answer: (27.00 to 30.00)

[Click here to watch video explanation](#)

34. A polytropic process is carried out from an initial pressure of 110 kPa and volume of 5m³ to a final volume of 2.5m³. The polytropic index is given by $n = 1.2$. The absolute value of the work done during the process is _____ kJ (round off to 2 decimal places).

Answer: (404.00 to 414.00)

[Click here to watch video explanation](#)

35. A flat plate made of cast iron is exposed to a solar flux of 600 W/m^2 at an ambient temperature of 25°C . Assume that the entire solar flux is absorbed by the plate.
- Cast iron has a low temperature absorptivity of 0.21. Use Stefan-Boltzmann constant = $5.669 \times 10^{-8} \text{ W/m}^2\text{-K}^4$. Neglect all other modes of heat transfer except radiation.
- Under the aforementioned conditions, the radiation equilibrium temperature of the plate is _____ $^\circ\text{C}$ (round off to the nearest integer).

Answer: (210 to 225)

[Click here to watch video explanation](#)

Q. No. 36-65 Carry Two Marks Each

36. The value of the integral

$$\oint \left(\frac{6z}{2z^4 - 3z^3 + 7z^2 - 3z + 5} \right) dz$$

evaluated over a counter-clockwise circular contour in the complex plane enclosing only the pole $z = i$, where i is the imaginary unit, is

- (A) $(2+i)\pi$ (B) $(-1+i)\pi$ (C) $(1+i)\pi$ (D) $2(1-i)\pi$

Answer: (B)

[Click here to watch video explanation](#)

37. An L-shaped elastic member ABC with slender arms AB and BC of uniform cross-section is clamped at end A and connected to a pin at end C. The pin remains in continuous contact with and is constrained to move in a smooth horizontal slot. The section modulus of the member is same in both the arms. The end C is subjected to a horizontal force P and all the deflections are in the plane of the figure. Given the length AB is $4a$ and length BC is a , the magnitude and direction of the normal force on the pin from the slot, respectively, are

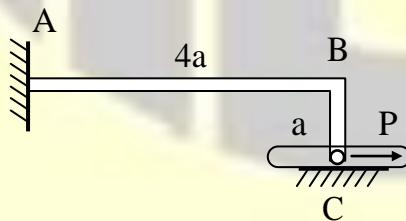

- (A) $3P/4$, and upwards (B) $5P/8$ and upwards
(C) $P/4$, and downwards (D) $3P/8$, and downwards

Answer: (D)

[Click here to watch video explanation](#)

38. A planar four-bar linkage mechanism with 3 revolute kinematic pairs and 1 prismatic kinematic pair is shown in the figure, where $AB \perp CE$ and $FD \perp CE$. The T-shaped link CDEF is constructed such that the slider B can cross the point D, and CE is sufficiently long. For the given lengths as shown, the mechanism is

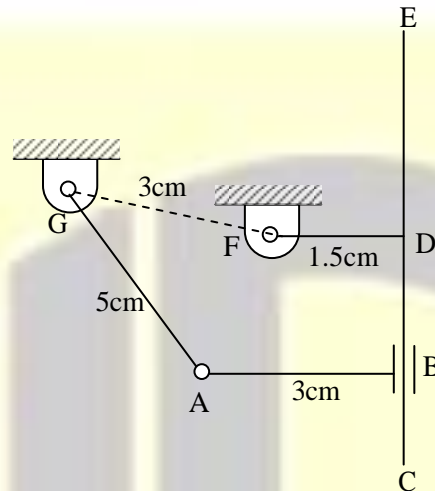

- (A) A non-Grashof chain with all oscillating links
- (B) On the border of Grashof and non-Grashof chains with uncertain configurations(s)
- (C) a Grashof chain with AB completely rotatable about the ground link FG, and oscillatory links AG and CDEF
- (D) A Grashof chain with links AG, AB, and CDEF completely rotatable about the ground link FG

Answer: (D)

[Click here to watch video explanation](#)

39. Consider a forced single degree-of-freedom system governed by $\ddot{x}(t) + 2\xi\omega_n\dot{x}(t) + \omega_n^2 x(t) = \omega_n^2 \cos(\omega t)$, where ξ and ω_n are the damping ratio and undamped natural frequency of the system, respectively, while ω is the forcing frequency. The amplitude of the forced steady state response of this system is given by $[(1 - r^2)^2 + (2\xi r)^2]^{-1/2}$, where $r = \omega / \omega_n$. The peak amplitude of this response occurs at a frequency $\omega = \omega_p$. If ω_d denotes the damped natural frequency of this system, which one of the following options is true?

- (A) $\omega_d < \omega_n = \omega_p$
- (B) $\omega_d < \omega_n < \omega_p$
- (C) $\omega_p < \omega_d < \omega_n$
- (D) $\omega_p = \omega_d < \omega_n$

Answer: (C)

[Click here to watch video explanation](#)

40. A bracket is attached to a vertical column by means of two identical rivets U and V separated by a distance of $2a = 100$ mm, as shown in the figure. The permissible shear stress of the rivet material is 50 MPa. If a load $P = 10$ kN is applied at an eccentricity $e = 3\sqrt{7}a$, the minimum cross-sectional area of each of the rivets to avoid failure is _____ mm^2 .

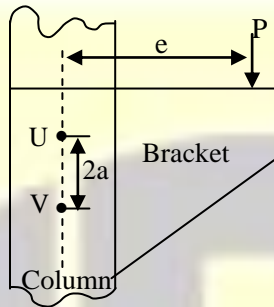

- (A) 800 (B) $100\sqrt{7}$ (C) 200 (D) 25

Answer: (A)

[Click here to watch video explanation](#)

41. In Fe-Fe₃C phase diagram, the eutectoid composition is 0.8 weight % of carbon at 725 °C. The maximum solubility of carbon in α -ferrite phase is 0.025 weight % of carbon. A steel sample, having no other alloying element except 0.5 weight % of carbon, is slowly cooled from 1000°C to room temperature. The fraction of pro-eutectoid α -ferrite in the above steel sample at room temperature is

- (A) 0.775 (B) 0.864 (C) 0.387 (D) 0.475

Answer: (C)

[Click here to watch video explanation](#)

42. Activities A to K are required to complete a project. The time estimates and the immediate predecessors of these activities are given in the table. If the project is to be completed in the minimum possible time, the latest finish time for the activity G is _____ hours.

Activity	Time (hours)	Immediate Predecessors
A	2	-
B	3	-
C	2	-
D	4	A
E	5	B
F	4	B
G	3	C
H	10	D,E
I	5	F
J	8	G
K	3	H,I,J

- (A) 10 (B) 8 (C) 5 (D) 9

Answer: (A)

[Click here to watch video explanation](#)

43. A solid spherical bead of lead (uniform density= 11000kg/m^3) of diameter $d=0.1\text{mm}$ sinks with a constant velocity V in large stagnant pool of a liquid (dynamic viscosity= $1.1\times 10^{-3}\text{kgm}^{-1}\text{s}^{-1}$). The coefficient of drag is given by $C_D = \frac{24}{\text{Re}}$, where the Reynolds number (Re) is defined on the basis of the diameter of the bead. The drag force acting on the bead is expressed as $D = (C_D)(0.5\rho V^2)\left(\frac{\pi d^2}{4}\right)$, where ρ is the density of the liquid. Neglect the buoyancy force. Using $g=10\text{m/s}^2$, the velocity V is _____ m/s.

- (A) $\frac{1}{6}$ (B) $\frac{1}{18}$ (C) $\frac{1}{24}$ (D) $\frac{1}{12}$

Answer: (B)

[Click here to watch video explanation](#)

44. Consider steady, one-dimensional compressible flow of a gas in a pipe of diameter 1 m. At one location in the pipe, the density and velocity are 1 kg/m^3 and 100 m/s , respectively. At a downstream location in the pipe, the velocity is 170 m/s . If the pressure drop between these two locations is 10 kPa , the force exerted by the gas on the pipe between these two locations is _____ N.
- (A) 750π (B) 1000π (C) 3000 (D) $350\pi^2$

Answer: (A)

[Click here to watch video explanation](#)

45. Consider a rod of uniform thermal conductivity whose one end ($x = 0$) is insulated and the other end ($x = L$) is exposed to flow of air at temperature T_∞ with convective heat transfer coefficient h . The cylindrical surface of the rod is insulated so that the heat transfer is strictly along the axis of the rod. The rate of internal heat generation per unit volume inside the rod is given as

$$\dot{q} = \cos \frac{2\pi x}{L}$$

The steady state temperature at the mid-location of the rod is given as T_A . What will be the temperature at the same location, if the convective heat transfer coefficient increases to $2h$?

- (A) $T_A \left(1 - \frac{\dot{q}L}{4\pi h} \right) + \frac{\dot{q}L}{4\pi h} T_\infty$ (B) $T_A + \frac{\dot{q}L}{2h}$
 (C) $2T_A$ (D) T_A

Answer: (D)

[Click here to watch video explanation](#)

46. The system of linear equations in real (x, y) given by

$$\begin{pmatrix} x & y \end{pmatrix} \begin{bmatrix} 2 & 5-2\alpha \\ \alpha & 1 \end{bmatrix} = \begin{pmatrix} 0 & 0 \end{pmatrix}$$

involves real parameter α and has infinitely many non-trivial solutions for special value(s) of α . Which one or more among the following options is/are non-trivial solutions (s) of (x, y) for such special value (s) of α ?

- A) $x = 1, y = 1$ B) $x = 2, y = -2$ C) $x = -1, y = 4$ D) $x = 4, y = -2$

Answer: (B, C)

[Click here to watch video explanation](#)

47. Let a random variable X follow Poisson distribution such that
 $\text{Prob}(X=1) = \text{Prob}(X=2)$
 The value of $\text{Prob}(X=3)$ is _____ (round off to 2 decimal places).

Answer: (0.17 to 0.19)

[Click here to watch video explanation](#)

48. Consider two vectors:

$$\vec{a} = 5\mathbf{i} + 7\mathbf{j} + 2\mathbf{k}$$

$$\vec{b} = 3\mathbf{i} - \mathbf{j} + 6\mathbf{k}$$

Magnitude of the component of \vec{a} orthogonal to \vec{b} in the plane containing the vectors \vec{a} and \vec{b} is _____ (round off to 2 decimal places)

Answer: (7.90 to 8.70)

[Click here to watch video explanation](#)

49. A structure, along with the loads applied on it, is shown in the figure. Self-weight of all the members is negligible and all the pin joints are friction-less. AE is a single member that contains pin C. Likewise, BE is a single member that contains pin D. Members GI and FH are overlapping rigid members. The magnitude of the force carried by member CI is _____ kN (in integer).

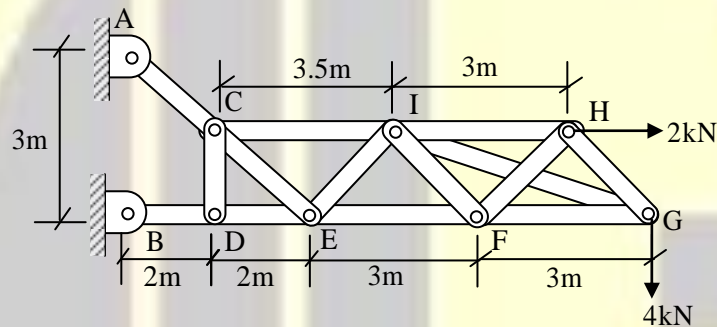

Answer: (18 to 18)

[Click here to watch video explanation](#)

50. Two rigid massless rods PR and RQ are joined at frictionless pin-joint R and are resting on ground at P and Q, respectively, as shown in the figure. A vertical force F acts on the pin R as shown. When the included angle $\theta < 90^\circ$, the rods remain in static equilibrium due to Coulomb friction between the rods and ground at locations P and Q. At $\theta = 90^\circ$, impending slip occurs simultaneously at points P and Q. Then the ratio of the coefficient of friction at Q to that at P (μ_Q / μ_P) is _____ (round off to two decimal places).

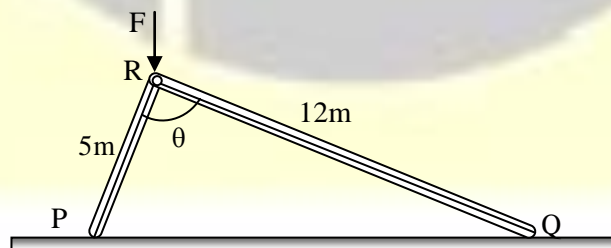

Answer: (5.70 to 5.80)

[Click here to watch video explanation](#)

51. A cylindrical disc of mass $m = 1$ kg and radius $r = 0.15$ m was spinning at $\omega = 5$ rad/s when it was placed on a flat horizontal surface and released (refer to the figure). Gravity g acts vertically downwards as shown in the figure. The coefficient of friction between the disc and the surface is finite and positive. Disregarding any other dissipation except that due to friction between the disc and the surface, the horizontal velocity of the center of the disc, when it starts rolling without slipping, will be _____ m/s (round off to 2 decimal places).

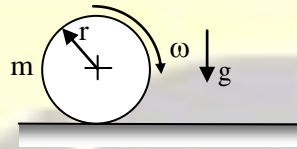

Answer: (0.24 to 0.26)

[Click here to watch video explanation](#)

52. A thin-walled cylindrical pressure vessel has mean wall thickness of t and nominal radius of r . The Poisson's ratio of the wall material is $1/3$. When it was subjected to some internal pressure, its nominal perimeter in the cylindrical portion increased by 0.1% and the corresponding wall thickness became \bar{t} . The corresponding change in the wall thickness of the cylindrical portion, i.e. $100(\bar{t} - t)/t$, is _____% (round off to 3 decimal places).

Answer: (-0.062 to -0.058)

[Click here to watch video explanation](#)

53. A schematic of an epicyclic gear train is shown in the figure. The sun (gear 1) and planet (gear 2) are external, and the ring gear (gear 3) is internal. Gear 1, gear 3 and arm OP are pivoted to the ground at O. Gear 2 is carried on the arm OP via the pivot joint at P, and is in mesh with the other two gears. Gear 2 has 20 teeth and gear 3 has 80 teeth. If gear 1 is kept fixed at 0 rpm and gear 3 rotates at 900 rpm counter clockwise (ccw), the magnitude of angular velocity of arm OP is _____ rpm (in integer).

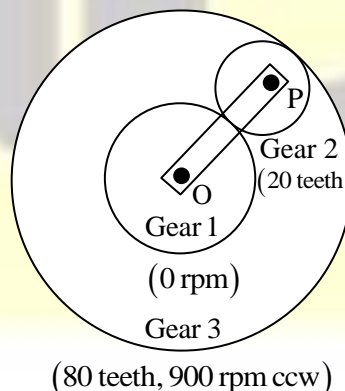

Answer: (600 to 600)

[Click here to watch video explanation](#)

54. Under orthogonal cutting condition, a turning operation is carried out on a metallic workpiece at a cutting speed of 4 m/s. The orthogonal rake angle of the cutting tool is 5° . The uncut chip thickness and width of cut are 0.2 mm and 3 mm respectively. In this turning operation, the resulting friction angle and shear angle are 45° and 25° respectively. If the dynamic yield shear strength of the workpiece material under this cutting condition is 1000 MPa then the cutting force is _____ N (round off to one decimal place).

Answer: (2570.0 to 2576.0)

[Click here to watch video explanation](#)

55. A 1 mm thick cylindrical tube, 100 mm in diameter, is orthogonally turned such that the entire wall thickness of the tube is cut in a single pass. The axial feed of the tool is 1 mm/minute and the specific cutting energy (u) of the tube material is 6 J/mm^3 . Neglect contribution of feed force towards power. The power required to carry out this operation is _____ kW (round off to one decimal place).

Answer: (30.0 to 32.0)

[Click here to watch video explanation](#)

56. A 4 mm thick aluminum sheet of width $w = 100 \text{ mm}$ is rolled in a two-roll mill of roll diameter 200 mm each. The workpiece is lubricated with a mineral oil, which gives a coefficient of friction $\mu = 0.1$. The flow stress (σ) of the material in MPa is $\sigma = 207 + 414\varepsilon$, where ε is the true strain. Assuming rolling to be a plane strain deformation process, the roll separation force (F) for maximum permissible draft (thickness reduction) is _____ kN (round off to the nearest integer).

Use:

$F = 1.15\bar{\sigma} \left(1 + \frac{\mu L}{2h} \right) wL$, where $\bar{\sigma}$ is average flow stress, L is roll-workpiece contact length, and \bar{h} is the average sheet thickness.

Answer: (340 to 360)

[Click here to watch video explanation](#)

57. Two mild steel plates of similar thickness, in butt-joint configuration, are welded by gas tungsten arc welding process using the following welding parameters.

Welding voltage	20V
Welding current	150 A
Welding speed	5 mm/s

A filler wire of the same mild steel material having 3 mm diameter is used in this welding process. The filler wire feed rate is selected such that the final weld bead is composed of 60% volume of filler and 40% volume of plate material. The heat required to melt the mild steel material is 10J/mm^3 . The heat transfer factor is 0.7 and melting factor is 0.6. The feed rate of the filler wire is _____ mm/s (round off to one decimal place).

Answer: (10.5 to 10.9)

[Click here to watch video explanation](#)

58. An assignment problem is solved to minimize the total processing time of four jobs (1, 2, 3 and 4) on four different machines such that each job is processed exactly by one machine and each machine processes exactly one job. The minimum total processing time is found to be 500 minutes. Due to a change in design, the processing time of Job 4 on each machine has increased by 20 minutes. The revised minimum total processing time will be _____ minutes (in integer).

Answer: (520 to 520)

[Click here to watch video explanation](#)

59. The product structure diagram shows the number of different components required at each level to produce one unit of the final product P. If there are 50 units of on-hand inventory of component A, the number of additional units of component A needed to produce 10 units of product P is _____ (in integer).

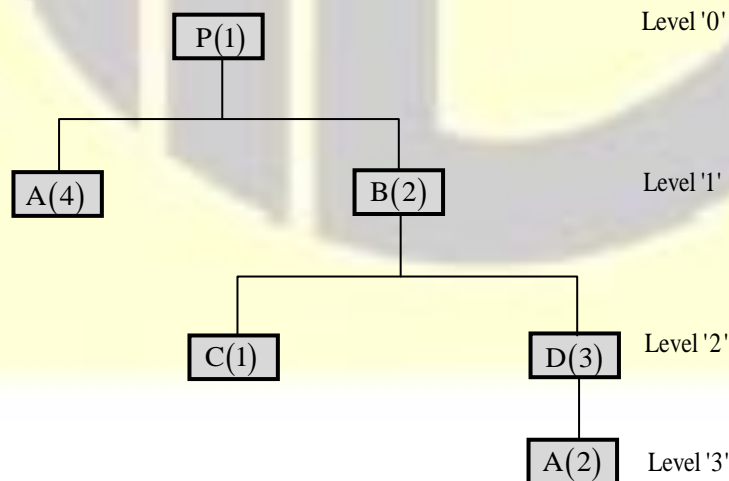

Answer: (110 to 110)

[Click here to watch video explanation](#)

60. Consider a one-dimensional steady heat conduction process through a solid slab of thickness 0.1m. The higher temperature side A has a surface temperature of 80°C. and the heat transfer rate per unit area to low temperature side B is 4.5 kW/m². The thermal conductivity of the slab is 15W/m.K. The rate of entropy generation per unit area during the heat transfer process is _____ W/m².K (round off to 2 decimal places).

Answer: (1.12 to 1.24)

[Click here to watch video explanation](#)

61. In a steam power plant based on Rankine cycle, steam is initially expanded in a high-pressure turbine. The steam is then reheated in a reheater and finally expanded in a low-pressure turbine. The expansion work in the high-pressure turbine is 400 kJ/kg and in the low-pressure turbine is 850 kJ/kg, whereas the pump work is 15 kJ/kg. If the cycle efficiency is 32%, the heat rejected in the condenser is _____ kJ/kg (round off to 2 decimal places).

Answer: (2620.00 to 2630.00)

[Click here to watch video explanation](#)

62. An engine running on an air standard Otto cycle has a displacement volume 250 cm³ and a clearance volume 35.7 cm³. The pressure and temperature at the beginning of the compression process are 100 kPa and 300 K, respectively. Heat transfer during constant-volume heat addition process is 800 kJ/kg. The specific heat at constant volume is 0.718 kJ/kg.K and the ratio of specific heats at constant pressure and constant volume is 1.4. Assume the specific heats to remain constant during the cycle. The maximum pressure in the cycle is _____ kPa (round off to the nearest integer).

Answer: (4780 to 4825)

[Click here to watch video explanation](#)

63. A steady two-dimensional flow field is specified by the stream function $\Psi = kx^3y$, where x and y are in meter and the constant $k = 1\text{m}^{-2}\text{s}^{-1}$. The magnitude of acceleration at a point (x, y) = (1m, 1m) is _____ m/s² (round off to 2 decimal places)

Answer: (4.20 to 4.28)

[Click here to watch video explanation](#)

64. Consider a solid slab (thermal conductivity, $k = 10 \text{ W.m}^{-1} \cdot \text{K}^{-1}$) with thickness 0.2 m and of infinite extent in the other two directions as shown in the figure. Surface 2, at 300 K . is exposed to a fluid flow at a free stream temperature (T_∞) of 293 K , with a convective heat transfer coefficient (h) of $100 \text{ W.m}^{-2} \cdot \text{K}^{-1}$. Surface 2 is opaque, diffuse and gray with an emissivity (ϵ) of 0.5 and exchanges heat by radiation with very large surroundings at 0 K . Radiative heat transfer inside the solid slab is neglected. The Stefan-Boltzmann constant is $5.67 \times 10^{-8} \text{ W.m}^{-2} \cdot \text{K}^{-4}$. The temperature T_1 of Surface 1 of the slab, under steady-state conditions, is _____ K (round off to the nearest integer).

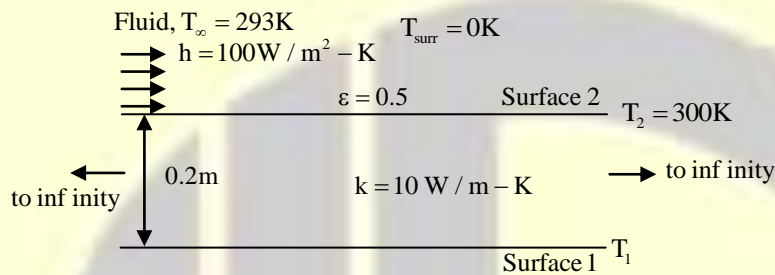

Answer: (315 to 323)

[Click here to watch video explanation](#)

65. During open-heart surgery, a patient's blood is cooled down to 25°C from 37°C using a concentric tube counter-flow heat exchanger. Water enters the heat exchanger at 4°C and leaves at 18°C . Blood flow rate during the surgery is 5 L/minute .

Use the following fluid properties:

Fluid	Density (kg/m^3)	Specific heat (J/kg-K)
Blood	1050	3740
Water	1000	4200

Effectiveness of the heat exchanger is _____ (round off to 2 decimal places).

Answer: (0.40 to 0.44)

[Click here to watch video explanation](#)





Follow us @



For more details visit gateforumonline.com