



*GATE PREVIOUS YEAR SOLVED PAPERS*

## Computer Science Engineering Previous Year Solved Papers

**GATEFORUM** Pioneers in Digital courses for GATE since 2008 has long history of training students through innovative courses. Currently GATEFORUM offers a wide range of courses from eGATE, GATE Online, Gdrive to Online TarGATE. Since inception, we have trained more 3,00,000 students since inception.

**For more details visit [gateforumonline.com](http://gateforumonline.com)**

## GENERAL APTITUDE

### Q. No. 1 - 5 Carry One Mark Each

1. We reached the station late, and missed the train.

- (A) near                      (B) nearly                      (C) utterly                      (D) mostly

**Answer:** (B)

[Click here to watch video explanation](#)

2. Kind : : Often : Frequently

(By word meaning)

- (A) Mean                      (B) Type                      (C) Cruel                      (D) Kindly

**Answer:** (B)

[Click here to watch video explanation](#)

3. A series of natural numbers  $F_1, F_2, F_3, F_4, F_5, F_6, F_7, \dots$  obeys  $F_{n+1} = F_n + F_{n-1}$  for all integers  $n \geq 2$ .

If  $F_6 = 37$  and  $F_7 = 60$ , then what is  $F_1$  ?

- (A) 4                      (B) 5                      (C) 8                      (D) 9

**Answer:** (A)

[Click here to watch video explanation](#)

4. A survey for a certain year found that 90% of pregnant women received medical care at least once before giving birth. Of these women, 60% received medical care from doctors, while 40% received medical care from other healthcare providers.

Given this information, which one of the following statements can be inferred with certainty?

- (A) More than half of the pregnant women received medical care at least once from a doctor.  
(B) Less than half of the pregnant women received medical care at least once from a doctor.  
(C) More than half of the pregnant women received medical care at most once from a doctor.  
(D) Less than half of the pregnant women received medical care at most once from a doctor.

**Answer:** (A)

[Click here to watch video explanation](#)

5. Looking at the surface of a smooth 3-dimensional object from the outside, which one of the following options is TRUE?
- (A) The surface of the object must be concave everywhere.
  - (B) The surface of the object must be convex everywhere.
  - (C) The surface of the object may be concave in some places and convex in other places.
  - (D) The object can have edges, but no corners.

**Answer:** (C)

[Click here to watch video explanation](#)

Q. No. 6-10 Carry Two Marks Each

6. The country of Zombieland is in distress since more than 75% of its working population is suffering from serious health issues. Studies conducted by competent health experts concluded that a complete lack of physical exercise among its working population was one of the leading causes of their health issues. As one of the measures to address the problem, the Government of Zombieland has decided to provide monetary incentives to those who ride bicycles to work.

Based only on the information provided above, which one of the following statements can be logically inferred with certainty?

- (A) All the working population of Zombieland will henceforth ride bicycles to work.
- (B) Riding bicycles will ensure that all of the working population of Zombieland is free of health issues.
- (C) The health experts suggested to the Government of Zombieland to declare riding bicycles as mandatory.
- (D) The Government of Zombieland believes that riding bicycles is a form of physical exercise.

**Answer:** (D)

[Click here to watch video explanation](#)

7. Consider two functions of time (t),

$$f(t) = 0.01 t^2$$

$$g(t) = 4t$$

Where  $0 < t < \infty$ .

Now consider the following two statements:

- (i) For some  $t > 0$ ,  $g(t) > f(t)$ .
- (ii) There exists a T, such that  $f(t) > g(t)$  for all  $t > T$ .

Which one of the following options is TRUE?

- (A) only (i) is correct  
(B) only (ii) is correct  
(C) both (i) and (ii) are correct  
(D) neither (i) nor (ii) is correct

**Answer:** (C)

[Click here to watch video explanation](#)

8. Which one of the following sentence sequences creates a coherent narrative?

- (i) Once on the terrace, on her way to her small room in the corner, she notices the man right away.  
(ii) She begins to pant by the time she has climbed all the stairs.  
(iii) Mina has bought vegetables and rice at the market, so her bags are heavy.  
(iv) He was leaning against the parapet, watching the traffic below.

- (A) (i), (ii), (iv), (iii)                      (B) (ii), (iii), (i), (iv)  
(C) (iv), (ii), (i), (iii)                      (D) (iii), (ii), (i), (iv)

**Answer:** (D)

[Click here to watch video explanation](#)

9.  $f(x)$  and  $g(y)$  are functions of  $x$  and  $y$ , respectively, and  $f(x) = g(y)$  for all real values of  $x$  and  $y$ . Which one of the following options is necessarily TRUE for all  $x$  and  $y$ ?

- (A)  $f(x) = 0$  and  $g(y) = 0$                       (B)  $f(x) = g(y) = \text{constant}$   
(C)  $f(x) \neq \text{constant}$  and  $g(y) \neq \text{constant}$                       (D)  $f(x) + g(y) = f(x) - g(y)$

**Answer:** (B)

[Click here to watch video explanation](#)

10. Which one of the options best describes the transformation of the 2-dimensional figure P to Q, and then to R, as shown?

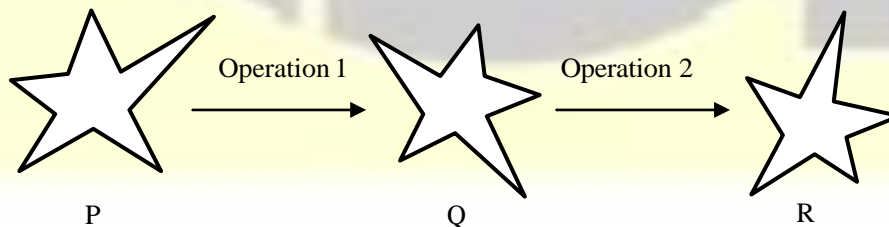

- (A) Operation 1: A clockwise rotation by  $90^\circ$  about an axis perpendicular to the plane of the figure  
Operation 2: A reflection along a horizontal line
- (B) Operation 1: A counter clockwise rotation by  $90^\circ$  about an axis perpendicular to the plane of the figure  
Operation 2: A reflection along a horizontal line
- (C) Operation 1: A clockwise rotation by  $90^\circ$  about an axis perpendicular to the plane of the figure  
Operation 2: A reflection along a vertical line
- (D) Operation 1: A counter clockwise rotation by  $180^\circ$  about an axis perpendicular to the plane of the figure  
Operation 2: A reflection along a vertical line

**Answer:** (A)

[Click here to watch video explanation](#)

## COMPUTER SCIENCE & INFORMATION TECHNOLOGY

### Q. No. 1 to 25 Carry One Mark Each

1. Consider the following statements regarding the front-end and back-end of a compiler.  
S1: The front-end includes phases that are independent of the target hardware.  
S2: The back-end includes phases that are specific to the target hardware.  
S3: The back-end includes phases that are specific to the programming language used in the source code.  
Identify the CORRECT option.
- (A) Only S1 is TRUE. (B) Only S1 and S2 are TRUE.  
(C) S1, S2, and S3 are all TRUE. (D) Only S1 and S3 are TRUE.

**Answer:** (B)

[Click here to watch video explanation](#)

2. Which one of the following sequences when stored in an array at locations  $A[1], \dots, A[10]$  forms a max-heap?
- (A) 23, 17, 10, 6, 13, 14, 1, 5, 7, 12 (B) 23, 17, 14, 7, 13, 10, 1, 5, 6, 12  
(C) 23, 17, 14, 6, 13, 10, 1, 5, 7, 15 (D) 23, 14, 17, 1, 10, 13, 16, 12, 7, 5

**Answer:** (B)

[Click here to watch video explanation](#)

3. Let SLLdel be a function that deletes a node in a singly-linked list given a pointer to the node and a pointer to the head of the list. Similarly, let DLLdel be another function that deletes a node in a doubly-linked list given a pointer to the node and a pointer to the head of the list.

Let  $n$  denote the number of nodes in each of the linked lists. Which one of the following choices is TRUE about the worst-case time complexity of SLLdel and DLLdel?

- (A) SLLdel is  $O(1)$  and DLLdel is  $O(n)$
- (B) Both SLLdel and DLLdel are  $O(\log(n))$
- (C) Both SLLdel and DLLdel are  $O(1)$
- (D) SLLdel is  $O(n)$  and DLLdel is  $O(1)$

**Answer: (D)**

[Click here to watch video explanation](#)

4. Consider the Deterministic Finite-state Automaton (DFA) A shown below. The DFA runs on the alphabet  $\{0, 1\}$ , and has the set of states  $\{s, p, q, r\}$ , with  $s$  being the start state and  $p$  being the only final state.

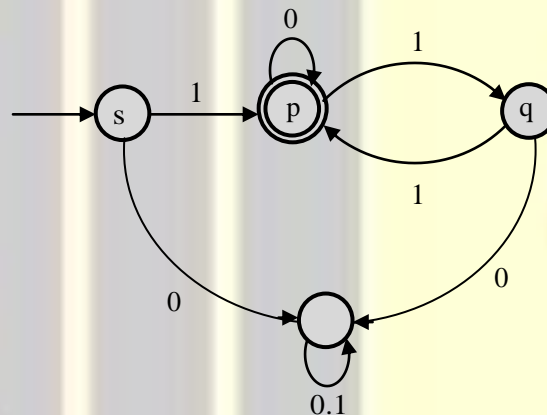

Which one of the following regular expressions correctly describes the language accepted by A?

- (A)  $1(0^*11)^*$
- (B)  $0(0 + 1)^*$
- (C)  $1(0 + 11)^*$
- (D)  $1(110)^*$

**Answer: (C)**

[Click here to watch video explanation](#)

5. The Lucas sequence  $L_n$  is defined by the recurrence relation:

$$L_n = L_{n-1} + L_{n-2}, \text{ for } n \geq 3,$$

With  $L_1 = 1$  and  $L_2 = 3$ .

Which one of the options given is TRUE?

(A)  $L_n = \left(\frac{1+\sqrt{5}}{2}\right)^n + \left(\frac{1-\sqrt{5}}{2}\right)^n$

(B)  $L_n = \left(\frac{1+\sqrt{5}}{2}\right)^n - \left(\frac{1-\sqrt{5}}{3}\right)^n$

(C)  $L_n = \left(\frac{1+\sqrt{5}}{2}\right)^n + \left(\frac{1-\sqrt{5}}{3}\right)^n$

(D)  $L_n = \left(\frac{1+\sqrt{5}}{2}\right)^n - \left(\frac{1-\sqrt{5}}{2}\right)^n$

**Answer:** (A)

[Click here to watch video explanation](#)

6. Which one of the options given below refers to the degree (or arity) of a relation in relational database systems?

- (A) Number of attributes of its relation schema.
- (B) Number of tuples stored in the relation.
- (C) Number of entries in the relation.
- (D) Number of distinct domains of its relation schema.

**Answer:** (A)

[Click here to watch video explanation](#)

7. Suppose two hosts are connected by a point-to-point link and they are configured to use Stop-and-Wait protocol for reliable data transfer. Identify in which one of the following scenarios, the utilization of the link is the lowest.

- (A) Longer link length and lower transmission rate
- (B) Longer link length and higher transmission rate
- (C) Shorter link length and lower transmission rate
- (D) Shorter link length and higher transmission rate

**Answer:** (A)

[Click here to watch video explanation](#)

8. Let  $A = \begin{bmatrix} 1 & 2 & 3 & 4 \\ 4 & 1 & 2 & 3 \\ 3 & 4 & 1 & 2 \\ 2 & 3 & 4 & 1 \end{bmatrix}$  and  $B = \begin{bmatrix} 3 & 4 & 1 & 2 \\ 4 & 1 & 2 & 3 \\ 1 & 2 & 3 & 4 \\ 2 & 3 & 4 & 1 \end{bmatrix}$

Let  $\det(A)$  and  $\det(B)$  denote the determinants of the matrices A and B, respectively.

Which one of the options given below is TRUE?

- (A)  $\det(A) = \det(B)$
- (B)  $\det(B) = -\det(A)$
- (C)  $\det(A) = 0$
- (D)  $\det(AB) = \det(A) + \det(B)$

**Answer:** (B)

[Click here to watch video explanation](#)

9. Consider the following definition of a lexical token id for an identifier in a programming language, using extended regular expressions:

**letter**  $\rightarrow$  [A-Za-z]

**digit**  $\rightarrow$  [0-9]

**id**  $\rightarrow$  letter (letter | digit)\*

Which one of the following Non-deterministic Finite-state Automata with  $\epsilon$ -transitions accepts the set of valid identifiers? (A double-circle denotes a final state)

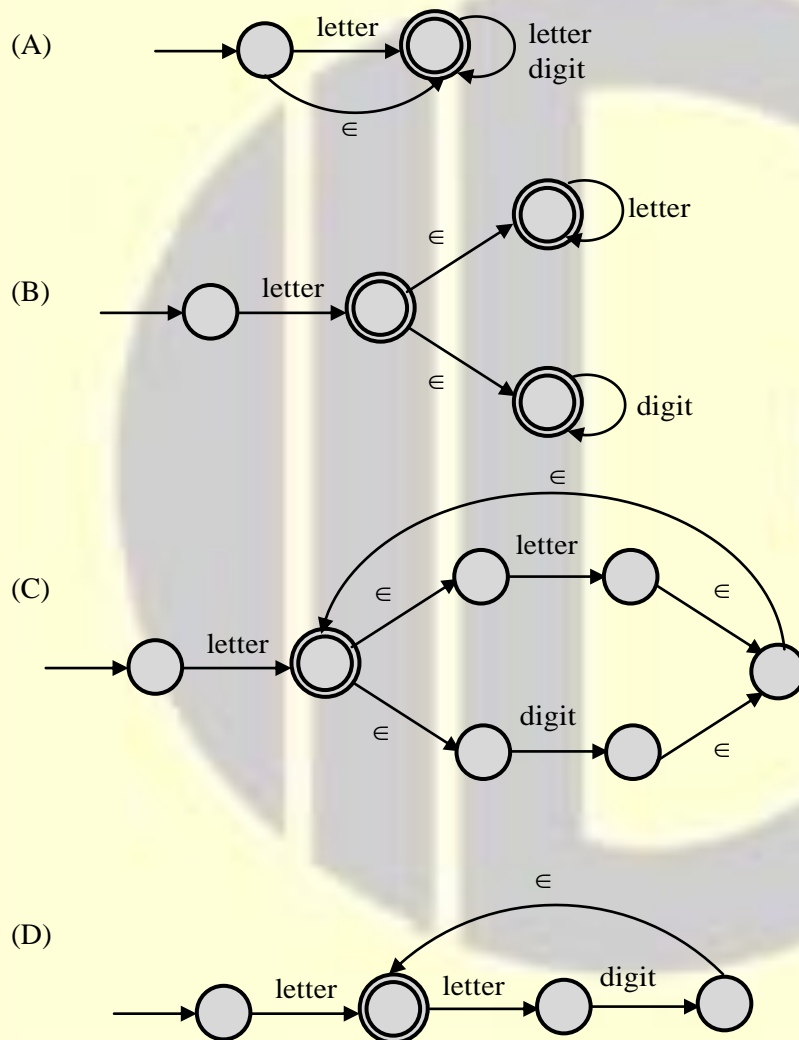

**Answer:** (C)

[Click here to watch video explanation](#)



10. An algorithm has to store several keys generated by an adversary in a hash table. The adversary is malicious who tries to maximize the number of collisions. Let  $k$  be the number of keys,  $m$  be the number of slots in the hash table, and  $k > m$ .

Which one of the following is the best hashing strategy to counteract the adversary?

- (A) Division method, i.e., use the hash function  $h(k) = k \bmod m$ .
- (B) Multiplication method, i.e., use the hash function  $h(k) = \lfloor m(kA - \lfloor kA \rfloor) \rfloor$ , where  $A$  is a carefully chosen constant.
- (C) Universal hashing method.
- (D) If  $k$  is a prime number, use Division method. Otherwise, use Multiplication method.

**Answer:** (C)

[Click here to watch video explanation](#)

11. The output of a 2-input multiplexer is connected back to one of its inputs as shown in the figure.

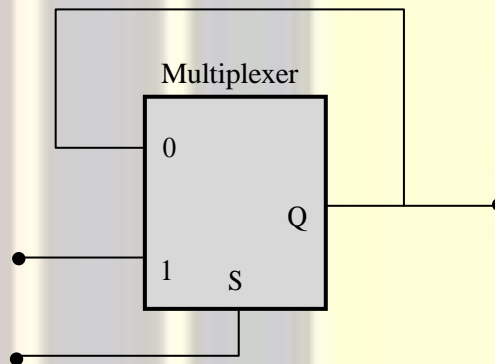

Match the functional equivalence of this circuit to one of the following options.

- (A) D Flip-flop
- (B) D Latch
- (C) Half-adder
- (D) Demultiplexer

**Answer:** (B)

[Click here to watch video explanation](#)

12. Which one or more of the following need to be saved on a context switch from one thread (T1) of a process to another thread (T2) of the same process?

- (A) Page table base register
- (B) Stack pointer
- (C) Program counter
- (D) General purpose registers

**Answer:** (B, C, D)

[Click here to watch video explanation](#)

13. Which one or more of the following options guarantee that a computer system will transition from user mode to kernel mode?
- (A) Function Call (B) malloc Call  
(C) Page Fault (D) System Call

**Answer:** (C, D)

[Click here to watch video explanation](#)

14. Which of the following statements is/are CORRECT?
- (A) The intersection of two regular languages is regular.  
(B) The intersection of two context-free languages is context-free.  
(C) The intersection of two recursive languages is recursive.  
(D) The intersection of two recursively enumerable languages is recursively enumerable.

**Answer:** (A, C, D)

[Click here to watch video explanation](#)

15. Which of the following statements is/are INCORRECT about the OSPF (Open Shortest Path First) routing protocol used in the Internet?
- (A) OSPF implements Bellman-Ford algorithm to find shortest paths.  
(B) OSPF uses Dijkstra's shortest path algorithm to implement least-cost path routing.  
(C) OSPF is used as an inter-domain routing protocol.  
(D) OSPF implements hierarchical routing.

**Answer:** (A, C)

[Click here to watch video explanation](#)

16. Geetha has a conjecture about integers, which is of the form

$$\forall x(P(x) \Rightarrow \exists yQ(x, y)),$$

where P is a statement about integers, and Q is a statement about pairs of integers. Which of the following (one or more) option(s) would imply Geetha's conjecture?

- (A)  $\exists x(P(x) \wedge \forall yQ(x, y))$  (B)  $\forall x\forall yQ(x, y)$   
(C)  $\exists y\forall x(P(x) \Rightarrow Q(x, y))$  (D)  $\exists x(P(x) \wedge \exists yQ(x, y))$

**Answer:** (B, C)

[Click here to watch video explanation](#)

17. Which one or more of the following CPU scheduling algorithms can potentially cause starvation?

- (A) First-in First-Out (B) Round Robin  
(C) Priority Scheduling (D) Shortest Job First

**Answer: (C, D)**

[Click here to watch video explanation](#)

18. Let  $f(x) = x^3 + 15x^2 - 33x - 36$  be a real-valued function.

Which of the following statements is/are TRUE?

- (A)  $f(x)$  does not have a local maximum (B)  $f(x)$  has a local maximum.  
(C)  $f(x)$  does not have a local minimum (D)  $f(x)$  has a local minimum.

**Answer: (B, D)**

[Click here to watch video explanation](#)

19. Let  $f$  and  $g$  be functions of natural numbers given by  $f(n) = n$  and  $g(n) = n^2$ . Which of the following statements is/are TRUE?

- (A)  $f \in O(g)$  (B)  $f \in \Omega(g)$  (C)  $f \in o(g)$  (D)  $f \in \Theta(g)$

**Answer: (A, C)**

[Click here to watch video explanation](#)

20. Let  $A$  be the adjacency matrix of the graph with vertices  $\{1, 2, 3, 4, 5\}$ .

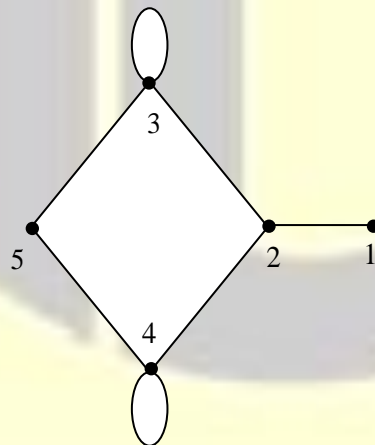

Let  $\lambda_1, \lambda_2, \lambda_3, \lambda_4$  and  $\lambda_5$  be the five eigenvalues of  $A$ . Note that these eigenvalues need not be distinct.

The value of  $\lambda_1 + \lambda_2 + \lambda_3 + \lambda_4 + \lambda_5 =$  \_\_\_\_\_.

**Answer: (2)**

[Click here to watch video explanation](#)

21. The value of the definite integral

$$\int_{-3}^3 \int_{-2}^2 \int_{-1}^1 (4x^2y - z^3) dz dy dx$$

Is \_\_\_\_\_ . (Rounded off to the nearest integer)

**Answer:** (0)

[Click here to watch video explanation](#)

22. A particular number is written as 132 in radix-4 representation. The same number in radix-5 representation is \_\_\_\_\_.

**Answer:** (110)

[Click here to watch video explanation](#)

23. Consider a 3-stage pipelined processor having a delay of 10 ns (nanoseconds), 20 ns, and 14 ns, for the first, second, and the third stages, respectively. Assume that there is no other delay and the processor does not suffer from any pipeline hazards. Also assume that one instruction is fetched every cycle.

The total execution time for executing 100 instructions on this processor is \_\_\_\_\_ ns.

**Answer:** (2040)

[Click here to watch video explanation](#)

24. A keyboard connected to a computer is used at a rate of 1 keystroke per second. The computer system polls the keyboard every 10 ms (milli seconds) to check for a keystroke and consumes 100  $\mu$ s (micro seconds) for each poll. If it is determined after polling that a key has been pressed, the system consumes an additional 200  $\mu$ s to process the keystroke. Let  $T_1$  denote the fraction of a second spent in polling and processing a keystroke.

In an alternative implementation, the system uses interrupts instead of polling. An interrupt is raised for every keystroke. It takes a total of 1 ms for servicing an interrupt and processing a keystroke. Let  $T_2$  denote the fraction of a second spent in servicing the interrupt and processing a keystroke.

The ratio  $\frac{T_1}{T_2}$  is \_\_\_\_\_ . (Rounded off to one decimal place)

**Answer:** (10.2)

[Click here to watch video explanation](#)

25. The integer value printed by the ANSI-C program given below is .

```
#include<stdio.h>

int funcp(){
    static int x = 1;
    x++;
    return x;
}

int main(){
    int x,y;
    x = funcp();
    y = funcp()+x; printf("%d\n", (x+y));
    return 0;
}
```

**Answer: (7)**

[Click here to watch video explanation](#)

**Q. No. 26-55 Carry Two Mark Each**

26. Consider the following program:

<pre>int main( ) {     f1( );     f2( );     f3( );     return (0); }</pre>	<pre>int main( ) {     return (1); }</pre>	<pre>int f2 (in X) {     fe( );     if (X == 1)         return f1( );     else         return (X * f2(X - 1)); }</pre>	<pre>int f3( ) {     return (5); }</pre>
---	--	--	--

Which one of the following options represents the activation tree corresponding to the main function?

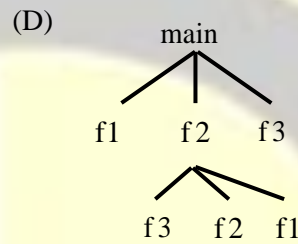
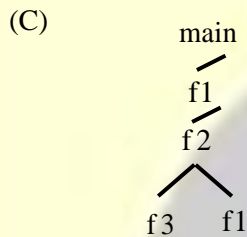
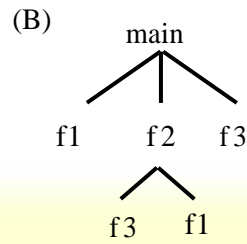
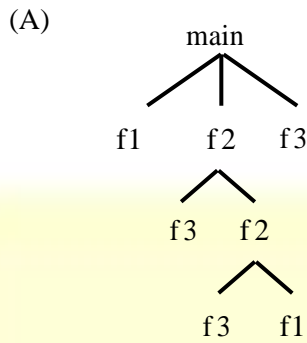

**Answer: (A)**

[Click here to watch video explanation](#)

27. Consider the control flow graph shown.

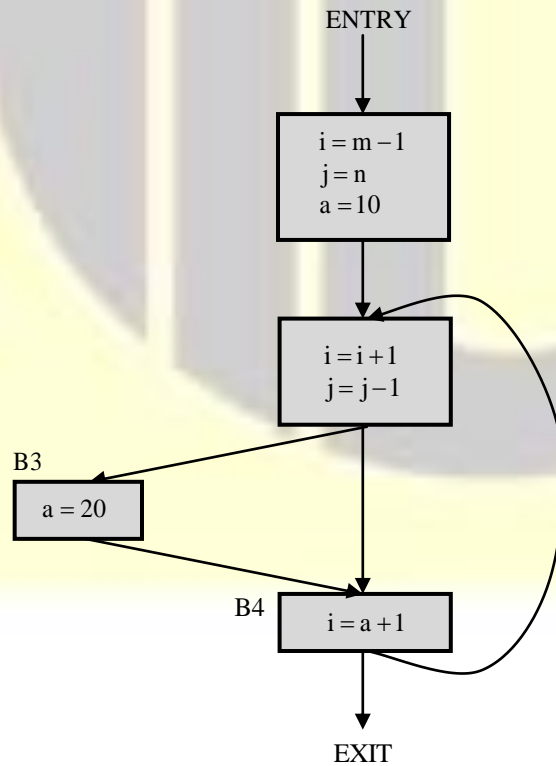

Which one of the following choices correctly lists the set of live variables at the exit point of each basic block?

- (A) B1: {}, B2: {a}, B3: {a}, B4: {a}
- (B) B1: {i, j}, B2: {a}, B3: {a}, B4: {i}
- (C) B1: {a, i, j}, B2: {a, i, j}, B3: {a, i}, B4: {a}
- (D) B1: {a, i, j}, B2: {a, j}, B3: {a, j}, B4: {a, i, j}

**Answer: (D)**

[Click here to watch video explanation](#)

28. Consider the two functions incr and decr shown below.

```

incr ( ) {
    wait (s);
    X = X + 1;
    signal (s);
}
    
```

```

decr ( ) {
    wait (s);
    X = X - 1;
    signal (s);
}
    
```

There are 5 threads each invoking incr once, and 3 threads each invoking decr once, on the same shared variable X. The initial value of X is 10.

Suppose there are two implementations of the semaphore s, as follows:

I-1: s is a binary semaphore initialized to 1.

I-2: s is a counting semaphore initialized to 2.

Let V1, V2 be the values of X at the end of execution of all the threads with implementations I-1, I-2, respectively.

Which one of the following choices corresponds to the minimum possible values of V1, V2, respectively?

- (A) 15, 7
- (B) 7, 7
- (C) 12, 7
- (D) 12, 8

**Answer: (C)**

[Click here to watch video explanation](#)

29. Consider the context-free grammar G below

$S \rightarrow aSbX$

$X \rightarrow aX | Xb | a | b,$

where S and X are non-terminals, and a and b are terminal symbols. The starting non-terminal is S.

Which one of the following statements is CORRECT?

- (A) The language generated by G is  $(a + b)^*$
- (B) The language generated by G is  $a^*(a + b)b^*$
- (C) The language generated by G is  $a*b^*(a + b)$
- (D) The language generated by G is not a regular language

**Answer:** (B)

[Click here to watch video explanation](#)

30. Consider the pushdown automaton (PDA) P below, which runs on the input alphabet  $\{a, b\}$ , has stack alphabet  $\{\perp, A\}$ , and has three states  $\{s, p, q\}$ , with  $s$  being the start state. A transition from state  $u$  to state  $v$ , labeled  $c/X/\gamma$ , where  $c$  is an input symbol or  $\epsilon$ ,  $X$  is a stack symbol, and  $\gamma$  is a string of stack symbols, represents the fact that in state  $u$ , the PDA can read  $c$  from the input, with  $X$  on the top of its stack, pop  $X$  from the stack, push in the string  $\gamma$  on the stack, and go to state  $v$ . In the initial configuration, the stack has only the symbol  $\perp$  in it. The PDA accepts by empty stack.

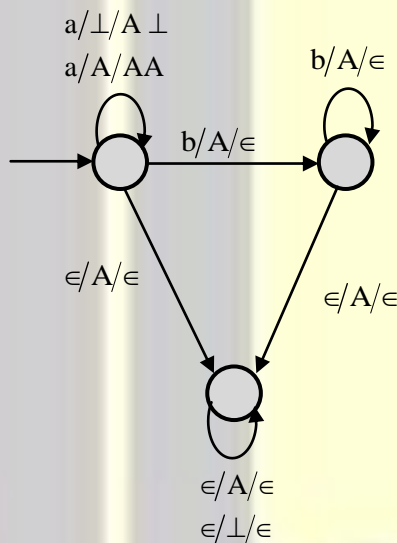

Which one of the following options correctly describes the language accepted by P ?

- (A)  $\{a^m b^n \mid 1 \leq m \text{ and } n < m\}$
- (B)  $\{a^m b^n \mid 0 \leq n \leq m\}$
- (C)  $\{a^m b^n \mid 0 \leq m \text{ and } 0 \leq n\}$
- (D)  $\{a^m \mid 0 \leq m\} \cup \{b^n \mid 0 \leq n\}$

**Answer:** (A)

[Click here to watch video explanation](#)





## *GATE REFRESHER COURSE*

Computer Science Engineering

**GATEFORUM** Pioneers in Digital courses for GATE since 2008 offers **GATE refresher course** giving you access to video solutions for previous 11 years GATE questions and Topic-wise formula Compendium (Handbook).

**Enroll now and get 20% discount use  
Promo Code **GATEPAPERS****

**For more details visit [gateforumonline.com](http://gateforumonline.com)**

31. Consider the given C-code and its corresponding assembly code, with a few operands U1–U4 being unknown. Some useful information as well as the semantics of each unique assembly instruction is annotated as inline comments in the code. The memory is byte-addressable.

```
// C-code
```

```
int a[10], b[10], i;
// int is 32-bit
for (i=0; i<10; i++)
    a[i]=b[i]*8;
```

```
;assembly y-code (; indicates comments)
```

```
;r1-r5 are 32-bit integer registers
```

```
; initialize r1=0, r2=10
```

```
; initialize r3, r4 with base address of a,b
```

```
L01: jeq r1, r2, end ;if (r1==r2) goto end
```

```
L02: lw r5, 0(r4) ;r5<-Memory [r4+0]
```

```
L03: shl r5, r5, U1 ;r5<-r5<<U1
```

```
L04: sw r5, 0(r3) ;Memory[r3+0]<-r5
```

```
L05: add r3, r3, U2 ;r3<-r3+U2
```

```
L06: add r4, r4, U3 ;r3<-r3+U2
```

```
L07: add r1, r1, 1
```

```
L08: jump U4 ;goto U4
```

```
L09: end
```

Which one of the following options is a CORRECT replacement for operands in the position (U1, U2, U3, U4) in the above assembly code?

- (A) (8, 4, 1, L02)                                  (B) (3, 4, 4, L01)  
(C) (8, 1, 1, L02)                                  (D) (3, 1, 1, L01)

**Answer: (B)**

**[Click here to watch video explanation](#)**



33. Consider a sequential digital circuit consisting of T flip-flops and D flip-flops as shown in the figure. CLKIN is the clock input to the circuit. At the beginning, Q1, Q2 and Q3 have values 0, 1 and 1, respectively.

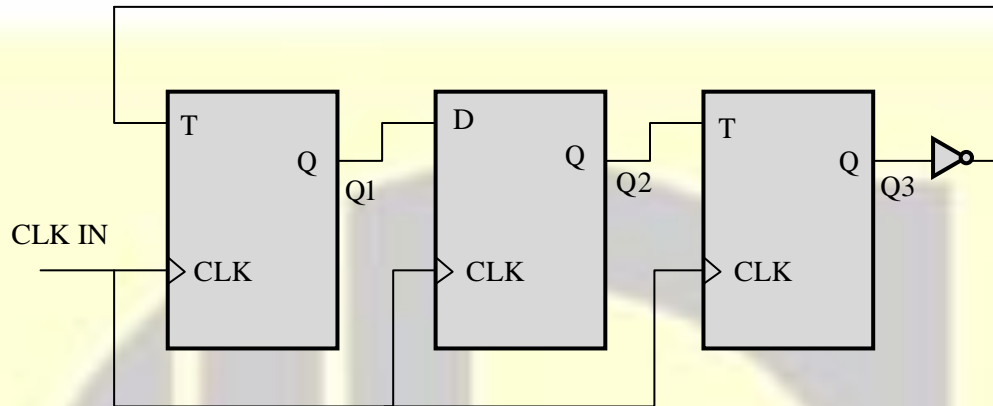

Which one of the given values of (Q1, Q2, Q3) can NEVER be obtained with this digital circuit?

- (A) (0, 0, 1)      (B) (1, 0, 0)      (C) (1, 0, 1)      (D) (1, 1, 1)

**Answer: (A)**

[Click here to watch video explanation](#)

34. A Boolean digital circuit is composed using two 4-input multiplexers (M1 and M2) and one 2-input multiplexer (M3) as shown in the figure. X0–X7 are the inputs of the multiplexers M1 and M2 and could be connected to either 0 or 1. The select lines of the multiplexers are connected to Boolean variables A, B and C as shown.

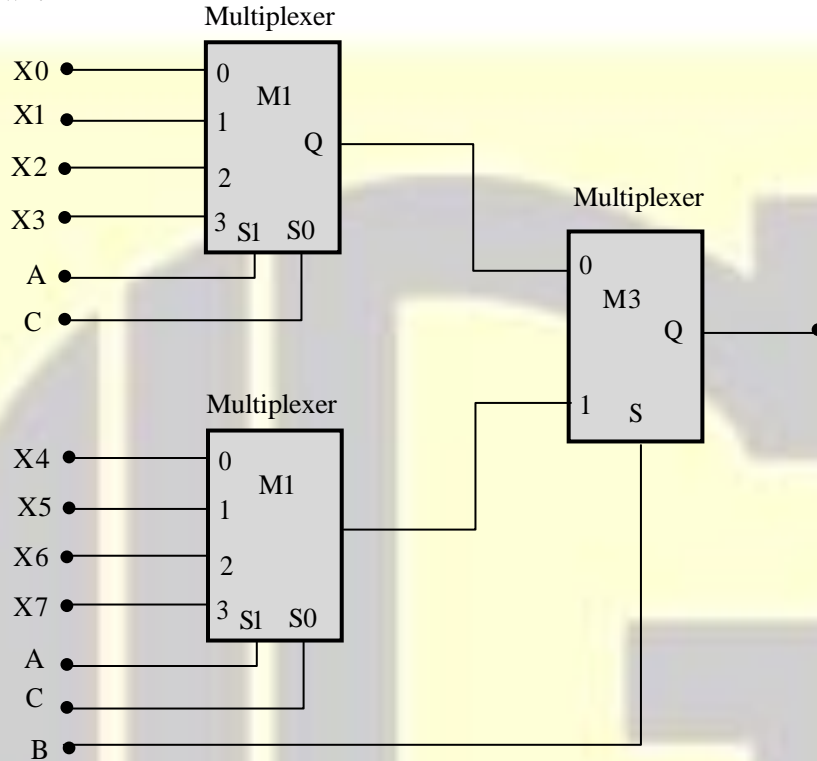

Which one of the following set of values of (X0, X1, X2, X3, X4, X5, X6, X7) will realise the Boolean function  $A + A.C + A.B.C$ ?

- (A) (1, 1, 0, 0, 1, 1, 1, 0)                      (B) (1, 1, 0, 0, 1, 1, 0, 1)  
(C) (1, 1, 0, 1, 1, 1, 0, 0)                      (D) (0, 0, 1, 1, 0, 1, 1, 1)

**Answer:** (C)

[Click here to watch video explanation](#)

35. Consider the IEEE-754 single precision floating point numbers

$$P = 0 \times C1800000 \text{ and } Q = 0 \times 3F5CEF4.$$

Which one of the following corresponds to the product of these numbers (i.e.,  $P \times Q$ ), represented in the IEEE-754 single precision format?

- (A)  $0 \times 404C2EF4$                       (B)  $0 \times 405C2EF4$   
(C)  $0 \times C15C2EF4$                       (D)  $0 \times C14C2EF4$

**Answer:** (C)

[Click here to watch video explanation](#)

36. Let A be a priority queue for maintaining a set of elements. Suppose A is implemented using a max-heap data structure. The operation EXTRACT-MAX(A) extracts and deletes the maximum element from A. The operation Insert(A,key) inserts a new element key in A. The properties of a max-heap are preserved at the end of each of these operations.

When A contains n elements, which one of the following statements about the worst case running time of these two operations is TRUE?

- (A) Both Extract-Max(A) and Insert(A,key) run in  $O(1)$ .
- (B) Both Extract-Max(A) and Insert(A,key) run in  $O(\log(n))$ .
- (C) Extract-Max(A) runs in  $O(1)$  whereas Insert(A,key) runs in  $O(n)$ .
- (D) Extract-Max(A) runs in  $O(1)$  whereas Insert(A,key) runs in  $O(\log(n))$ .

**Answer:** (B)

[Click here to watch video explanation](#)

37. Consider the C function foo and the binary tree shown.

```
typedef struct node {
    int val;
    struct node *left, *right;
} node;
```

```
int foo(node *p) {
    int retval; 3
    if (p == NULL)
        return 0;
    else {
        retval = p->val + foo(p->left) + foo(p->right);
        printf("%d ", retval);
        return retval;
    }
}
```

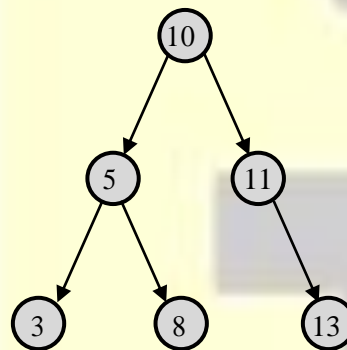

When foo is called with a pointer to the root node of the given binary tree, what will it print?

- (A) 3 8 5 13 11 10
- (B) 3 5 8 10 11 13
- (C) 3 8 16 13 24 50
- (D) 3 16 8 50 24 13

**Answer:** (C)

[Click here to watch video explanation](#)

38. Let  $U = \{1, 2, \dots, n\}$ , where  $n$  is a large positive integer greater than 1000. Let  $k$  be a positive integer less than  $n$ . Let  $A, B$  be subsets of  $U$  with  $|A|=|B|=k$  and  $A \cap B = \emptyset$ . We say that a permutation of  $U$  separates  $A$  from  $B$  if one of the following is true.

- All members of  $A$  appear in the permutation before any of the members of  $B$ .

- All members of  $B$  appear in the permutation before any of the members of  $A$ . How many permutations of  $U$  separate  $A$  from  $B$ ?

- (A)  $n!$  (B)  $\binom{n}{2k}(n-2k)!$   
 (C)  $\binom{n}{2k}(n-2k)!(k!)^2$  (D)  $2\binom{n}{2k}(n-2k)!(k!)^2$

**Answer: (D)**

[Click here to watch video explanation](#)

39. Let  $f: A \rightarrow B$  be an onto (or surjective) function, where  $A$  and  $B$  are nonempty sets. Define an equivalence relation  $\sim$  on the set  $A$  as

$$a_1 \sim a_2 \text{ if } f(a_1) = f(a_2),$$

Where  $a_1, a_2 \in A$ . Let  $\varepsilon = \{[x] : x \in A\}$  be the set of all the equivalence classes under  $\sim$ . Define a new mapping  $F: \varepsilon \rightarrow B$  as

$$F([x]) = f(x), \text{ for all the equivalence classes } [x] \text{ in } \varepsilon.$$

Which of the following statements is/are TRUE?

- (A)  $F$  is NOT well-defined (B)  $F$  is an onto (or surjective) function.  
 (C)  $F$  is a one-to-one (or injective) function. (D)  $F$  is a bijective function.

**Answer: (B, C, D)**

[Click here to watch video explanation](#)

40. Suppose you are asked to design a new reliable byte-stream transport protocol like TCP. This protocol, named myTCP, runs over a 100 Mbps network with Round Trip Time of 150 milliseconds and the maximum segment lifetime of 2 minutes.

Which of the following is/are valid lengths of the Sequence Number field in the myTCP header?

- (A) 30 bits (B) 32 bits (C) 34 bits (D) 36 bits

**Answer: (B, C, D)**

[Click here to watch video explanation](#)

41. Let  $X$  be a set and  $2^X$  denote the powerset of  $X$ .  
Define a binary operation  $\Delta$  on  $2^X$  as follows:  
$$A\Delta B = (A - B) \cup (B - A)$$
  
Let  $H = (2^X, \Delta)$ . What of the following statements about  $H$  is/are correct?
- (A)  $H$  is a group
  - (B) Every element in  $H$  has an inverse, but  $H$  is NOT a group
  - (C) For every  $A \in 2^X$ , the inverse of  $A$  is the complement of  $A$ .
  - (D) For every  $A \in 2^X$ , the inverse of  $A$  is  $A$ .

**Answer:** (A, D)

[Click here to watch video explanation](#)

42. Suppose in a web browser, you click on the `www.gate-2023.in` URL. The browser cache is empty. The IP address for this URL is not cached in your local host, so a DNS lookup is triggered (by the local DNS server deployed on your local host) over the 3-tier DNS hierarchy in an iterative mode. No resource records are cached anywhere across all DNS servers.
- Let RTT denote the round trip time between your local host and DNS servers in the DNS hierarchy. The round trip time between the local host and the web server hosting `www.gate-2023.in` is also equal to RTT. The HTML file associated with the URL is small enough to have negligible transmission time and negligible rendering time by your web browser, which references 10 equally small objects on the same web server.
- Which of the following statements is/are CORRECT about the minimum elapsed time between clicking on the URL and your browser fully rendering it?
- (A) 7 RTTs, in case of non-persistent HTTP with 5 parallel TCP connections.
  - (B) 5 RTTs, in case of persistent HTTP with pipelining.
  - (C) 9 RTTs, in case of non-persistent HTTP with 5 parallel TCP connections.
  - (D) 6 RTTs, in case of persistent HTTP with pipelining.

**Answer:** (C, D)

[Click here to watch video explanation](#)



43. Consider a random experiment where two fair coins are tossed. Let A be the event that denotes HEAD on both the throws, B be the event that denotes HEAD on the first throw, and C be the event that denotes HEAD on the second throw. Which of the following statements is/are TRUE?
- (A) A and B are independent. (B) A and C are independent.  
(C) B and C are independent. (D)  $\text{Prob}(B|C) = \text{Prob}(B)$

**Answer:** (C, D)

[Click here to watch video explanation](#)

44. Consider functions Function 1 and Function 2 expressed in pseudocode as follows:

```
Function _1
  while n > 1 do
    for x = 1 to n do
      x = x + 1;
    end for
    n = ⌊n/2⌋;
  end while
```

```
Function _2
  for x = 1 to 100 * n do
    x = x + 1;
  end for
```

Let  $f_1(n)$  and  $f_2(n)$  denote the number of times the statement “ $x = x + 1$ ” is executed in Function 1 and Function 2, respectively.

Which of the following statements is/are TRUE?

- (A)  $f_1(n) \Theta(f_2(n))$  (B)  $f_1(n) \in o(f_2(n))$   
(C)  $f_1(n) \in \omega(f_2(n))$  (D)  $f_1(n) \in O(n)$

**Answer:** (A, D)

[Click here to watch video explanation](#)

45. Let G be a simple, finite, undirected graph with vertex set  $\{v_1, \dots, v_n\}$ . Let  $\Delta(G)$  denote the maximum degree of G and let  $N = \{1, 2, \dots\}$  denote the set of all possible colors. Color the vertices of G using the following greedy strategy:

for  $i = 1, \dots, n$

color( $v_i$ )  $\leftarrow \min\{j \in N : \text{no neighbour of } v_i \text{ is colored } j\}$

Which of the following statements is/are TRUE?

- (A) This procedure results in a proper vertex coloring of G.
- (B) The number of colors used is at most  $\Delta(G)+1$
- (C) The number of colors used is at most  $\Delta(G)$ .
- (D) The number of colors used is equal to the chromatic number of G.

**Answer: (A, B)**

[Click here to watch video explanation](#)

46. Let  $U = \{1, 2, 3\}$ . Let  $2^U$  denote the powerset of U. Consider an undirected graph G whose vertex set is  $2^U$ . For any  $A, B \in 2^U$ ,  $(A, B)$  is an edge in G if and only if (i)  $A \neq B$ , and (ii) either  $A \subseteq B$  or  $B \subseteq A$ . For any vertex A in G, the set of all possible orderings in which vertices of G can be visited in a Breadth First Search (BFS) starting from A is denoted by  $B(A)$ . If  $\theta$  denoted the empty set, then the cardinality of  $B(\theta)$  is \_\_\_\_\_.

**Answer: (5040)**

[Click here to watch video explanation](#)

47. Consider the following two-dimensional array D in the C programming language, which is stored in row-major order:

```
int D[128][128];
```

Demand paging is used for allocating memory and each physical page frame holds 512 elements of the array D. The Least Recently Used (LRU) page-replacement policy is used by the operating system. A total of 30 physical page frames are allocated to a process which executes the following code snippet:

```
for (int i = 0; i < 128; i++)
    for (int j = 0; j < 128; j++)
        D[j][i] *= 10;
```

The number of page faults generated during the execution of this code snippet is \_\_\_\_\_.

**Answer: (4096)**

[Click here to watch video explanation](#)

48. Consider a computer system with 57-bit virtual addressing using multi-level tree-structured page tables with L levels for virtual to physical address translation. The page size is 4 KB (1 KB = 1024 B) and a page table entry at any of the levels occupies 8 bytes.

The value of L is \_\_\_\_\_.

**Answer: (5)**

[Click here to watch video explanation](#)

49. Consider a sequence  $a$  of elements  $a_0 = 1, a_1 = 5, a_2 = 7, a_3 = 8, a_4 = 9,$  and  $a_5 = 2$ . The following operations are performed on a stack  $S$  and a queue  $Q$ , both of which are initially empty.
- I: push the elements of  $a$  from  $a_0$  to  $a_5$  in that order into  $S$ .
- II: enqueue the elements of  $a$  from  $a_0$  to  $a_5$  in that order into  $Q$ .
- III: pop an element from  $S$ .
- IV: dequeue an element from  $Q$ . V: pop an element from  $S$ .
- VI: dequeue an element from  $Q$ .
- VII: dequeue an element from  $Q$  and push the same element into  $S$ .
- VIII: Repeat operation VII three times.
- IX: pop an element from  $S$ .
- X: pop an element from  $S$ .
- The top element of  $S$  after executing the above operations is \_\_\_\_\_ .

**Answer: (8)**

[Click here to watch video explanation](#)

50. Consider the syntax directed translation given by the following grammar and semantic rules. Here  $N, I, F$  and  $B$  are non-terminals.  $N$  is the starting non-terminal, and  $\#, 0$  and  $1$  are lexical tokens corresponding to input letters “#”, “0” and “1”, respectively.  $X.val$  denotes the synthesized attribute (a numeric value) associated with a non-terminal  $X$ .  $I_1$  and  $F_1$  denote occurrences of  $I$  and  $F$  on the right hand side of a production, respectively. For the tokens  $0$  and  $1, 0.val = 0$  and  $1.val = 1$ .

$$\begin{array}{ll}
 N \rightarrow I\#F & N.val = I.val + F.val \\
 I \rightarrow I_1B & I.val = 2(I_1.val) + B.val \\
 I \rightarrow B & I.val = B.val \\
 F \rightarrow BF_1 & F.val = \frac{1}{2}(B.val + F_1.val) \\
 F \rightarrow B & F.val = \frac{1}{2}B.val \\
 B \rightarrow 0 & B.val = 0.val \\
 B \rightarrow 1 & B.val = 1.val
 \end{array}$$

The value computed by the translation scheme for the input string  $10 \# 011$  is \_\_\_\_\_ . (Rounded off to three decimal places)

**Answer: (2.375)**

[Click here to watch video explanation](#)

51. Consider the following table named Student in a relational database. The primary key of this table is rollNum.

Student

Roll Num	Name	Gender	Marks
1	Naman	M	62
2	Aliya	F	70
3	Aliya	F	80
4	James	M	82
5	Swati	F	65

The SQL query below is executed on this database.

```
SELECT *  
FROM Student  
WHERE gender = 'F' AND  
marks > 65;
```

The number of rows returned by the query is \_\_\_\_\_ .

**Answer: (2)**

[Click here to watch video explanation](#)

52. Consider a database of fixed-length records, stored as an ordered file. The database has 25,000 records, with each record being 100 bytes, of which the primary key occupies 15 bytes. The data file is block-aligned in that each data record is fully contained within a block. The database is indexed by a primary index file, which is also stored as a block-aligned ordered file. The figure below depicts this indexing scheme.

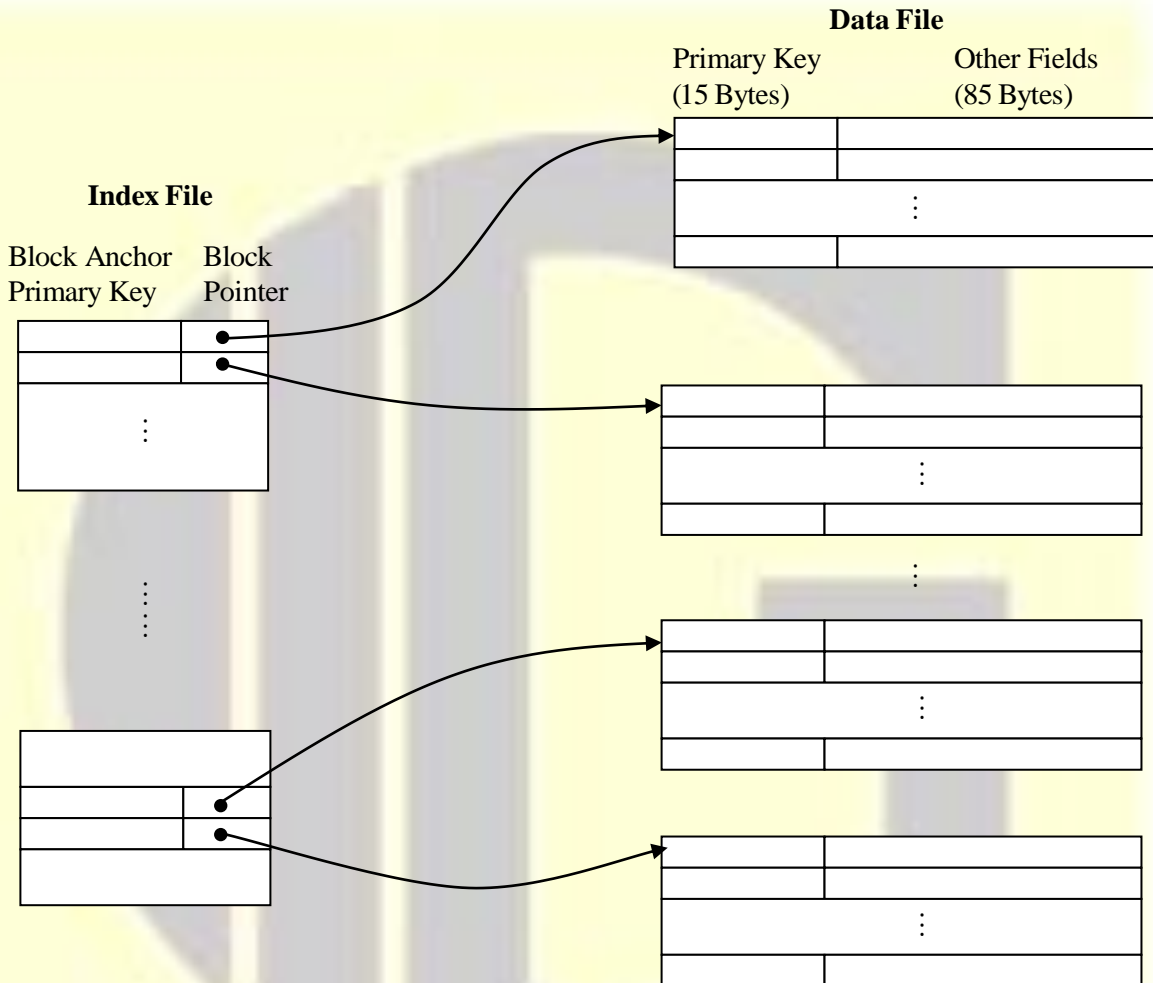

Suppose the block size of the file system is 1024 bytes, and a pointer to a block occupies 5 bytes. The system uses binary search on the index file to search for a record with a given key. You may assume that a binary search on an index file of  $b$  blocks takes  $\log_2 b$  block accesses in the worst case.

Given a key, the number of block accesses required to identify the block in the data file that may contain a record with the key, in the worst case, is \_\_\_\_\_.

**Answer: (6)**

[Click here to watch video explanation](#)

53. Consider the language L over the alphabet {0, 1}, given below:

$$L = \{\omega \in \{0,1\}^* \mid \omega \text{ does not contain three or more consecutive 1's}\}$$

The minimum number of states in a Deterministic Finite-State Automaton (DFA) for L is \_\_\_\_\_

**Answer: (4)**

[Click here to watch video explanation](#)

54. An 8-way set associative cache of size 64 KB (1 KB = 1024 bytes) is used in a system with 32-bit address. The address is sub-divided into TAG, INDEX, and BLOCK OFFSET.

The number of bits in the TAG is \_\_\_\_\_.

**Answer: (19)**

[Click here to watch video explanation](#)

55. The forwarding table of a router is shown below.

Subnet Number	Subnet Mask	Interface ID
200.150.0.0	255.255.0.0	1
200.150.64.0	255.255.224.0	2
200.150.68.0	255.255.255.0	3
200.150.68.64	255.255.255.224	4
Default		0

A packet addressed to a destination address 200.150.68.118 arrives at the router. It will be forwarded to the interface with ID \_\_\_\_\_.

**Answer: (3)**

[Click here to watch video explanation](#)





Follow us @



For more details visit [gateforumonline.com](http://gateforumonline.com)