



GATE PREVIOUS YEAR SOLVED PAPERS

**Mechanical Engineering
Previous Year Solved Papers**

GATEFORUM Pioneers in Digital courses for GATE since 2008 has long history of training students through innovative courses. Currently GATEFORUM offers a wide range of courses from eGATE, GATE Online, Gdrive to Online TarGATE. Since inception, we have trained more 3,00,000 students since inception.

For more details visit gateforumonline.com

GENERAL APTITUDE**Q. No. 1 - 5 Carry One Mark Each**

1. He did not manage to fix the car himself, so he in the garage.
(A) got it fixed (B) getting it fixed (C) gets fixed (D) got fixed

Answer: (A)

[Click here to watch video explanation](#)

2. Planting : Seed : : Raising : _____ (By word meaning)
(A) Child (B) Temperature (C) Height (D) Lift

Answer: (A)

[Click here to watch video explanation](#)

3. A certain country has 504 universities and 25951 colleges. These are categorised into Grades I, II, and III as shown in the given pie charts.

What is the percentage, correct to one decimal place, of higher education institutions (colleges and universities) that fall into Grade III?

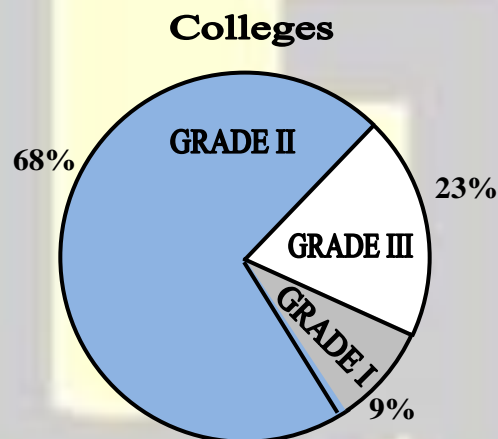
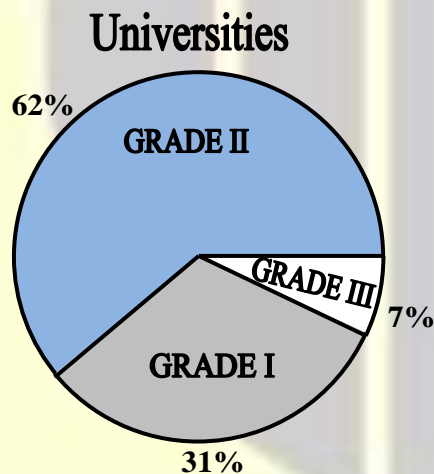

- (A) 22.7 (B) 23.7 (C) 15.0 (D) 66.8

Answer: (A)

[Click here to watch video explanation](#)

4. The minute-hand and second-hand of a clock cross each other times between 09:15:00 AM and 09:45:00 AM on a day.

- (A) 30 (B) 15 (C) 29 (D) 31

Answer: (A)

[Click here to watch video explanation](#)

5. The symbols \circ , $*$, \triangle , and \square are to be filled, one in each box, as shown below. The rules for filling in the four symbols are as follows.

1. Every row and every column must contain each of the four symbols.
2. Every 2×2 square delineated by bold lines must contain each of the four symbols.

Which symbol will occupy the box marked with '?' in the partially filled figure?

	?		\triangle
	\circ	*	
		\square	*
*		\triangle	\circ

Answer: (B)

[Click here to watch video explanation](#)

Q. No. 6-10 Carry Two Marks Each

6. In a recently held parent-teacher meeting, the teachers had very few complaints about Ravi. After all, Ravi was a hardworking and kind student. Incidentally, almost all of Ravi's friends at school were hardworking and kind too. But the teachers drew attention to Ravi's complete lack of interest in sports. The teachers believed that, along with some of his friends who showed similar disinterest in sports, Ravi needed to engage in some sports for his overall development.

Based only on the information provided above, which one of the following statements can be logically inferred with certainty?

- (A) All of Ravi's friends are hardworking and kind.
- (B) No one who is not a friend of Ravi is hardworking and kind.
- (C) None of Ravi's friends are interested in sports.
- (D) Some of Ravi's friends are hardworking and kind.

Answer: (A)

[Click here to watch video explanation](#)

7. Consider the following inequalities

$$p^2 - 4q < 4$$

$$3p + 2q < 6$$

Where p and q are positive integers. The value of $(p + q)$ is .

- (A) 2
- (B) 1
- (C) 3
- (D) 4

Answer: (A)

[Click here to watch video explanation](#)

MECHANICAL ENGINEERING**Q. No. 11 - 35 Carry One Mark Each**

11. A machine produces a defective component with a probability of 0.015. The number of defective components in a packed box containing 200 components produced by the machine follows a Poisson distribution. The mean and the variance of the distribution are
- (A) 3 and 3, respectively (B) $\sqrt{3}$ and $\sqrt{3}$, respectively
(C) 0.015 and 0.015, respectively (D) 3 and 9, respectively

Answer: (A)

[Click here to watch video explanation](#)

12. The figure shows the plot of a function over the interval $[-4, 4]$. Which one of the options given CORRECTLY identifies the function?

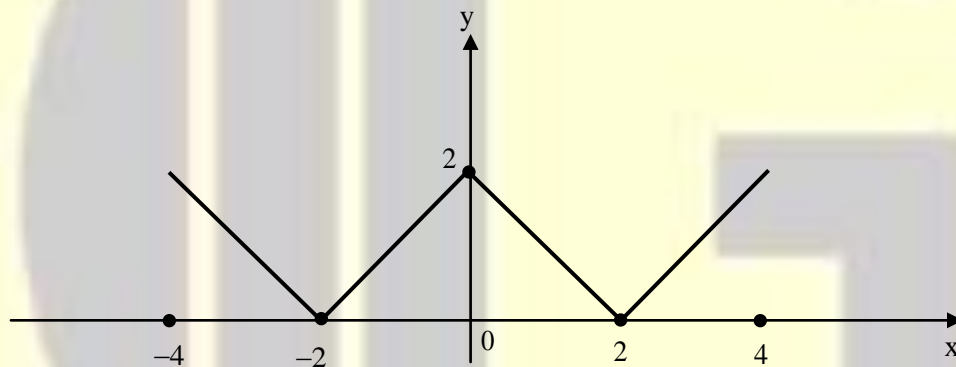

- (A) $|2-x|$ (B) $|2-|x||$ (C) $|2+|x||$ (D) $2-|x|$

Answer: (B)

[Click here to watch video explanation](#)

13. With reference to the Economic Order Quantity (EOQ) model, which one of the options given is correct?

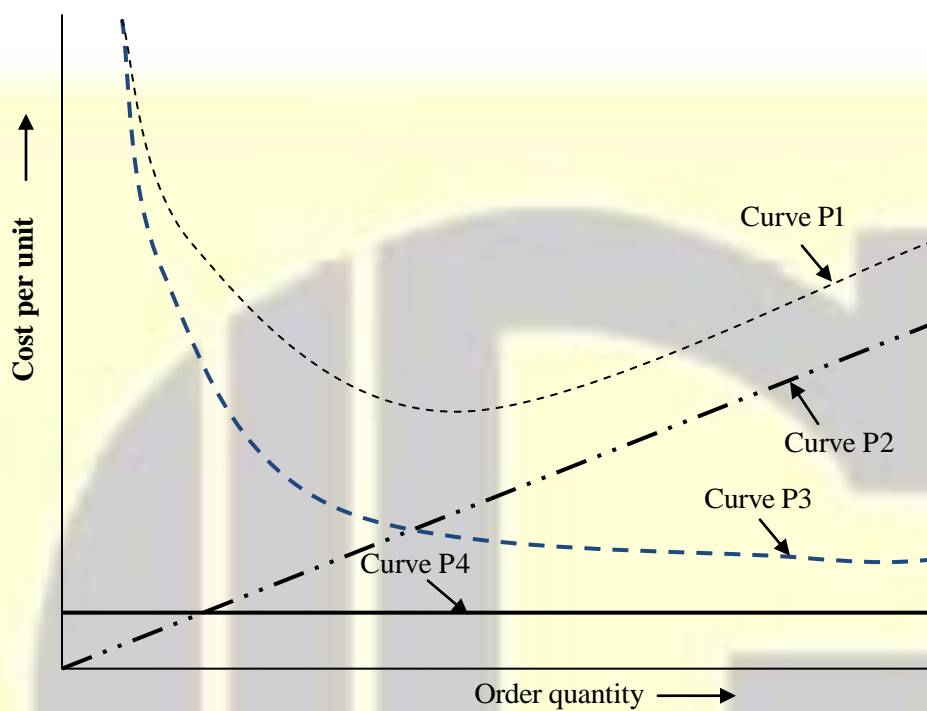

- (A) Curve P1: Total cost, Curve P2: Holding cost,
Curve P3: Setup cost, and Curve P4: Production cost.
- (B) Curve P1: Holding cost, Curve P2: Setup cost,
Curve P3: Production cost, and Curve P4: Total cost.
- (C) Curve P1: Production cost, Curve P2: Holding cost,
Curve P3: Total cost, and Curve P4: Setup cost.
- (D) Curve P1: Total cost, Curve P2: Production cost,
Curve P3: Holding cost, and Curve P4: Setup cost.

Answer: (A)

[Click here to watch video explanation](#)

14. Which one of the options given represents the feasible region of the linear programming model:

$$\text{Maximize } 45X_1 + 60X_2$$

$$X_1 \leq 45$$

$$X_2 \leq 50$$

$$10X_1 + 10X_2 \geq 600$$

$$25X_1 + 5X_2 \leq 750$$

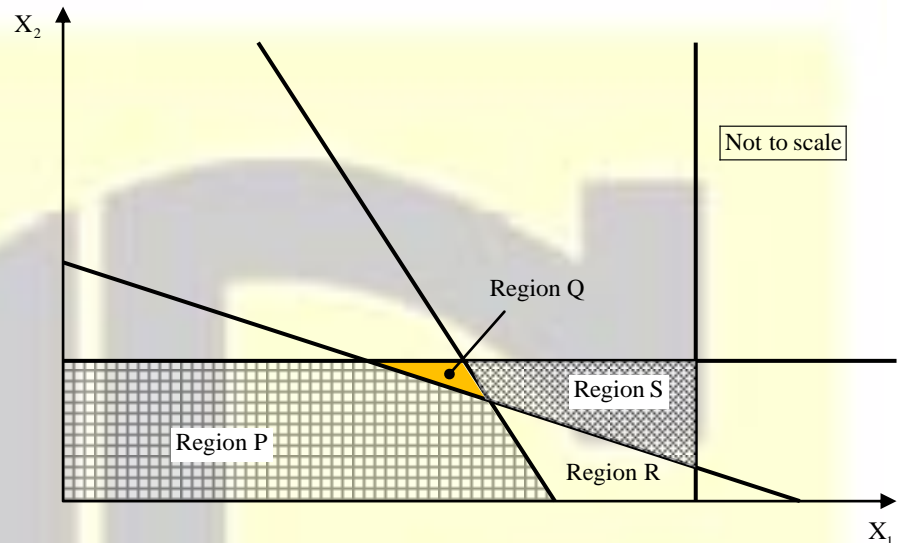

(A) Region P

(B) Region Q

(C) Region R

(D) Region S

Answer: (B)

[Click here to watch video explanation](#)

15. A cuboidal part has to be accurately positioned first, arresting six degrees of freedom and then clamped in a fixture, to be used for machining. Locating pins in the form of cylinders with hemi-spherical tips are to be placed on the fixture for positioning. Four different configurations of locating pins are proposed as shown. Which one of the options given is correct?

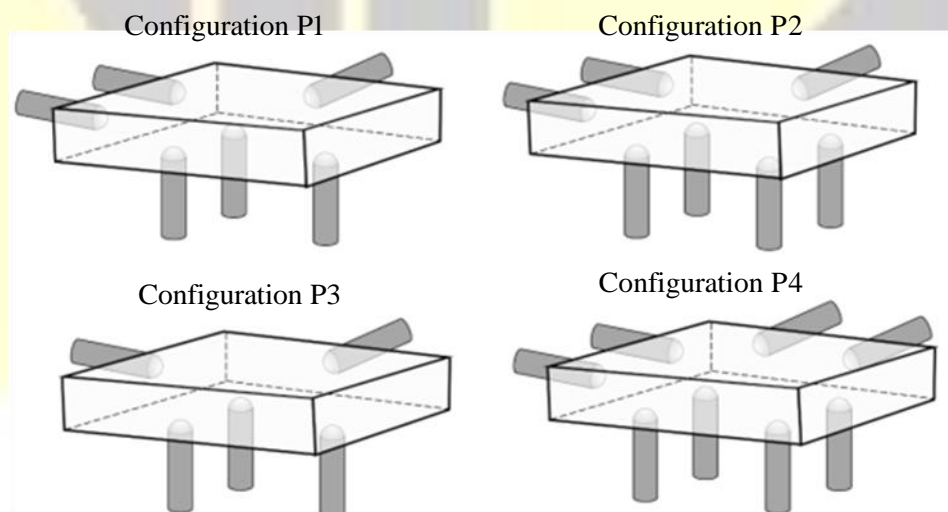

- (A) Configuration P1 arrests 6 degrees of freedom, while Configurations P2 and P4 are over-constrained and Configuration P3 is under-constrained.
- (B) Configuration P2 arrests 6 degrees of freedom, while Configurations P1 and P3 are over-constrained and Configuration P4 is under-constrained.
- (C) Configuration P3 arrests 6 degrees of freedom, while Configurations P2 and P4 are over-constrained and Configuration P1 is under-constrained.
- (D) Configuration P4 arrests 6 degrees of freedom, while Configurations P1 and P3 are over-constrained and Configuration P2 is under-constrained.

Answer: (A)

[Click here to watch video explanation](#)

16. The effective stiffness of a cantilever beam of length L and flexural rigidity EI subjected to a transverse tip load W is

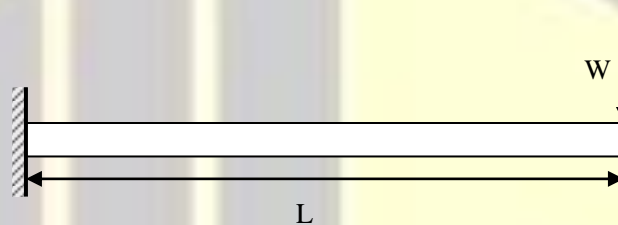

- (A) $\frac{3EI}{L^3}$
- (B) $\frac{2EI}{L^3}$
- (C) $\frac{L^3}{2EI}$
- (D) $\frac{L^3}{3EI}$

Answer: (A)

[Click here to watch video explanation](#)

17. The options show frames consisting of rigid bars connected by pin joints. Which one of the frames is non-rigid?

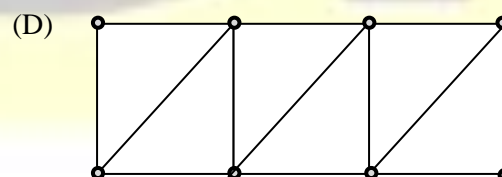
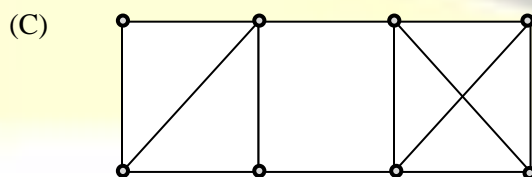
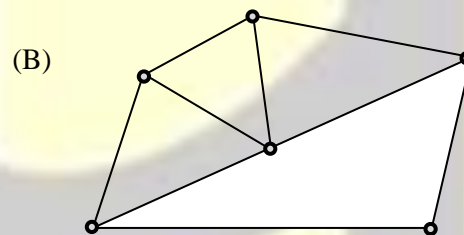
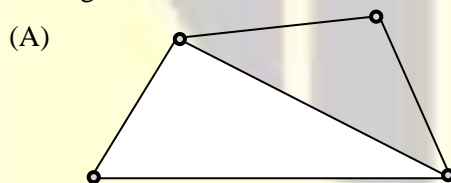

Answer: (C)

[Click here to watch video explanation](#)

18. The S-N curve from a fatigue test for steel is shown. Which one of the options gives the endurance limit?

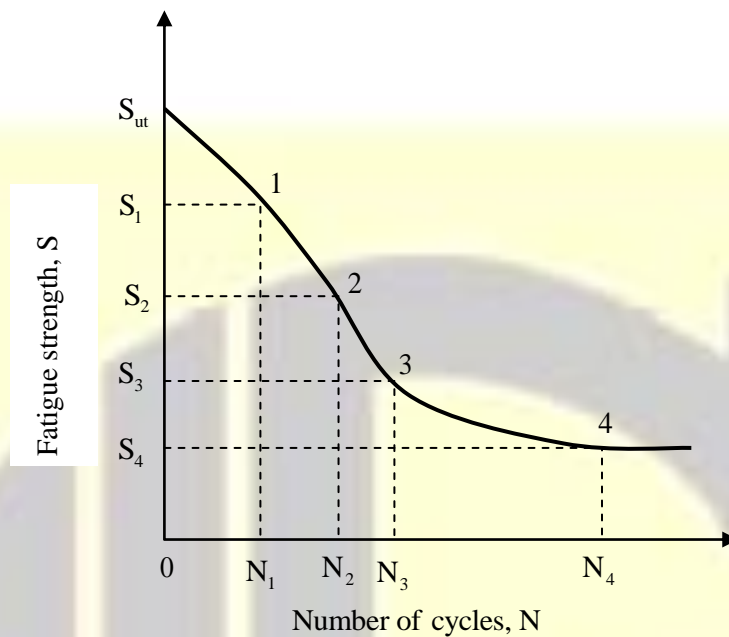

- (A) S_{ut} (B) S_2 (C) S_3 (D) S_4

Answer: (D)

[Click here to watch video explanation](#)

19. Air (density = 1.2 kg/m^3 , kinematic viscosity = $1.5 \times 10^{-5} \text{ m}^2/\text{s}$) flows over a flat plate with a free-stream velocity of 2 m/s. The wall shear stress at a location 15 mm from the leading edge is τ_w . What is the wall shear stress at a location 30 mm from the leading edge?

- (A) $\tau_w/2$ (B) $\sqrt{2}\tau_w$ (C) $2\tau_w$ (D) $\tau_w/\sqrt{2}$

Answer: (D)

[Click here to watch video explanation](#)

20. Consider an isentropic flow of air (ratio of specific heats = 1.4) through a duct as shown in the figure. The variations in the flow across the cross-section are negligible. The flow conditions at Location 1 are given as follows:

$$P_1 = 100 \text{ kPa}, \rho_1 = 1.2 \text{ kg/m}^3, u_1 = 400 \text{ m/s}$$

The duct cross-sectional area at Location 2 is given by $A_2 = 2A_1$, where A_1 denotes the duct cross-sectional area at Location 1. Which one of the given statements about the velocity u_2 and pressure P_2 at Location 2 is TRUE?

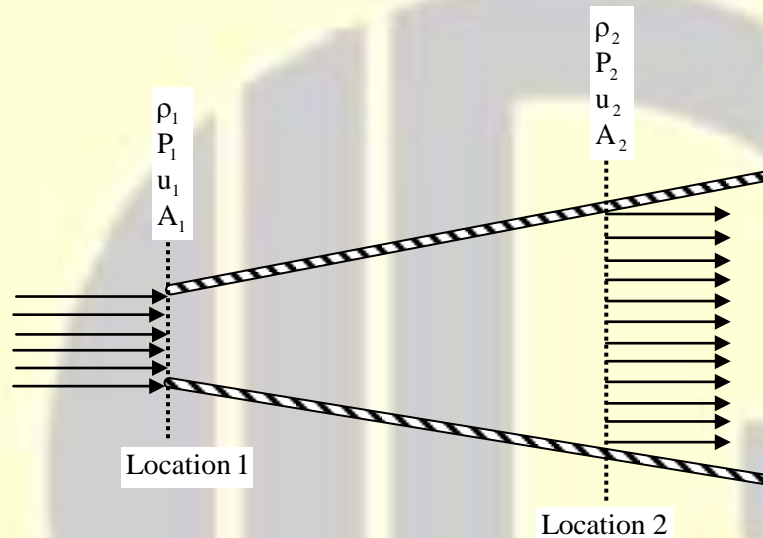

- (A) $u_2 < u_1, P_2 < P_1$ (B) $u_2 < u_1, P_2 > P_1$
(C) $u_2 > u_1, P_2 < P_1$ (D) $u_2 > u_1, P_2 > P_1$

Answer: (C)

[Click here to watch video explanation](#)

21. Consider incompressible laminar flow of a constant property Newtonian fluid in an isothermal circular tube. The flow is steady with fully-developed temperature and velocity profiles. The Nusselt number for this flow depends on

- (A) neither the Reynolds number nor the Prandtl number
(B) both the Reynolds and Prandtl numbers
(C) the Reynolds number but not the Prandtl number
(D) the Prandtl number but not the Reynolds number

Answer: (A)

[Click here to watch video explanation](#)

22. A heat engine extracts heat (Q_H) from a thermal reservoir at a temperature of 1000 K and rejects heat (Q_L) to a thermal reservoir at a temperature of 100 K, while producing work (W). Which one of the combinations of [Q_H, Q_L and W] given is allowed?
- (A) $Q_H = 2000 \text{ J}, Q_L = 500 \text{ J}, W = 1000 \text{ J}$ (B) $Q_H = 2000 \text{ J}, Q_L = 750 \text{ J}, W = 1250 \text{ J}$
 (C) $Q_H = 6000 \text{ J}, Q_L = 500 \text{ J}, W = 5500 \text{ J}$ (D) $Q_H = 6000 \text{ J}, Q_L = 600 \text{ J}, W = 5500 \text{ J}$

Answer: (B)

[Click here to watch video explanation](#)

23. Two surfaces P and Q are to be joined together. In which of the given joining operation(s), there is no melting of the two surfaces P and Q for creating the joint?
- (A) Arc welding (B) Brazing
 (C) Adhesive bonding (D) Spot welding

Answer: (B, C)

[Click here to watch video explanation](#)

24. A beam is undergoing pure bending as shown in the figure. The stress (σ)-strain (ϵ) curve for the material is also given. The yield stress of the material is σ_Y . Which of the option(s) given represent(s) the bending stress distribution at cross-section AA after plastic yielding?

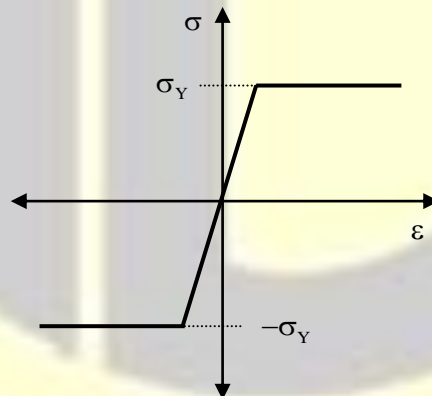

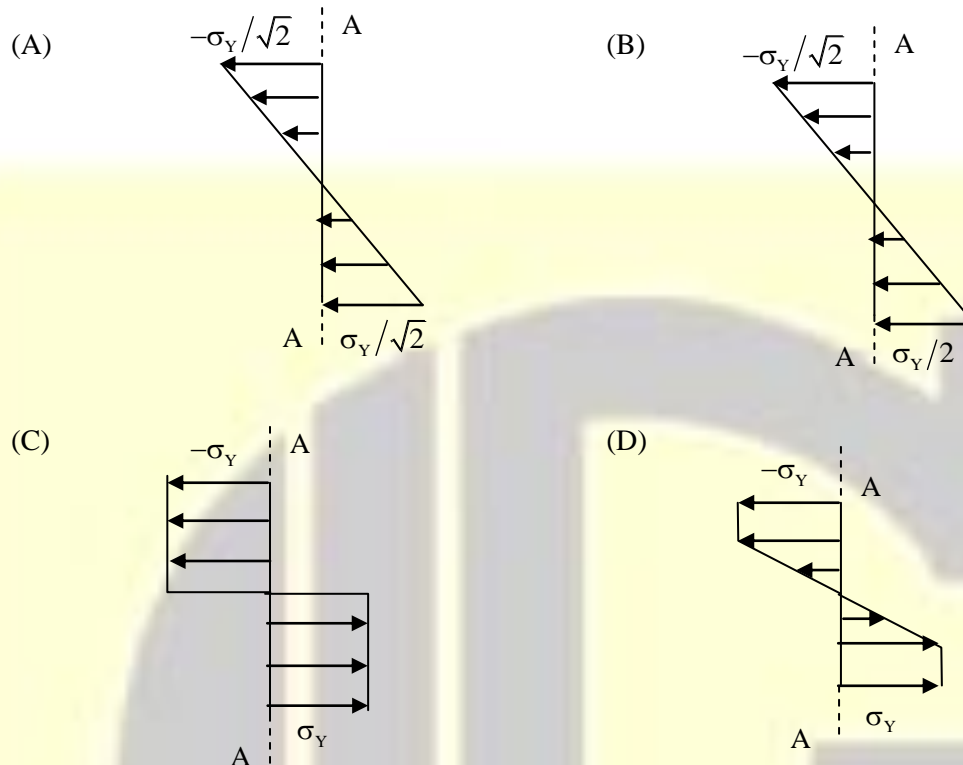

Answer: (C, D)

[Click here to watch video explanation](#)

25. In a metal casting process to manufacture parts, both patterns and moulds provide shape by dictating where the material should or should not go. Which of the option(s) given correctly describe(s) the mould and the pattern?

- (A) Mould walls indicate boundaries within which the molten part material is allowed, while pattern walls indicate boundaries of regions where mould material is not allowed.
- (B) Moulds can be used to make patterns.
- (C) Pattern walls indicate boundaries within which the molten part material is allowed, while mould walls indicate boundaries of regions where mould material is not allowed.
- (D) Patterns can be used to make moulds.

Answer: (A, B, D)

[Click here to watch video explanation](#)

26. The principal stresses at a point P in a solid are 70 MPa, -70 MPa and 0. The yield stress of the material is 100 MPa. Which prediction(s) about material failure at P is/are CORRECT?
- (A) Maximum normal stress theory predicts that the material fails
 - (B) Maximum shear stress theory predicts that the material fails
 - (C) Maximum normal stress theory predicts that the material does not fail
 - (D) Maximum shear stress theory predicts that the material does not fail

Answer: (B, C)

[Click here to watch video explanation](#)

27. Which of the plot(s) shown is/are valid Mohr's circle representations of a plane stress state in a material? (The center of each circle is indicated by O.)

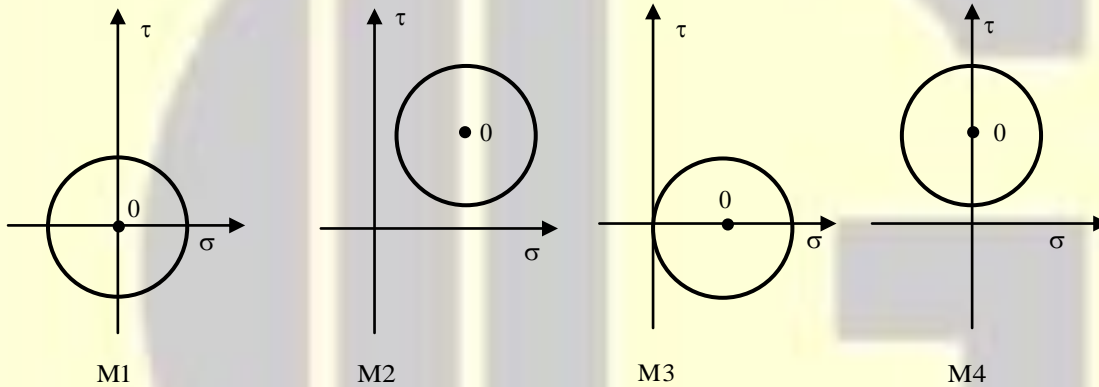

(A) M1

(B) M2

(C) M3

(D) M4

Answer: (A, C)

[Click here to watch video explanation](#)

28. Consider a laterally insulated rod of length L and constant thermal conductivity. Assuming one-dimensional heat conduction in the rod, which of the following steady-state temperature profile(s) can occur without internal heat generation?

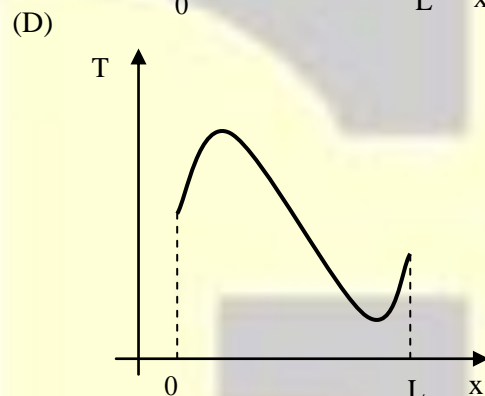
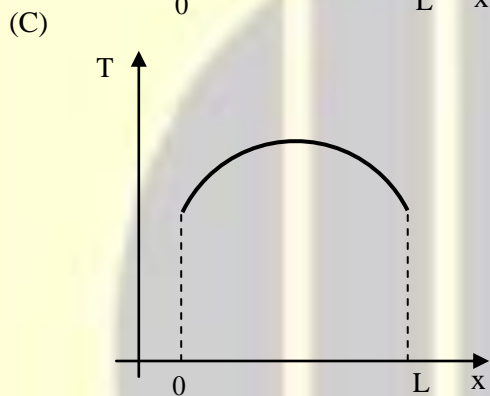
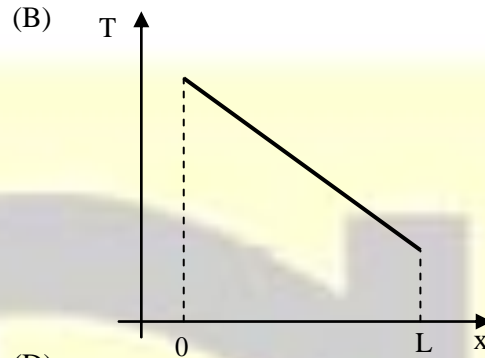
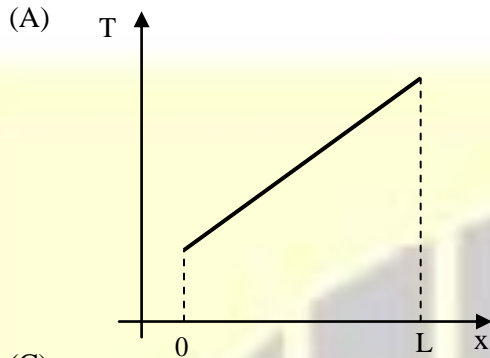

Answer: (A, B)

[Click here to watch video explanation](#)

29. Two meshing spur gears 1 and 2 with diametral pitch of 8 teeth per mm and an angular velocity ratio $|\omega_2|/|\omega_1|=1/4$, have their centers 30 mm apart. The number of teeth on the driver (gear 1) is _____
(Answer in integer)

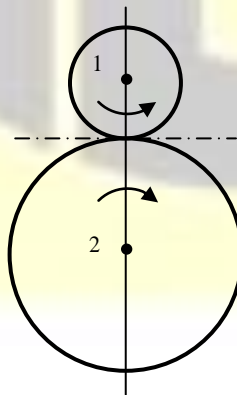

Answer: (96)

[Click here to watch video explanation](#)



GATEFORUM
Engineering Success

GATE REFRESHER COURSE
Mechanical Engineering

GATEFORUM Pioneers in Digital courses for GATE since 2008 offers **GATE refresher course** giving you access to video solutions for previous 11 years GATE questions and Topic-wise formula Compendium (Handbook).

**Enroll now and get 20% discount use
Promo Code **GATEPAPERS****

For more details visit gateforumonline.com

30. The figure shows a block of mass $m = 20$ kg attached to a pair of identical linear springs, each having a spring constant $k = 1000$ N/m. The block oscillates on a frictionless horizontal surface. Assuming free vibrations, the time taken by the block to complete ten oscillations is _____ seconds. (Rounded off to two decimal places)

Take $\pi = 3.14$.

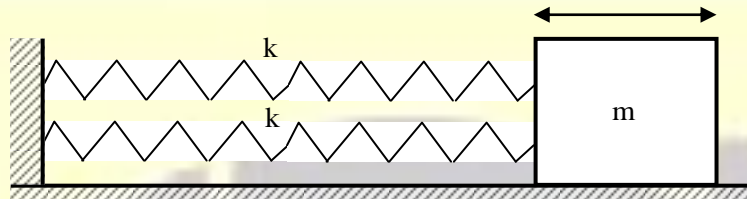

Answer: (6.28)

[Click here to watch video explanation](#)

31. A vector field

$$B(x, y, z) = x\hat{i} + y\hat{j} - 2z\hat{k}$$

is defined over a conical region having height $h = 2$, base radius $r = 3$ and axis along z , as shown in the figure. The base of the cone lies in the x - y plane and is centered at the origin.

If \mathbf{n} denotes the unit outward normal to the curved surface S of the cone, the value of the integral

$$\int_S \mathbf{B} \cdot \mathbf{n} dS$$

Equals _____. (Answer in integer)

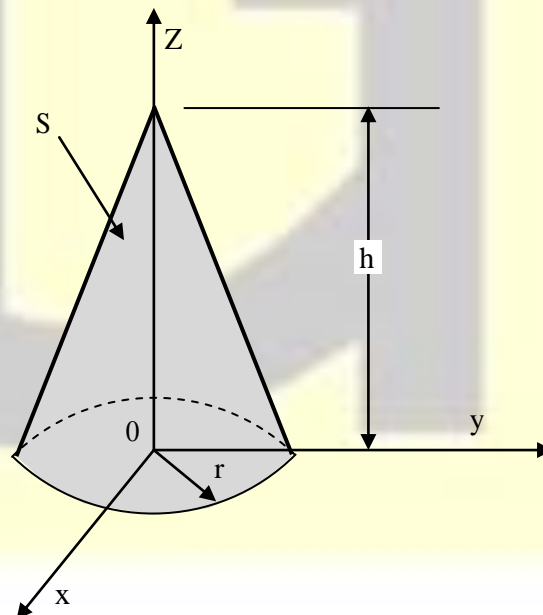

Answer: (0)

[Click here to watch video explanation](#)

32. A linear transformation maps a point (x, y) in the plane to the point (\hat{x}, \hat{y}) according to the rule $\hat{x} = 3y, \hat{y} = 2x$.
Then, the disc $x^2 + y^2 \leq 1$ gets transformed to a region with an area equal to _____ (Rounded off to two decimals)
Use $\pi = 3.14$.

Answer: (18.84)

[Click here to watch video explanation](#)

33. The value of k that makes the complex-valued function analytic, where $f(z) = e^{-kx} (\cos 2y - i \sin 2y)$
Analytic, where $z = x + iy$, is _____
(Answer in integer)

Answer: (2)

[Click here to watch video explanation](#)

34. The braking system shown in the figure uses a belt to slow down a pulley rotating in the clockwise direction by the application of a force P . The belt wraps around the pulley over an angle $\alpha = 270$ degrees. The coefficient of friction between the belt and the pulley is 0.3. The influence of centrifugal forces on the belt is negligible.
During braking, the ratio of the tensions T_1 to T_2 in the belt is equal to _____. (Rounded off to two decimal places)
Take $\pi = 3.14$.

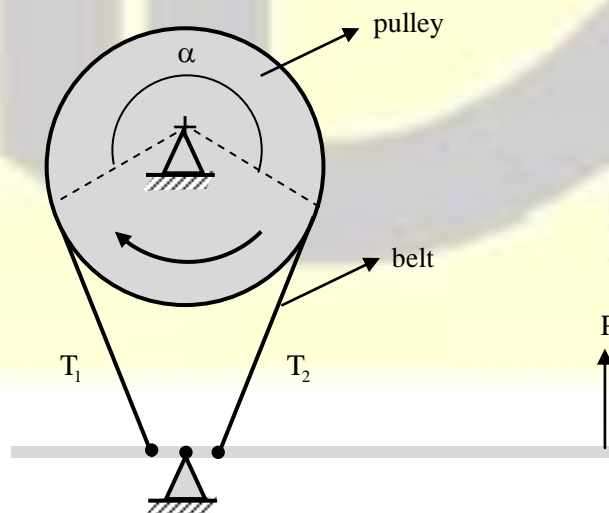

Answer: (4.11)

[Click here to watch video explanation](#)

35. Consider a counter-flow heat exchanger with the inlet temperatures of two fluids (1 and 2) being $T_{1,in} = 300 \text{ K}$ and $T_{2,in} = 350 \text{ K}$. The heat capacity rates of the two fluids are $C_1 = 1000 \text{ W/K}$ and $C_2 = 400 \text{ W/K}$, and the effectiveness of the heat exchanger is 0.5. The actual heat transfer rate is _____ kW.

(Answer in integer)

Answer: (10)

[Click here to watch video explanation](#)

Q. No. 36-65 Carry Two Marks Each

36. Which one of the options given is the inverse Laplace transform of $\frac{1}{s^3 - s}$?

$u(t)$ denotes the unit-step function.

- (A) $\left(-1 + \frac{1}{2}e^{-t} + \frac{1}{2}e^t\right)u(t)$ (B) $\left(\frac{1}{3}e^{-t} - e^t\right)u(t)$
 (C) $\left(-1 + \frac{1}{2}e^{-(t-1)} + \frac{1}{2}e^{(t-1)}\right)u(t-1)$ (D) $\left(-1 - \frac{1}{2}e^{-(t-1)} - \frac{1}{2}e^{(t-1)}\right)u(t-1)$

Answer: (A)

[Click here to watch video explanation](#)

37. A spherical ball weighing 2 kg is dropped from a height of 4.9 m onto an immovable rigid block as shown in the figure. If the collision is perfectly elastic, what is the momentum vector of the ball (in kg m/s) just after impact?

Take the acceleration due to gravity to be $g = 9.8 \text{ m/s}^2$. Options have been rounded off to one decimal place.

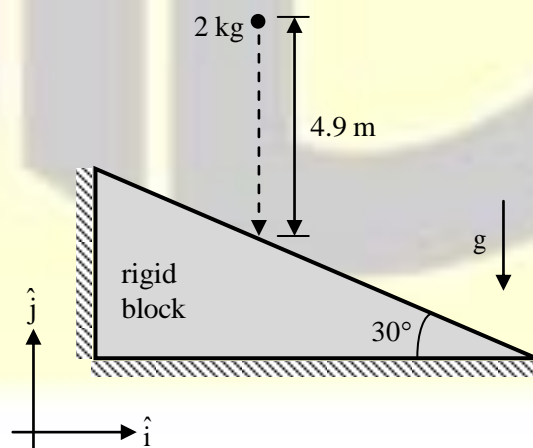

- (A) $19.6\hat{i}$ (B) $19.6\hat{j}$ (C) $17.0\hat{i} + 9.8\hat{j}$ (D) $9.8\hat{i} + 17.0\hat{j}$

Answer: (C)

[Click here to watch video explanation](#)

38. The figure shows a wheel rolling without slipping on a horizontal plane with angular velocity ω_1 . A rigid bar PQ is pinned to the wheel at P while the end Q slides on the floor.

What is the angular velocity ω_2 of the bar PQ?

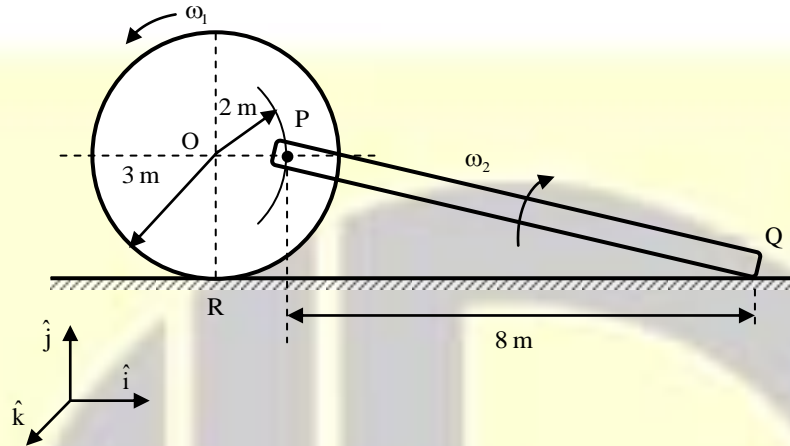

- (A) $\omega_2 = 2\omega_1$ (B) $\omega_2 = \omega_1$ (C) $\omega_2 = 0.5\omega_1$ (D) $\omega_2 = 0.25\omega_1$

Answer: (D)

[Click here to watch video explanation](#)

39. A beam of length L is loaded in the xy -plane by a uniformly distributed load, and by a concentrated tip load parallel to the z -axis, as shown in the figure. The resulting bending moment distributions about the y and the z axes are denoted by M_y and M_z , respectively.

Which one of the options given depicts qualitatively CORRECT variations of M_y and M_z along the length of the beam?

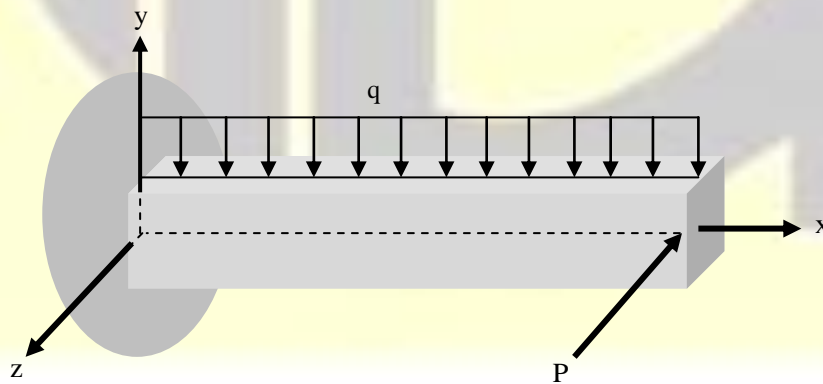

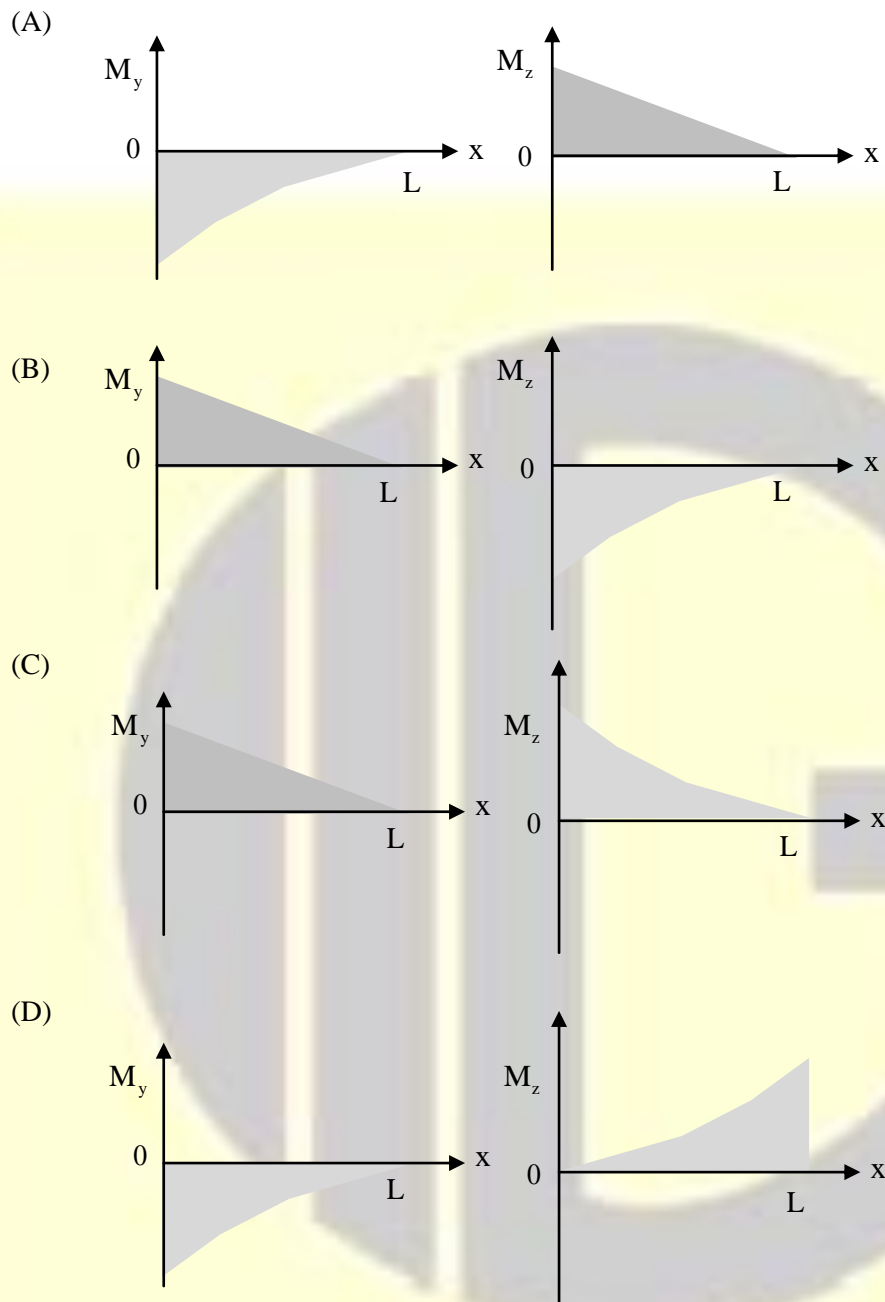

Answer: (B)

[Click here to watch video explanation](#)

40. The figure shows a thin-walled open-top cylindrical vessel of radius r and wall thickness t . The vessel is held along the brim and contains a constant-density liquid to height h from the base. Neglect atmospheric pressure, the weight of the vessel and bending stresses in the vessel walls.

Which one of the plots depicts qualitatively CORRECT dependence of the magnitudes of axial wall stress (σ_1) and circumferential wall stress (σ_2) on y ?

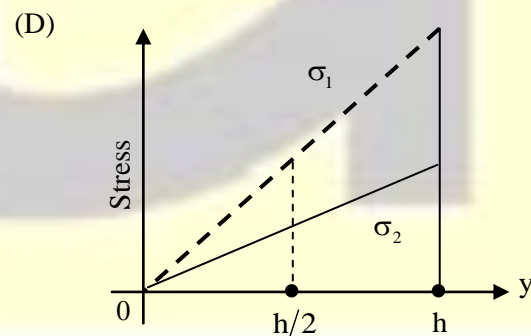
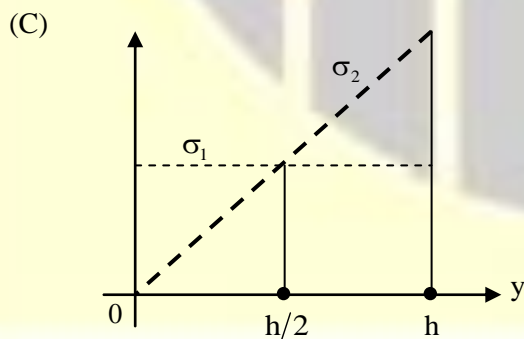
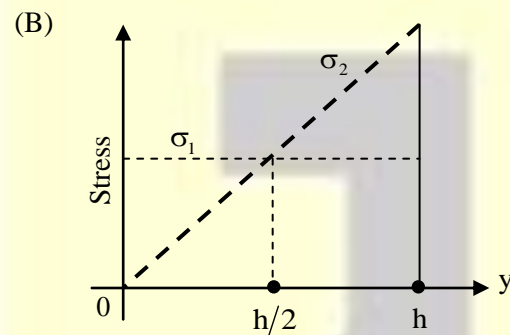
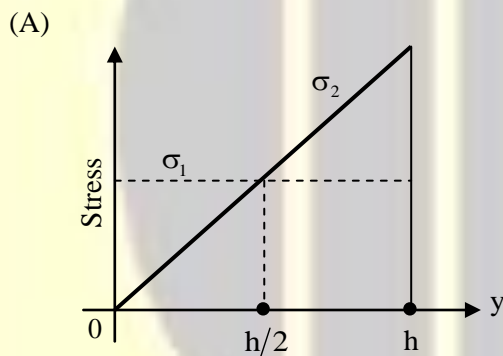
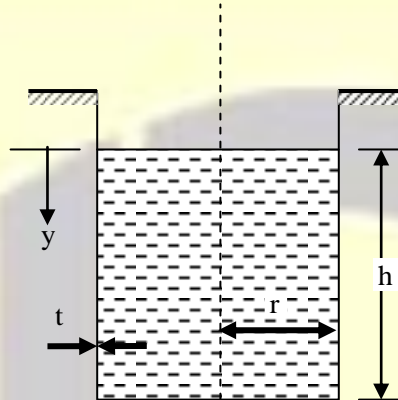

Answer: (A)

[Click here to watch video explanation](#)

41. Which one of the following statements is FALSE?
- (A) For an ideal gas, the enthalpy is independent of pressure.
- (B) For a real gas going through an adiabatic reversible process, the process equation is given by $PV^\gamma = \text{constant}$, where P is the pressure, V is the volume and γ is the ratio of the specific heats of the gas at constant pressure and constant volume.
- (C) For an ideal gas undergoing a reversible polytropic process $PV^{1.5} = \text{constant}$, the equation connecting the pressure, volume and temperature of the gas at any point along the process is $\frac{P}{R} = \frac{mT}{V}$, where R is the gas constant and m is the mass of the gas.
- (D) Any real gas behaves as an ideal gas at sufficiently low pressure or sufficiently high temperature.

Answer: (B)

[Click here to watch video explanation](#)

42. Consider a fully adiabatic piston-cylinder arrangement as shown in the figure. The piston is massless and cross-sectional area of the cylinder is A . The fluid inside the cylinder is air (considered as a perfect gas), with γ being the ratio of the specific heat at constant pressure to the specific heat at constant volume for air. The piston is initially located at a position L_1 . The initial pressure of the air inside the cylinder is $P_1 \gg P_0$, where P_0 , is the atmospheric pressure. The stop S_1 is instantaneously removed and the piston moves to the position S_2 , where the equilibrium pressure of air inside the cylinder is $P_2 \gg P_0$.

What is the work done by the piston on the atmosphere during this process?

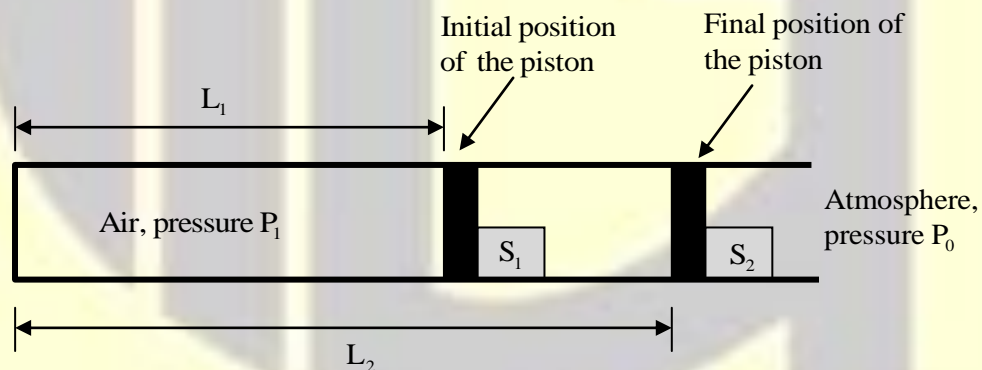

- (A) 0
- (B) $P_0 A (L_2 - L_1)$
- (C) $P_1 A L_1 \ln \frac{L_1}{L_2}$
- (D) $\frac{(P_2 L_2 - P_3 L_1) A}{(1 - \gamma)}$

Answer: (B)

[Click here to watch video explanation](#)

43. A cylindrical rod of length h and diameter d is placed inside a cubic enclosure of side length L . S denotes the inner surface of the cube. The view-factor F_{S-S} is

- (A) 0 (B) 1 (C) $\frac{(\pi dh + \pi d^2/2)}{6L^2}$ (D) $1 - \frac{(\pi dh + \pi d^2/2)}{6L^2}$

Answer: (D)

[Click here to watch video explanation](#)

44. In an ideal orthogonal cutting experiment (see figure), the cutting speed V is 1 m/s, the rake angle of the tool $\alpha = 5^\circ$, and the shear angle, is known to be 45° .

Applying the ideal orthogonal cutting model, consider two shear planes PQ and RS close to each other. As they approach the thin shear zone (shown as a thick line in the figure), plane RS gets sheared with respect to PQ (point R_1 shears to R_2 , and S_1 shears to S_2).

Assuming that the perpendicular distance between PQ and RS is $\delta = 25 \mu\text{m}$, what is the value of shear strain rate (in s^{-1}) that the material undergoes at the shear zone?

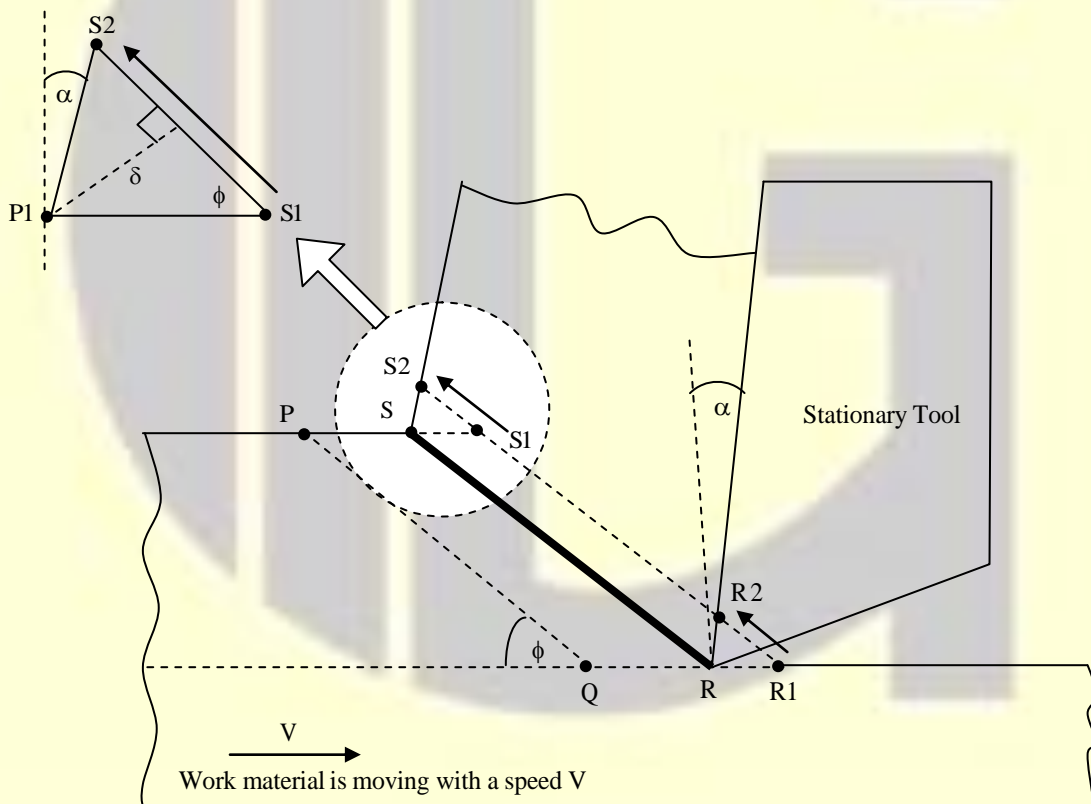

- (A) 1.84×10^4 (B) 5.20×10^4 (C) 0.71×10^4 (D) 1.30×10^4

Answer: (B)

[Click here to watch video explanation](#)

45. A CNC machine has one of its linear positioning axes as shown in the figure, consisting of a motor rotating a lead screw, which in turn moves a nut horizontally on which a table is mounted. The motor moves in discrete rotational steps of 50 steps per revolution. The pitch of the screw is 5 mm and the total horizontal traverse length of the table is 100 mm. What is the total number of controllable locations at which the table can be positioned on this axis?

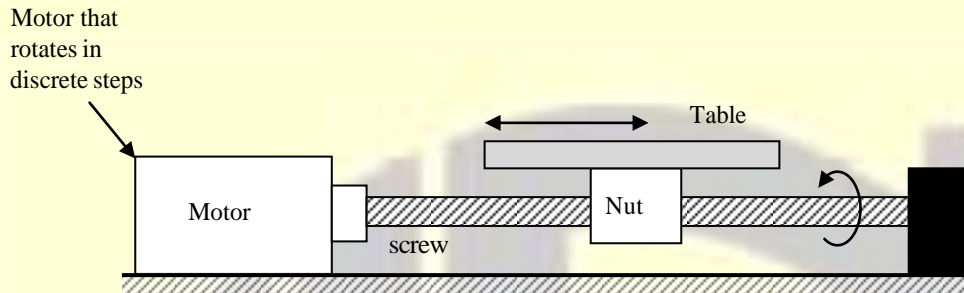

- (A) 5000 (B) 2 (C) 1000 (D) 200

Answer: (C)

[Click here to watch video explanation](#)

46. Cylindrical bars P and Q have identical lengths and radii, but are composed of different linear elastic materials. The Young's modulus and coefficient of thermal expansion of Q are twice the corresponding values of P. Assume the bars to be perfectly bonded at the interface, and their weights to be negligible.

The bars are held between rigid supports as shown in the figure and the temperature is raised by ΔT . Assume that the stress in each bar is homogeneous and uniaxial. Denote the magnitudes of stress in P and Q by σ_1 and σ_2 , respectively.

Which of the statement(s) given is/are CORRECT?

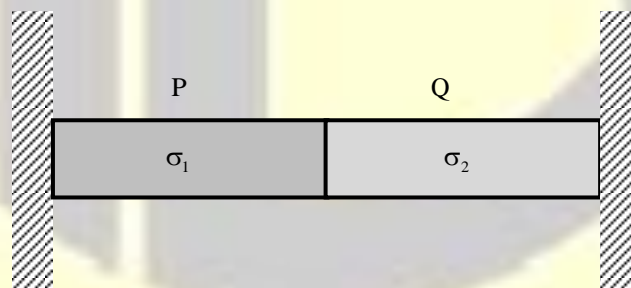

- (A) The interface between P and Q moves to the left after heating
 (B) The interface between P and Q moves to the right after heating
 (C) $\sigma_1 < \sigma_2$
 (D) $\sigma_1 = \sigma_2$

Answer: (A, D)

[Click here to watch video explanation](#)

47. A very large metal plate of thickness d and thermal conductivity k is cooled by a stream of air at temperature $T_\infty = 300$ K with a heat transfer coefficient h , as shown in the figure. The centerline temperature of the plate is T_p . In which of the following case(s) can the lumped parameter model be used to study the heat transfer in the metal plate?

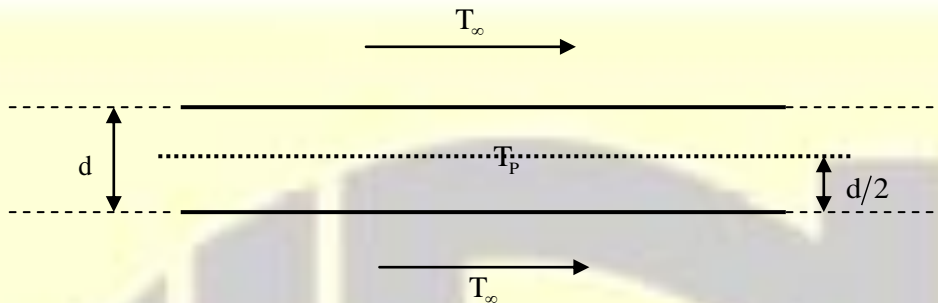

- (A) $h = 10 \text{ Wm}^{-2}\text{K}^{-1}$, $k = 100 \text{ Wm}^{-1}\text{K}^{-1}$, $d = 1 \text{ mm}$, $T_p = 350 \text{ K}$
 (B) $h = 100 \text{ Wm}^{-2}\text{K}^{-1}$, $k = 100 \text{ Wm}^{-1}\text{K}^{-1}$, $d = 1 \text{ m}$, $T_p = 325 \text{ K}$
 (C) $h = 100 \text{ Wm}^{-2}\text{K}^{-1}$, $k = 100 \text{ Wm}^{-1}\text{K}^{-1}$, $d = 1 \text{ mm}$, $T_p = 325 \text{ K}$
 (D) $h = 1000 \text{ Wm}^{-2}\text{K}^{-1}$, $k = 1 \text{ Wm}^{-1}\text{K}^{-1}$, $d = 1 \text{ m}$, $T_p = 350 \text{ K}$

Answer: (A, C)

[Click here to watch video explanation](#)

48. The smallest perimeter that a rectangle with area of 4 square units can have is _____ units.
 (Answer in integer)

Answer: (8)

[Click here to watch video explanation](#)

49. Consider the second-order linear ordinary differential equation

$$x^2 \frac{d^2 y}{dx^2} + x \frac{dy}{dx} - y = 0, x \geq 1$$

with the initial conditions

$$y(x=1) = 6, \left. \frac{dy}{dx} \right|_{x=1} = 2$$

The value of y at $x = 2$ equals _____ .

(Answer in integer)

Answer: (9)

[Click here to watch video explanation](#)

50. The initial value problem is solved numerically using the forward Euler's method with a constant and positive time step of Δt .

Let y_n represent the numerical solution obtained after n steps. The condition $|y_{n+1}| \leq |y_n|$ is satisfied if and only if Δt does not exceed _____.

(Answer in integer)

Answer: (1)

[Click here to watch video explanation](#)

51. The atomic radius of a hypothetical face-centered cubic (FCC) metal is $(\sqrt{2}/10)$ nm. The atomic weight of the metal is 24.092 g/mol. Taking Avogadro's number to be 6.023×10^{23} atoms/mol, the density of the metal is _____ kg/m^3 .

(Answer in integer)

Answer: (2500)

[Click here to watch video explanation](#)

52. A steel sample with 1.5 wt.% carbon (no other alloying elements present) is slowly cooled from 1100°C to just below the eutectoid temperature (723°C). A part of the iron-cementite phase diagram is shown in the figure. The ratio of the pro-eutectoid cementite content to the total cementite content in the microstructure that develops just below the eutectoid temperature is _____.

(Rounded off to two decimal places)

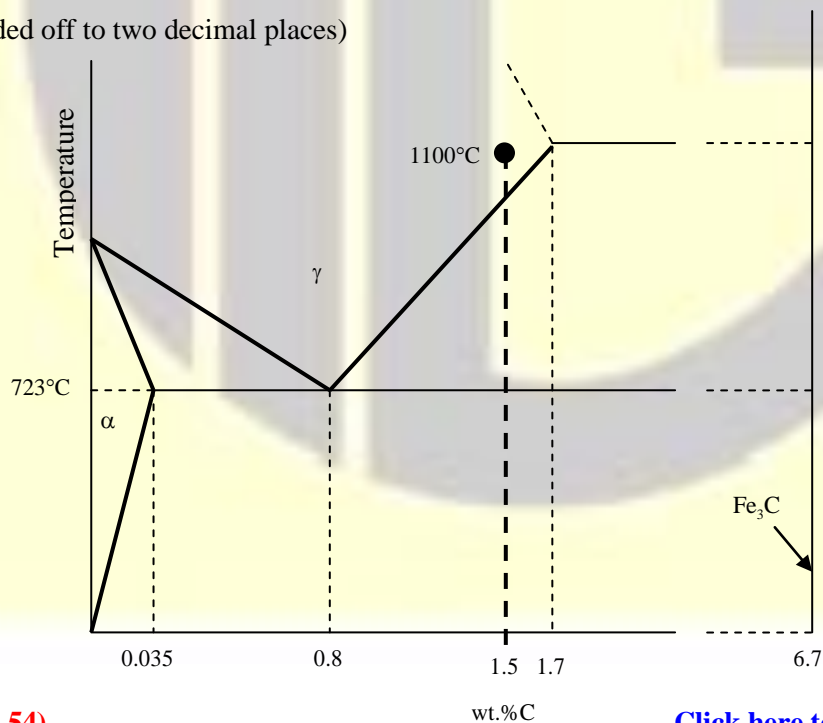

Answer: (0.54)

[Click here to watch video explanation](#)

53. A part, produced in high volumes, is dimensioned as shown. The machining process making this part is known to be statistically in control based on sampling data. The sampling data shows that $D1$ follows a normal distribution with a mean of 20 mm and a standard deviation of 0.3 mm, while $D2$ follows a normal distribution with a mean of 35 mm and a standard deviation of 0.4 mm. An inspection of dimension C is carried out in a sufficiently large number of parts.

To be considered under six-sigma process control, the upper limit of dimension C should be _____ mm.
(Rounded off to one decimal place)

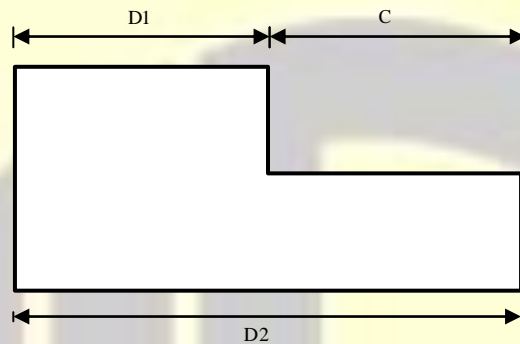

Answer: (16.6)

[Click here to watch video explanation](#)

54. A coordinate measuring machine (CMM) is used to determine the distance between Surface SP and Surface SQ of an approximately cuboidal shaped part. Surface SP is declared as the datum as per the engineering drawing used for manufacturing this part. The CMM is used to measure four points $P1, P2, P3, P4$ on Surface SP, and four points $Q1, Q2, Q3, Q4$ on Surface SQ as shown. A regression procedure is used to fit the necessary planes.

The distance between the two fitted planes is _____ mm. (Answer in integer)

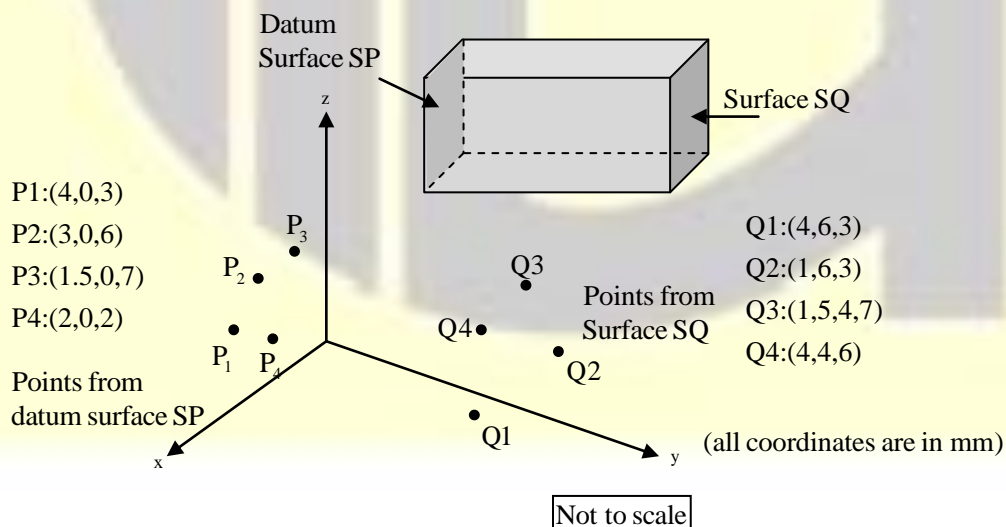

Answer: (5)

[Click here to watch video explanation](#)

55. A solid part (see figure) of polymer material is to be fabricated by additive manufacturing (AM) in square-shaped layers starting from the bottom of the part working upwards. The nozzle diameter of the AM machine is $a/10$ mm and the nozzle follows a linear serpentine path parallel to the sides of the square layers with a feed rate of $a/5$ mm/min.

Ignore any tool path motions other than those involved in adding material, and any other delays between layers or the serpentine scan lines.

The time taken to fabricate this part is _____ minutes. (Answer in integer)

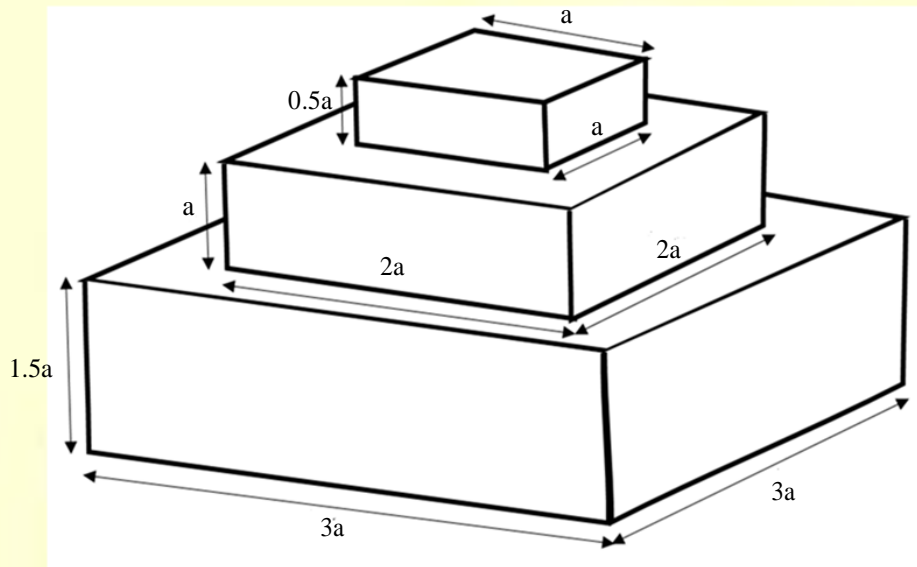

Not to scale

All dimensions are in mm

Answer: (11458)

[Click here to watch video explanation](#)

56. An optical flat is used to measure the height difference between a reference slip gauge A and a slip gauge B. Upon viewing via the optical flat using a monochromatic light of wavelength $0.5 \mu\text{m}$, 12 fringes were observed over a length of 15 mm of gauge B. If the gauges are placed 45 mm apart, the height difference of the gauges is _____ m. (Answer in integer)

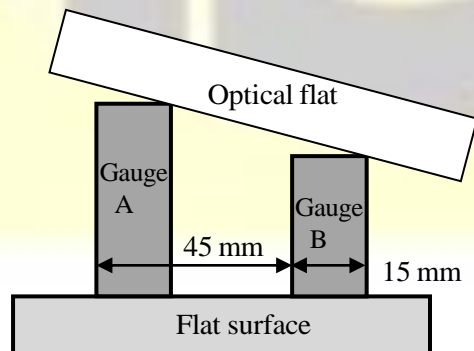

Answer: (9)

[Click here to watch video explanation](#)

57. Ignoring the small elastic region, the true stress (σ)-true strain (ϵ) variation of a material beyond yielding follows the equation $\sigma = 400 \epsilon^{0.3}$ MPa. The engineering ultimate tensile strength value of this material is _____ MPa.

(Rounded off to one decimal place)

Answer: (206.47)

[Click here to watch video explanation](#)

58. The area moment of inertia about the y-axis of a linearly tapered section shown in the figure is _____ m^4 . (Answer in integer)

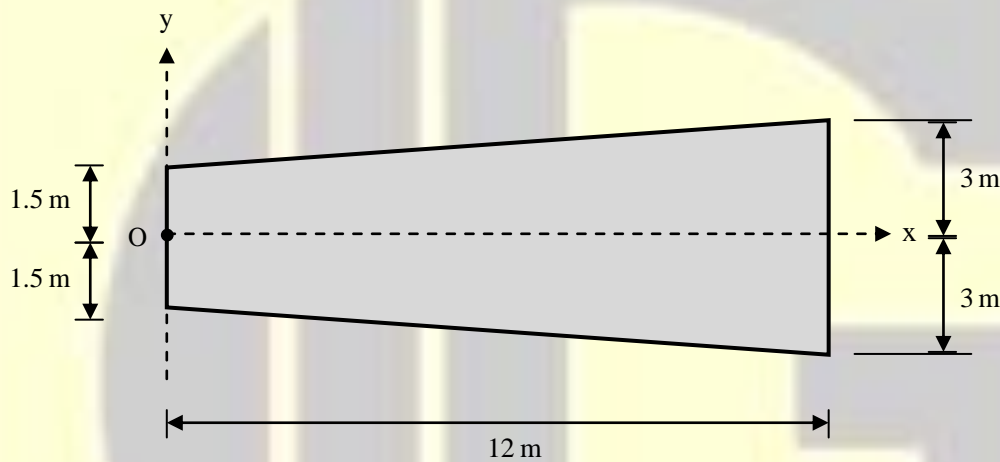

Answer: (3024)

[Click here to watch video explanation](#)

59. A cylindrical bar has a length $L = 5$ m and cross section area $S = 10$ m². The bar is made of a linear elastic material with a density $\rho = 2700$ kg/m³ and Young's modulus $E = 70$ GPa. The bar is suspended as shown in the figure and is in a state of uniaxial tension due to its self-weight.

The elastic strain energy stored in the bar equals _____ J. (Rounded off to two decimal places)

Take the acceleration due to gravity as $g = 9.8$ m/s².

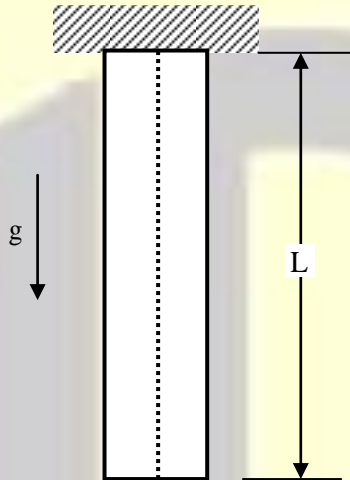

Answer: (2.08)

[Click here to watch video explanation](#)

60. A cylindrical transmission shaft of length 1.5 m and diameter 100 mm is made of a linear elastic material with a shear modulus of 80 GPa. While operating at 500 rpm, the angle of twist across its length is found to be 0.5 degrees.

The power transmitted by the shaft at this speed is _____ kW. (Rounded off to two decimal places)

Take $\pi = 3.14$.

Answer: (239.34)

[Click here to watch video explanation](#)

61. Consider a mixture of two ideal gases, X and Y, with molar masses

$\bar{M}_X = 10$ kg/kmol and $\bar{M}_Y = 20$ kg/kmol, respectively, in a container. The total pressure in the container is 100 kPa, the total volume of the container is 10 m³ and the temperature of the contents of the container is 300 K. If the mass of gas-X in the container is 2 kg, then the mass of gas-Y in the container is kg. (Rounded off to one decimal place)

Assume that the universal gas constant is 8314 J kmol⁻¹K⁻¹.

Answer: (4.019)

[Click here to watch video explanation](#)

62. The velocity field of a certain two-dimensional flow is given by

$$V(x, y) = k(\hat{x}i - y\hat{j})$$

Where $k = 2s^{-1}$. The coordinates x and y are in meters. Assume gravitational effects to be negligible.

If the density of the fluid is 1000 kg/m^3 and the pressure at the origin is 100 kPa , the pressure at the location $(2 \text{ m}, 2 \text{ m})$ is kPa .

(Answer in integer)

Answer: (84)

[Click here to watch video explanation](#)

63. Consider a unidirectional fluid flow with the velocity field given by

$$V(x, y, z, t) = u(x, t)\hat{i}$$

Where $u(0, t) = 1$. If the spatially homogeneous density field varies with time

$$\rho(t) = 1 + 0.2e^{-t}$$

the value of $u(2, 1)$ is _____. (Rounded off to two decimal places)

Assume all quantities to be dimensionless.

Answer: (1.14)

[Click here to watch video explanation](#)

64. The figure shows two fluids held by a hinged gate. The atmospheric pressure is $P_a = 100 \text{ kPa}$.

The moment per unit width about the base of the hinge is _____ kNm/m . (Rounded off to one decimal place)

Take the acceleration due to gravity to be $g = 9.8 \text{ m/s}^2$.

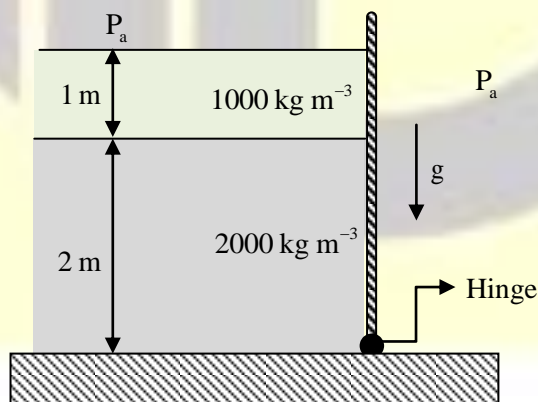

Not to scale

Answer: (57.3)

[Click here to watch video explanation](#)

65. An explosion at time $t = 0$ releases energy E at the origin in a space filled with a gas of density. Subsequently, a hemispherical blast wave propagates radially outwards as shown in the figure. Let R denote the radius of the front of the hemispherical blast wave. The radius R follows the relationship $R = kt^a E^b \rho^c$, where k is a dimensionless constant. The value of exponent a is _____ .
(Rounded off to one decimal place)

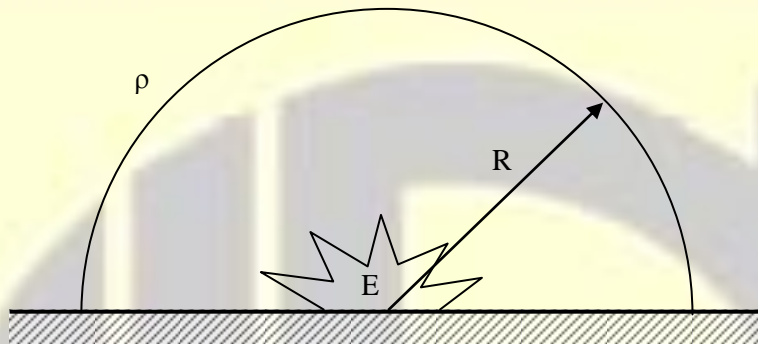

Answer: (0.4)

[Click here to watch video explanation](#)





Follow us @



For more details visit gateforumonline.com