



*GATE PREVIOUS YEAR SOLVED PAPERS*  
**Electrical Engineering  
Previous Year Solved Papers**

**GATEFORUM** Pioneers in Digital courses for GATE since 2008 has long history of training students through innovative courses. Currently GATEFORUM offers a wide range of courses from eGATE, GATE Online, Gdrive to Online TarGATE. Since inception, we have trained more 3,00,000 students since inception.

**For more details visit [gateforumonline.com](http://gateforumonline.com)**

## GENERAL APTITUDE

### Q. No. 1 - 5 Carry One Mark Each

1. Rafi told Mary, "I am thinking of watching a film this weekend." The following reports the above statement in indirect speech: Rafi told Mary that he \_\_\_\_\_ of watching a film that weekend.
- (A) thought (B) is thinking  
(C) am thinking (D) was thinking

**Answer: (D)**

[Click here to watch video explanation](#)

2. Permit : \_\_\_\_\_ : Enforce : Relax  
(By word meaning)
- (A) Allow (B) Forbid (C) License (D) Reinforce

**Answer: (B)**

[Click here to watch video explanation](#)

3. Given a fair six-faced dice where the faces are labelled '1', '2', '3', '4', '5', and '6', what is the probability of getting a '1' on the first roll of the dice and a '4' on the second roll?
- (A)  $\frac{1}{36}$  (B)  $\frac{1}{6}$  (C)  $\frac{5}{6}$  (D)  $\frac{1}{3}$

**Answer: (A)**

[Click here to watch video explanation](#)

4. A recent survey shows that 65% of tobacco users were advised to stop consuming tobacco. The survey also shows that 3 out of 10 tobacco users attempted to stop using tobacco.
- Based only on the information in the above passage, which one of the following options can be logically inferred with certainty?
- (A) A majority of tobacco users who were advised to stop consuming tobacco made an attempt to do so.  
(B) A majority of tobacco users who were advised to stop consuming tobacco did not attempt to do so.  
(C) Approximately 30% of tobacco users successfully stopped consuming tobacco.  
(D) Approximately 65% of tobacco users successfully stopped consuming tobacco.

**Answer: (B)**

[Click here to watch video explanation](#)

5. How many triangles are present in the given figure?

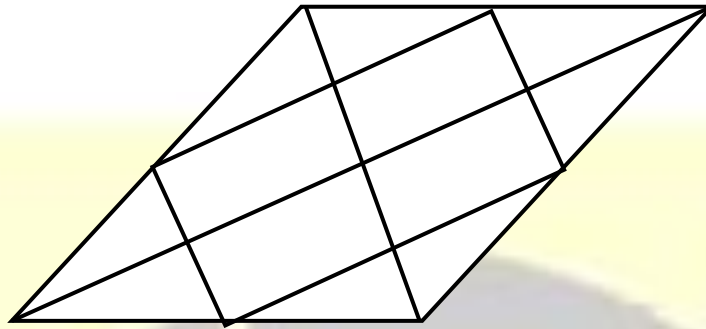

- (A) 12                      (B) 16                      (C) 20                      (D) 24

**Answer: (C)**

[Click here to watch video explanation](#)

**Q. No. 6–10 Carry Two Marks Each**

6. Students of all the departments of a college who have successfully completed the registration process are eligible to vote in the upcoming college elections. However, by the time the due date for registration was over, it was found that surprisingly none of the students from the Department of Human Sciences had completed the registration process.

Based only on the information provided above, which one of the following sets of statement(s) can be logically inferred with certainty?

- (i) All those students who would not be eligible to vote in the college elections would certainly belong to the Department of Human Sciences.
- (ii) None of the students from departments other than Human Sciences failed to complete the registration process within the due time.
- (iii) All the eligible voters would certainly be students who are not from the Department of Human Sciences.

- (A) (i) and (ii)                      (B) (i) and (iii)                      (C) only (i)                      (D) only (iii)

**Answer: (D)**

[Click here to watch video explanation](#)

7. Which one of the following options represents the given graph?

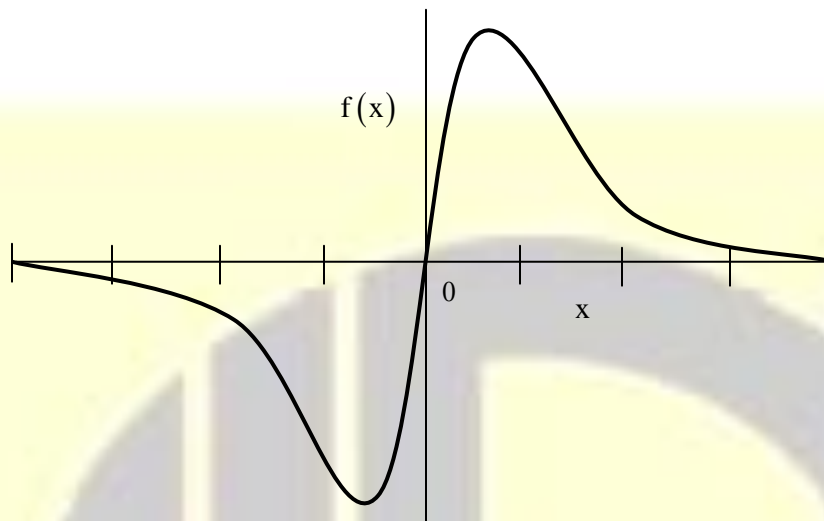

(A)  $f(x) = x^2 2^{-|x|}$

(B)  $f(x) = x 2^{-|x|}$

(C)  $f(x) = |x| 2^{-x}$

(D)  $f(x) = x 2^{-x}$

**Answer: (B)**

[Click here to watch video explanation](#)

8. Which one of the options does NOT describe the passage below or follow from it?

We tend to think of cancer as a ‘modern’ illness because its metaphors are so modern. It is a disease of overproduction, of sudden growth, a growth that is unstoppable, tipped into the abyss of no control. Modern cell biology encourages us to imagine the cell as a molecular machine. Cancer is that machine unable to quench its initial command (to grow) and thus transform into an indestructible, self-propelled automaton.

[Adapted from The Emperor of All Maladies by Siddhartha Mukherjee]

- (A) It is a reflection of why cancer seems so modern to most of us.
- (B) It tells us that modern cell biology uses and promotes metaphors of machinery.
- (C) Modern cell biology encourages metaphors of machinery, and cancer is often imagined as a machine.
- (D) Modern cell biology never uses figurative language, such as metaphors, to describe or explain anything.

**Answer: (D)**

[Click here to watch video explanation](#)

9. The digit in the unit's place of the product  $3^{999} \times 7^{1000}$  is \_\_\_\_\_

- (A) 7                      (B) 1                      (C) 3                      (D) 9

**Answer: (A)**

[Click here to watch video explanation](#)

10. A square with sides of length 6 cm is given. The boundary of the shaded region is defined by two semi-circles whose diameters are the sides of the square, as shown. The area of the shaded region is \_\_\_\_\_  $\text{cm}^2$ .

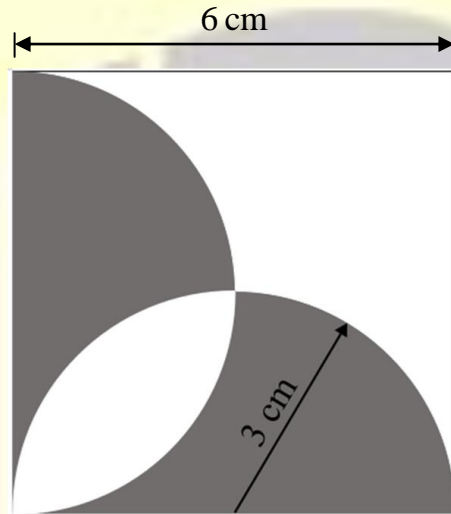

- (A)  $6\pi$                       (B) 18                      (C) 20                      (D)  $9\pi$

**Answer: (B)**

[Click here to watch video explanation](#)

**ELECTRICAL ENGINEERING**

**Q. No. 11 to 35 Carry One Mark Each**

11. For a given vector  $w = [1 \ 2 \ 3]^T$ , the vector normal to the plane defined by  $w^T x = 1$  is

(A)  $[-2 \ -2 \ 2]^T$

(B)  $[3 \ 0 \ -1]^T$

(C)  $[3 \ 2 \ 1]^T$

(D)  $[1 \ 2 \ 3]^T$

**Answer: (D)**

[Click here to watch video explanation](#)

12. For the block diagram shown in the figure, the transfer function  $\frac{Y(s)}{R(s)}$  is

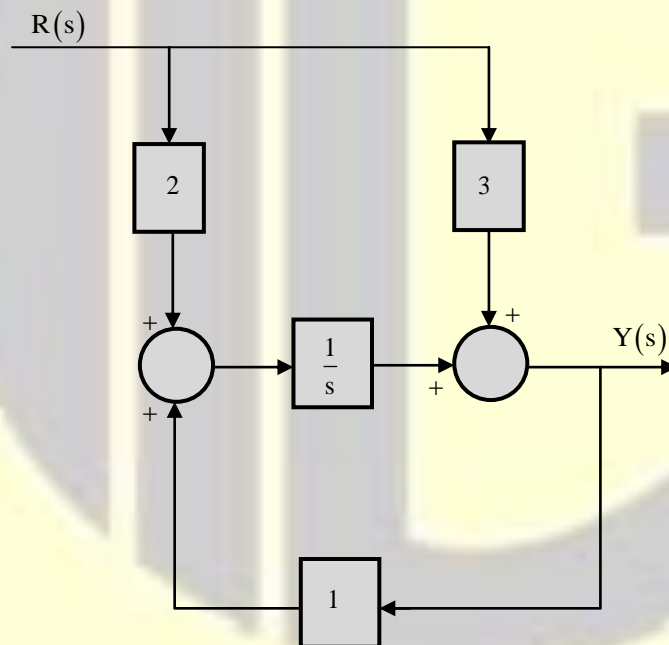

(A)  $\frac{2s+3}{s+1}$

(B)  $\frac{3s+2}{s-1}$

(C)  $\frac{s+1}{3s+2}$

(D)  $\frac{3s+2}{s+1}$

**Answer: (B)**

[Click here to watch video explanation](#)

13. In the Nyquist plot of the open-loop transfer function

$$G(s)H(s) = \frac{3s+5}{s-1}$$

corresponding to the feedback loop shown in the figure, the infinite semi-circular arc of the Nyquist contour in s-plane is mapped into a point at

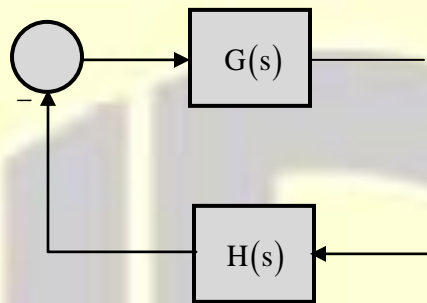

- (A)  $G(s)H(s) = \infty$                       (B)  $G(s)H(s) = 0$   
 (C)  $G(s)H(s) = 3$                       (D)  $G(s)H(s) = -5$

**Answer:** (C)

[Click here to watch video explanation](#)

14. Consider a unity-gain negative feedback system consisting of the plant  $G(s)$  (given below) and a proportional-integral controller. Let the proportional gain and integral gain be 3 and 1, respectively. For a unit step reference input, the final values of the controller output and the plant output, respectively, are

$$G(s) = \frac{1}{s-1}$$

- (A)  $\infty, \infty$                       (B) 1, 0                      (C) 1, -1                      (D) -1, 1

**Answer:** (D)

[Click here to watch video explanation](#)

15. The following columns present various modes of induction machine operation and the ranges of slip

A	B
<u>Mode of Operation</u>	<u>Range of Slip</u>
a. Running in generator mode	p. From 0.0 to 1.0
b. Running in motor mode	q. From 1.0 to 2.0
c. Plugging in motor mode	r. From -1.0 to 0.0

The correct matching between the elements in column **A** with those of column **B** is

- (A) a-r, b-p, and c-q  
 (B) a-r, b-q, and c-p  
 (C) a-p, b-r, and c-q  
 (D) a-q, b-p, and c-r

**Answer: (A)**

[Click here to watch video explanation](#)

16. A 10-pole, 50 Hz, 240 V, single phase induction motor runs at 540 RPM while driving rated load. The frequency of induced rotor currents due to backward field is

- (A) 100 Hz                      (B) 95 Hz                      (C) 10 Hz                      (D) 5 Hz

**Answer: (B)**

[Click here to watch video explanation](#)

17. A continuous-time system that is initially at rest is described by

$$\frac{dy(t)}{dt} + 3y(t) = 2x(t),$$

Where  $x(t)$  is the input voltage and  $y(t)$  is the output voltage. The impulse response of the system is

- (A)  $3e^{-2t}$                       (B)  $\frac{1}{3}e^{-2t}u(t)$                       (C)  $2e^{-3t}u(t)$                       (D)  $2e^{-3t}$

**Answer: (C)**

[Click here to watch video explanation](#)

18. The Fourier transform  $X(\omega)$  of the signal  $x(t)$  is given by

$$X(\omega) = 1, \text{ for } |\omega| < W_0 \\ = 0, \text{ for } |\omega| > W_0$$

Which one of the following statements is true?



- (A)  $x(t)$  tends to be an impulse as  $W_0 \rightarrow \infty$ .      (B)  $x(0)$  decreases as  $W_0$  increases  
 (C) At  $t = \frac{\pi}{2W_0}$ ,  $x(t) = -\frac{1}{\pi}$       (D) At  $t = \frac{\pi}{2W_0}$ ,  $x(t) = \frac{1}{\pi}$

**Answer: (A)**

[Click here to watch video explanation](#)

19. The Z-transform of a discrete signal  $x[n]$  is

$$X(z) = \frac{4z}{\left(z - \frac{1}{5}\right)\left(z - \frac{2}{3}\right)(z-3)} \text{ with ROC} = R$$

Which one of the following statements is true?

- (A) Discrete-time Fourier transform of  $x[n]$  converges if  $R$  is  $|z| > 3$   
 (B) Discrete-time Fourier transform of  $x[n]$  converges if  $R$  is  $\frac{2}{3} < |z| < 3$   
 (C) Discrete-time Fourier transform of  $x[n]$  converges if  $R$  is such that  $x[n]$  is a left sided sequence  
 (D) Discrete-time Fourier transform of  $x[n]$  converges if  $R$  is such that  $x[n]$  is a right sided sequence

**Answer: (B)**

[Click here to watch video explanation](#)

20. For the three-bus power system shown in the figure, the trip signals to the circuit breakers B1 to B9 are provided by over current relays R1 to R9, respectively, some of which have directional properties also. The necessary condition for the system to be protected for short circuit fault at any part of the system between bus 1 and the R-L loads with isolation of minimum portion of the network using minimum number of directional relays is

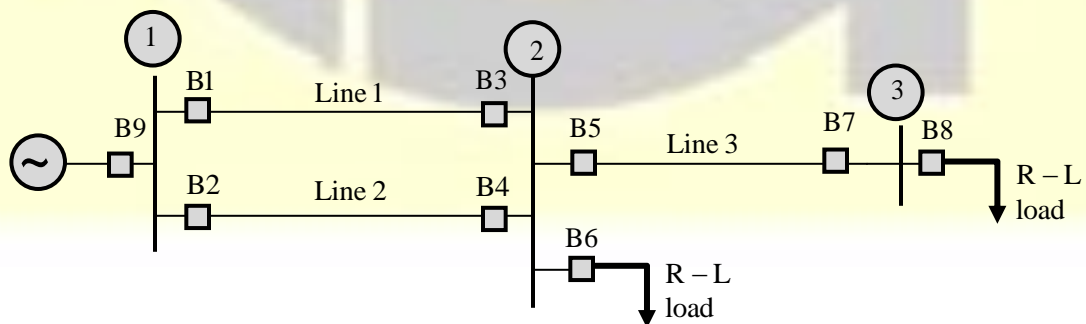

- (A)  $R_3$  and  $R_4$  are directional over current relays blocking faults towards bus 2
- (B)  $R_3$  and  $R_4$  are directional overcurrent relays blocking faults towards bus 2 and  $R_7$  is directional overcurrent relay blocking faults towards bus 3
- (C)  $R_3$  and  $R_4$  are directional overcurrent relays blocking faults towards Line 1 and Line 2, respectively,  $R_7$  is directional overcurrent relay blocking faults towards Line 3 and  $R_5$  is directional overcurrent relay blocking faults towards bus 2
- (D)  $R_3$  and  $R_4$  are directional overcurrent relays blocking faults towards Line 1 and Line 2, respectively.

**Answer:** (C)

[Click here to watch video explanation](#)

21. The expressions of fuel cost of two thermal generating units as a function of the respective power generation  $P_{G1}$  and  $P_{G2}$  are given as

$$F_1(P_{G1}) = 0.1aP_{G1}^2 + 40P_{G1} + 120 \text{ Rs/hour} \quad 0 \text{ MW} \leq P_{G1} \leq 350 \text{ MW}$$

$$F_2(P_{G2}) = 0.2P_{G2}^2 + 30P_{G2} + 100 \text{ Rs/hour} \quad 0 \text{ MW} \leq P_{G2} \leq 300 \text{ MW}$$

Where  $a$  is a constant. For a given value of  $a$ , optimal dispatch requires the total load of 290 MW to be shared as  $P_{G1} = 175 \text{ MW}$  and  $P_{G2} = 115 \text{ MW}$ . With the load remaining unchanged, the value of  $a$  is increased by 10% and optimal dispatch is carried out. The changes in  $P_{G1}$  and the total cost of generation,  $F (= F_1 + F_2)$  in Rs/hour will be as follows

- (A)  $P_{G1}$  will decrease and  $F$  will increase
- (B) Both  $P_{G1}$  and  $F$  will increase
- (C)  $P_{G1}$  will increase and  $F$  will decrease
- (D) Both  $P_{G1}$  and  $F$  will decrease

**Answer:** (A)

[Click here to watch video explanation](#)

22. The four stator conductors (A, A', B and B') of a rotating machine are carry DC currents of the same value, the directions of which are shown in the figure (i). The rotor coils a-a' and b-b' are formed by connecting the back ends of conductors 'a' and 'a'' and 'b' and 'b'', respectively, as shown in figure (ii). The e.m.f induced in coil a-a' and coil b-b' are denoted by  $E_{a-a'}$  and  $E_{b-b'}$ , respectively. If the rotor is rotated at uniform angular speed  $\omega$  rad/s in the clockwise direction then which of the following correctly describe the  $E_{a-a'}$  and  $E_{b-b'}$ ?

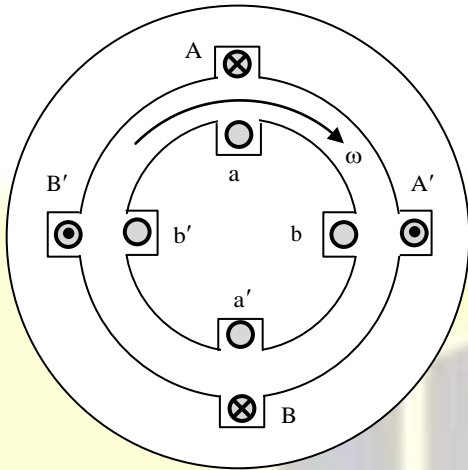

Figure (i) : Cross-sectional view

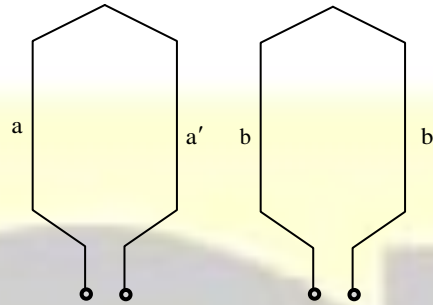

Figure (ii) : rotor winding connection diagram

- (A)  $E_{a-a'}$  and  $E_{b-b'}$  have finite magnitudes and are in the same phase
- (B)  $E_{a-a'}$  and  $E_{b-b'}$  have finite magnitude with  $E_{b-b'}$  leading  $E_{a-a'}$
- (C)  $E_{a-a'}$  and  $E_{b-b'}$  have finite magnitudes with  $E_{a-a'}$  leading  $E_{b-b'}$
- (D)  $E_{a-a'} = E_{b-b'} = 0$

**Answer: (D)**

[Click here to watch video explanation](#)

23. The chopper circuit shown in figure (i) feeds power to a 5 A DC constant current source. The switching frequency of the chopper is 100 kHz. All the components can be assumed to be ideal. The gate signals of switches  $S_1$  and  $S_2$  are shown in figure (ii). Average voltage across the 5 A current source is

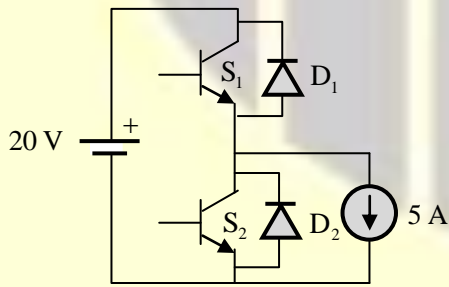

Figure (i)

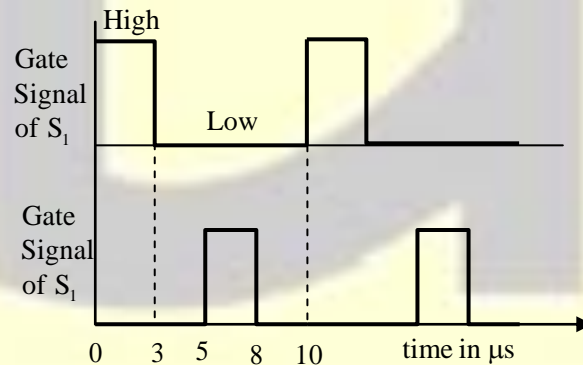

Figure (ii)

- (A) 10 V
- (B) 6 V
- (C) 12 V
- (D) 20 V

**Answer: (B)**

[Click here to watch video explanation](#)

24. In the figure, the vectors  $u$  and  $v$  are related as:  $Au = v$  by a transformation matrix  $A$ . The correct choice of  $A$  is

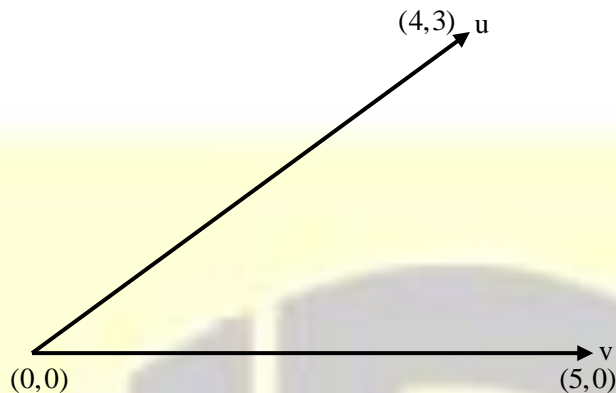

(A)  $\begin{bmatrix} \frac{4}{5} & \frac{3}{5} \\ -\frac{3}{5} & \frac{4}{5} \end{bmatrix}$

(B)  $\begin{bmatrix} \frac{4}{5} & \frac{3}{5} \\ \frac{3}{5} & \frac{4}{5} \end{bmatrix}$

(C)  $\begin{bmatrix} \frac{4}{5} & \frac{3}{5} \\ \frac{3}{5} & \frac{4}{5} \end{bmatrix}$

(D)  $\begin{bmatrix} \frac{4}{5} & \frac{3}{5} \\ \frac{3}{5} & -\frac{4}{5} \end{bmatrix}$

**Answer:** (A)

[Click here to watch video explanation](#)

25. One million random numbers are generated from a statistically stationary process with Gaussian distribution with mean zero and standard deviation  $\sigma_0$ .

The  $\sigma_0$  is estimated by randomly drawing out 10,000 numbers of samples  $(x_n)$ . The estimates  $\hat{\sigma}_1, \hat{\sigma}_2$  are computed in the following two ways.

$$\hat{\sigma}_1^2 = \frac{1}{10000} \sum_{n=1}^{10000} x_n^2 \quad \hat{\sigma}_2^2 = \frac{1}{9999} \sum_{n=1}^{10000} x_n^2$$

Which of the following statements is true?

(A)  $E(\hat{\sigma}_2^2) = \sigma_0^2$

(B)  $E(\hat{\sigma}_2) = \sigma_0$

(C)  $E(\hat{\sigma}_1^2) = \sigma_0^2$

(D)  $E(\hat{\sigma}_1) = E(\hat{\sigma}_2)$

**Answer:** (A)

[Click here to watch video explanation](#)

26. A semiconductor switch needs to block voltage  $V$  of only one polarity ( $V > 0$ ) during OFF state as shown in figure (i) and carry current in both directions during ON state as shown in figure (ii). Which of the following switch combination(s) will realize the same?

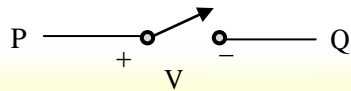

Figure (i)

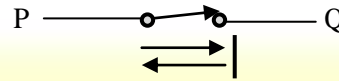
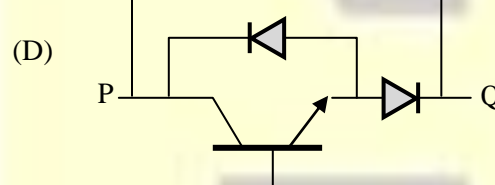
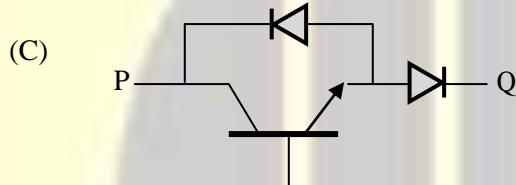
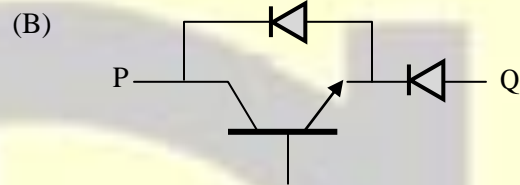
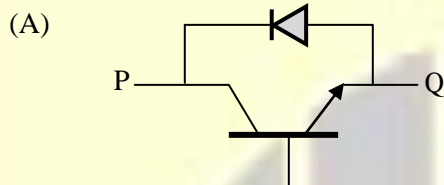

Figure (ii)



**Answer:** (A, D)

[Click here to watch video explanation](#)

27. Which of the following statement(s) is/are true?
- (A) If an LTI system is causal, it is stable
  - (B) A discrete time LTI system is causal, if and only if its response to a step input  $[n]$  is 0 for  $n < 0$
  - (C) If a discrete time LTI system has an impulse response  $h[n]$  of finite duration, the system is stable
  - (D) If the impulse response  $0 < |h[n]| < 1$  for all  $n$ , then the LTI system is stable.

**Answer:** (B)

[Click here to watch video explanation](#)

28. The bus admittance ( $Y_{bus}$ ) matrix of a 3-bus power system is given below.

$$\begin{matrix}
 & \begin{matrix} 1 & 2 & 3 \end{matrix} \\
 \begin{matrix} 1 \\ 2 \\ 3 \end{matrix} & \begin{bmatrix} -j15 & j10 & j5 \\ j10 & -j13.5 & j4 \\ j5 & j4 & -j8 \end{bmatrix}
 \end{matrix}$$

Considering that there is no shunt inductor connected to any of the buses, which of the following can NOT be true?

- (A) Line charging capacitor of finite value is present in all three lines
- (B) Line charging capacitor of finite value is present in line 2-3 only
- (C) Line charging capacitor of finite value is present in line 2-3 only and shunt capacitor of finite value is present in bus 1 only
- (D) Line charging capacitor of finite value is present in line 2-3 only and shunt capacitor of finite value is present in bus 3 only

**Answer:** (A, C)

[Click here to watch video explanation](#)

29. The value of parameters of the circuit shown in the figure are

$$R_1 = 2\Omega, R_2 = 2\Omega, R_3 = 3\Omega, L = 10 \text{ mH}, C = 100 \mu\text{F}$$

For time  $t < 0$ , the circuit is at steady state with the switch 'K' in closed condition. If the switch is opened at  $t = 0$ , the value of the voltage across the inductor ( $V_L$ ) at  $t = 0^+$  in Volts is \_\_\_\_\_ (Round off to 1 decimal place).

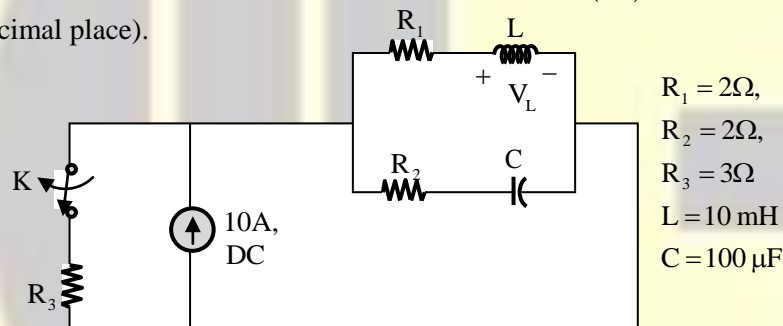

**Answer:** (8)

[Click here to watch video explanation](#)

30. A separately excited DC motor rated 400 V, 15 A, 1500 RPM drives a constant torque load at rated speed operating from 400 V DC supply drawing rated current. The armature resistance is  $1.2 \Omega$ . If the supply voltage drops by 10% with field current unaltered, then the resultant speed of the motor in RPM is \_\_\_\_\_ (Round off to the nearest integer)

**Answer:** (1343)

[Click here to watch video explanation](#)

31. For the signals  $x(t)$  and  $y(t)$  shown in the figure,  $z(t) = x(t) * y(t)$  is maximum at  $t = T_1$ . Then  $T_1$  in seconds is \_\_\_\_\_ (Round off to the nearest integer).

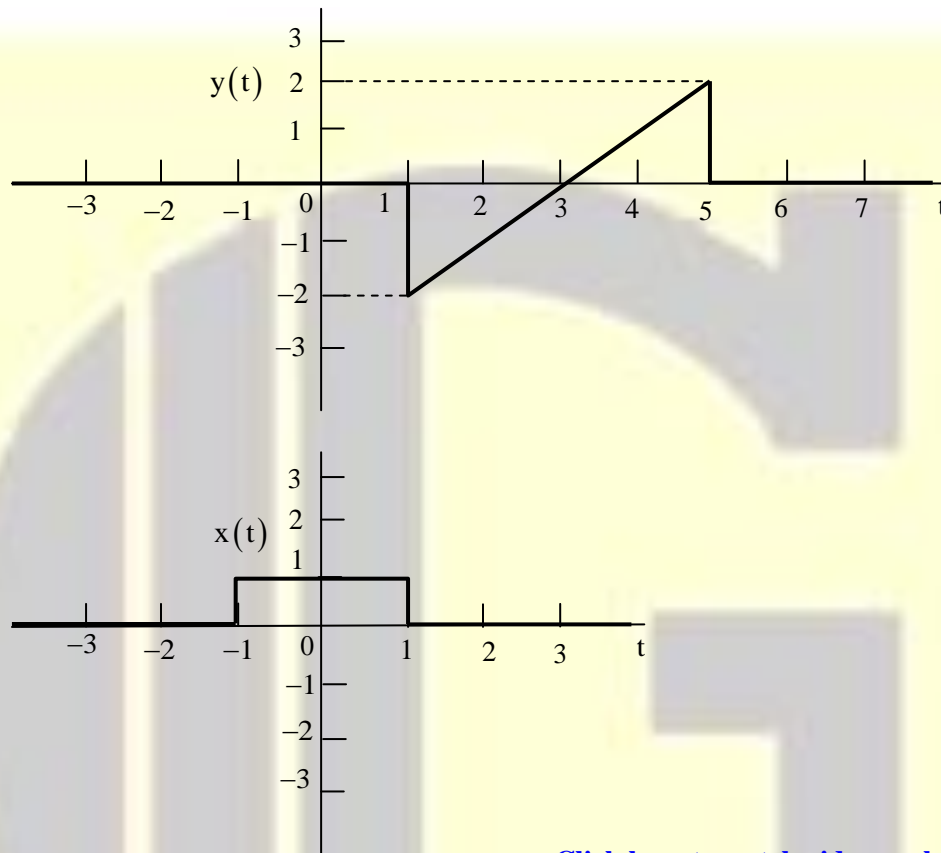

**Answer: (4)**

[Click here to watch video explanation](#)

32. For the circuit shown in the figure,  $V_1 = 8V$ , DC and  $I_1 = 8A$ , DC . The voltage  $V_{ab}$  in volts is \_\_\_\_\_ (Round off to 1 decimal place).

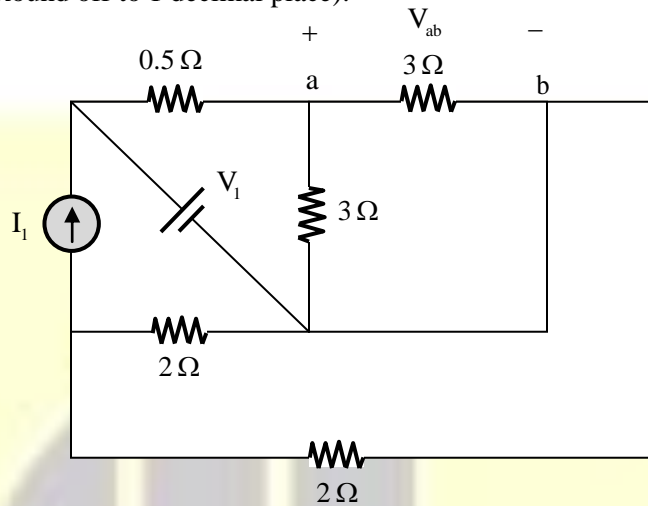

$V_1 = 8V$ , DC  
 $I_1 = 8A$ , DC

**Answer:** (6)

[Click here to watch video explanation](#)

33. A 50 Hz, 275 kV line of length 400 km has the following parameters:

Resistance,  $R = 0.035 \Omega/\text{km}$ ;

Inductance,  $L = 1 \text{ mH}/\text{km}$ ;

Capacitance,  $C = 0.01 \mu\text{F}/\text{km}$ ;

The line represented by the nominal- $\pi$  model. With the magnitude of the sending end and the receiving end voltages of the line (denoted by  $V_s$  and  $V_R$ , respectively) maintained at 275 kV, the phase angle difference ( $\theta$ ) between  $V_s$  and  $V_R$  required for maximum possible active power to be delivered to the receiving end, in degree is \_\_\_\_\_ (Round off to 2 decimal places).

**Answer:** (83.64)

[Click here to watch video explanation](#)

34. In the following differential equation, the numerically obtained value of  $y(t)$ , at  $t = 1$ , is \_\_\_\_\_ (Round off to 2 decimal places).

$$\frac{dy}{dt} = \frac{e^{-at}}{2 + at}, \quad \alpha = 0.01 \text{ and } y(0) = 0$$

**Answer:** (0.50)

[Click here to watch video explanation](#)





## *GATE REFRESHER COURSE* Electrical Engineering

**GATEFORUM** Pioneers in Digital courses for GATE since 2008 offers **GATE refresher course** giving you access to video solutions for previous 11 years GATE questions and Topic-wise formula Compendium (Handbook).

**Enroll now and get 20% discount use  
Promo Code **GATEPAPERS****

**For more details visit [gateforumonline.com](http://gateforumonline.com)**

35. Three points in the x-y plane are (-1, 0.8), (0, 2.2) and (1, 2.8). The value of the slope of the best fit straight line in the least square sense is \_\_\_\_\_ (Round off to 2 decimal places).

**Answer: (1)**

[Click here to watch video explanation](#)

**Q. No. 36-65 Carry Two Marks Each**

36. The magnitude and phase plots of an LTI system are shown in the figure. The transfer function of the system is

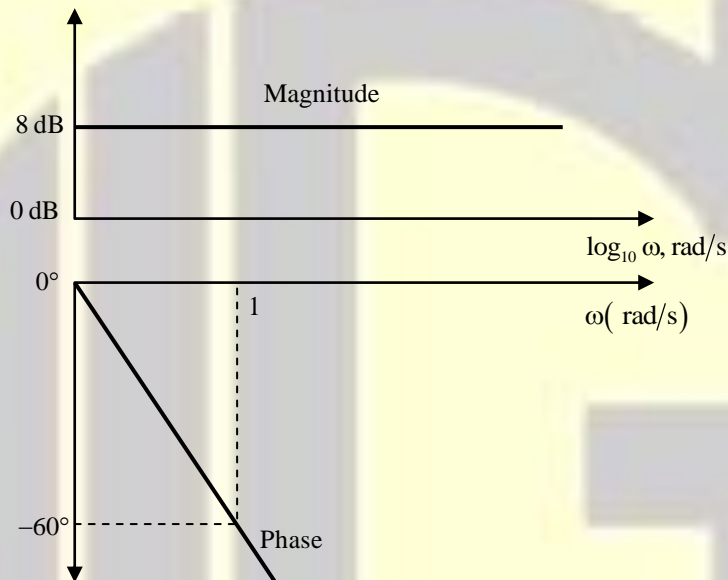

- (A)  $2.51e^{-0.032s}$       (B)  $\frac{e^{-2.514s}}{s+1}$       (C)  $1.04e^{-2.514s}$       (D)  $2.51e^{-1.047s}$

**Answer: (D)**

[Click here to watch video explanation](#)

37. Consider the OP AMP based circuit shown in the figure. Ignore the conduction drops of diodes  $D_1$  and  $D_2$ . All the components are ideal and the breakdown voltage of the Zener is 5 V. Which of the following statements is true?

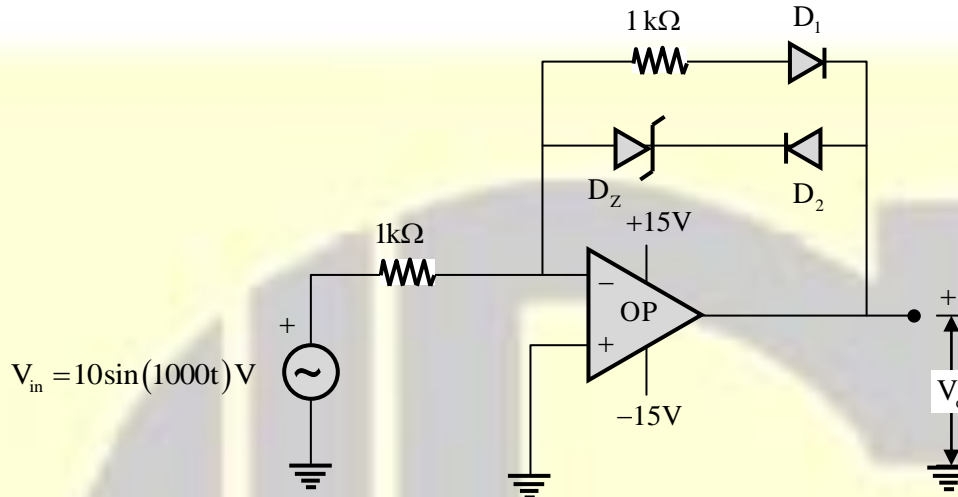

- (A) The maximum and minimum values of the output voltage  $V_o$  are +15 V and -10 V, respectively.  
 (B) The maximum and minimum values of the output voltage  $V_o$  are +5 V and -15 V, respectively.  
 (C) The maximum and minimum values of the output voltage  $V_o$  are +10 V and -5 V, respectively.  
 (D) The maximum and minimum values of the output voltage  $V_o$  are +5 V and -10 V, respectively.

**Answer: (D)**

[Click here to watch video explanation](#)

38. Consider a lead compensator of the form

$$K(s) = \frac{1 + \frac{s}{a}}{1 + \frac{s}{\beta a}}, \beta > 1, a > 0$$

The frequency at which this compensator produces maximum phase lead is 4 rad/s. At this frequency, the gain amplification provided by the controller, assuming asymptotic Bode-magnitude plot of  $K(s)$ , is 6 dB. The values of  $a, \beta$ , respectively are

- (A) 1, 16                      (B) 2, 4                      (C) 3, 5                      (D) 2.66, 2.25

**Answer: (B)**

[Click here to watch video explanation](#)

39. A 3-phase, star-connected, balanced load is supplied from a 3-phase, 400 V (rms), balanced voltage source with phase sequence R-Y-B, as shown in the figure. If the wattmeter reading is  $-400\text{ W}$  and the line current is  $I_R = 2\text{ A}$  (rms), then the power factor of the load per phase is

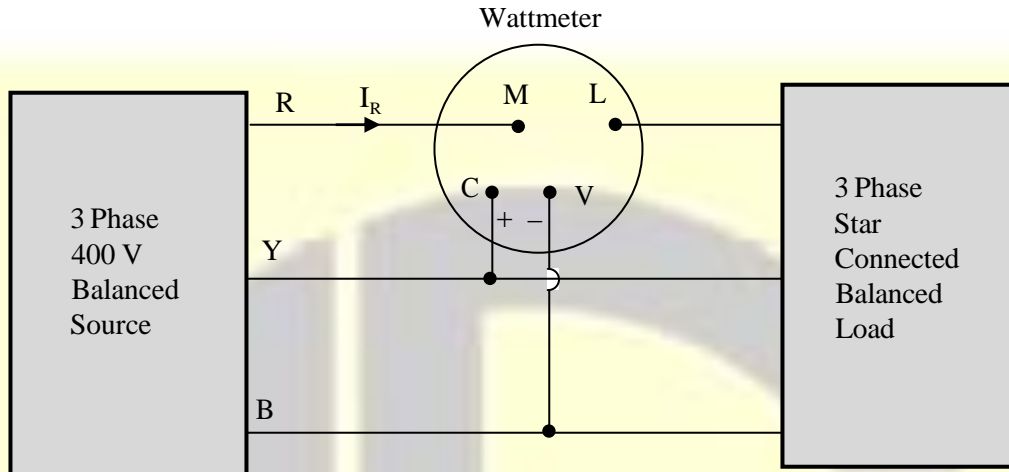

- (A) Unity      (B) 0.5 leading      (C) 0.866 leading      (D) 0.707 lagging

**Answer: (C)**

[Click here to watch video explanation](#)

40. An 8 bit ADC converts analog voltage in the range of 0 to +5 V to the corresponding digital code as per the conversion characteristics shown in figure. For  $V_{in} = 1.9922\text{ V}$ , which of the following digital output, given in hex, is true?

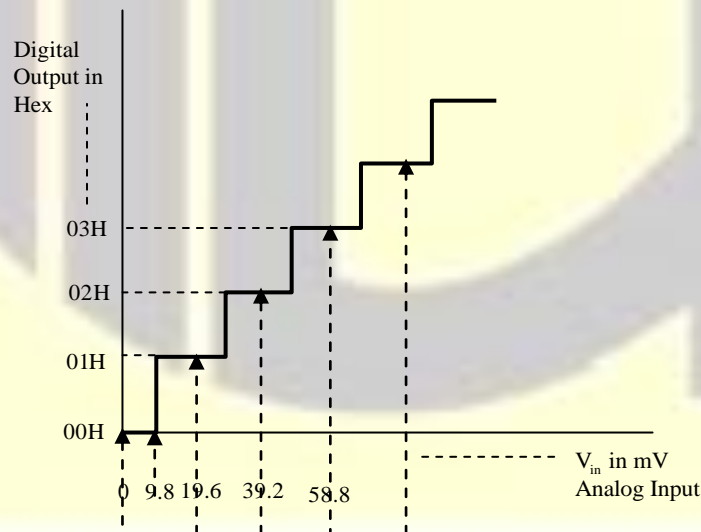

- (A) 64H      (B) 65H      (C) 66H      (D) 67H

**Answer: (C)**

[Click here to watch video explanation](#)

41. The three-bus power system shown in the figure has one alternator connected to bus 2 which supplies 200 MW and 40 MVAR power. Bus 3 is infinite bus having a voltage of magnitude  $|V_3| = 1.0$  p.u. and angle of  $-15^\circ$ . A variable current source,  $|I| \angle \phi$  is connected at bus 1 and controlled such that the magnitude of the bus 1 voltage is maintained at 1.05 p.u. and the phase angle of the source current,  $\phi = \theta_1 \pm \frac{\pi}{2}$ , where  $\theta_1$  is the phase angle of the bus 1 voltage. The three buses can be categorized for load flow analysis as

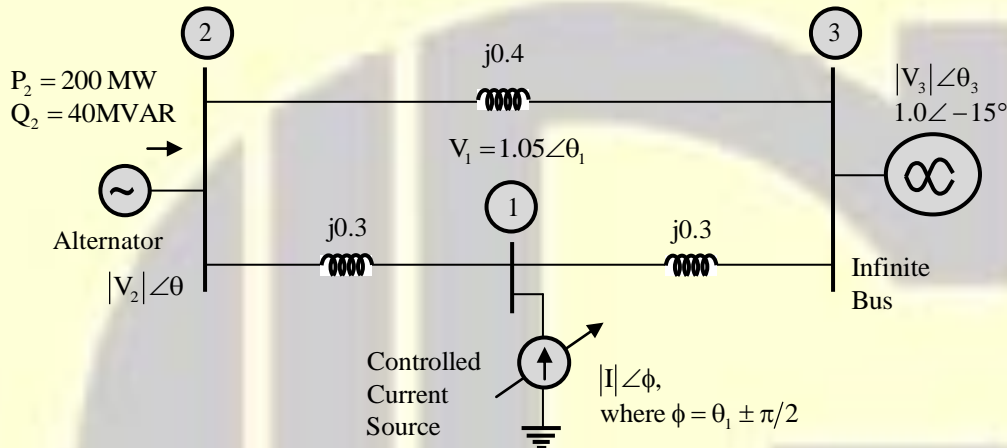

- |                     |                     |
|---------------------|---------------------|
| (A) Bus 1 Slack bus | (B) Bus 1 P- V  bus |
| Bus 2 P- V  bus     | Bus 2 P- V  bus     |
| Bus 3 P-Q bus       | Bus 3 Slack bus     |
| (C) Bus 1 P-Q bus   | (D) Bus 1 P- V  bus |
| Bus 2 P-Q bus       | Bus 2 P-Q bus       |
| Bus 3 Slack bus     | Bus 3 Slack bus     |

**Answer: (D)**

[Click here to watch video explanation](#)

42. Consider the following equation in a 2-D real-space

$$|x_1|^p + |x_2|^p = 1 \text{ for } p > 0$$

Which of the following statement(s) is/are true.

- (A) When  $p = 2$ , the area enclosed by the curve is  $\pi$ .
- (B) When  $p$  tends to  $\infty$ , the area enclosed by the curve tends to 4.
- (C) When  $p$  tends to 0, the area enclosed by the curve is 1.
- (D) When  $p = 1$ , the area enclosed by the curve is 2.

**Answer: (A, D)**

[Click here to watch video explanation](#)

43. In the figure, the electric field  $E$  and the magnetic field  $B$  point to  $x$  and  $z$  directions, respectively, and have constant magnitudes. A positive charge 'q' is released from rest at the origin. Which of the following statement(s) is/are true.



- (A) The charge will move in the direction of  $z$  with constant velocity.
- (B) The charge will always move on the  $y-z$  plane only.
- (C) The trajectory of the charge will be a circle.
- (D) The charge will progress in the direction of  $y$ .

**Answer:** (\*) (MTA)

[Click here to watch video explanation](#)

44. All the elements in the circuit shown in the following figure are ideal. Which of the following statements is/are true?

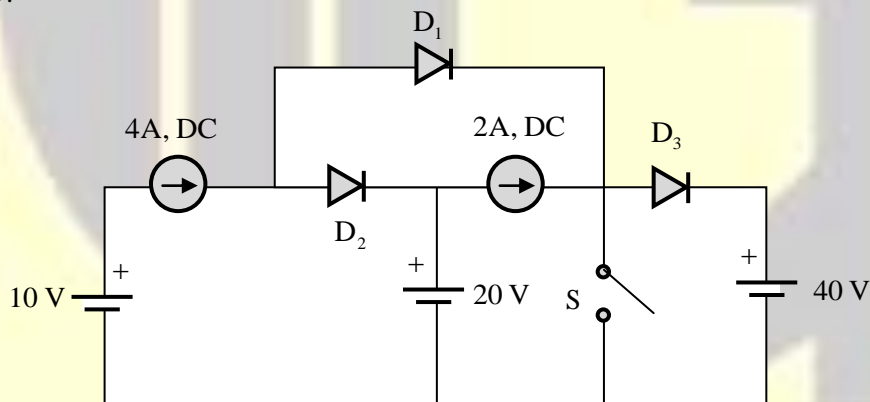

- (A) When switch  $S$  is ON, both  $D_1$  and  $D_2$  conducts and  $D_3$  is reverse biased
- (B) When switch  $S$  is ON,  $D_1$  conducts and both  $D_2$  and  $D_3$  are reverse biased
- (C) When switch  $S$  is OFF,  $D_1$  is reverse biased and both  $D_2$  and  $D_3$  conduct
- (D) When switch  $S$  is OFF,  $D_1$  conducts,  $D_2$  is reverse biased and  $D_3$  conducts

**Answer:** (B, C)

[Click here to watch video explanation](#)

45. The expected number of trials for first occurrence of a “head” in a biased coin is known to be 4. The probability of first occurrence of a “head” in the second trial is \_\_\_\_\_ (Round off to 3 decimal places).

**Answer: (0.188)**

[Click here to watch video explanation](#)

46. Consider the state-space description of an LTI system with matrices

$$A = \begin{bmatrix} 0 & 1 \\ -1 & -2 \end{bmatrix}, B = \begin{bmatrix} 0 \\ 1 \end{bmatrix}, C = [3 \quad -2], D = 1$$

For the input,  $\sin(\omega t)$ ,  $\omega > 0$ , the value of  $\omega$  for which the steady-state output of the system will be zero, is \_\_\_\_\_ (Round off to the nearest integer).

**Answer: (2)**

[Click here to watch video explanation](#)

47. A three-phase synchronous motor with synchronous impedance of  $0.1 + j0.3$  per unit per phase has a static stability limit of 2.5 per unit. The corresponding excitation voltage in per unit is \_\_\_\_\_ (Round off to 2 decimal places).

**Answer: (1.60)**

[Click here to watch video explanation](#)

48. A three phase 415 V, 50 Hz, 6-pole, 960 RPM, 4 HP squirrel cage induction motor drives a constant torque load at rated speed operating from rated supply and delivering rated output. If the supply voltage and frequency are reduced by 20%, the resultant speed of the motor in RPM (neglecting the stator leakage impedance and rotational losses) is \_\_\_\_\_ (Round off to the nearest integer).

**Answer: (760)**

[Click here to watch video explanation](#)

49. The period of the discrete-time signal  $x[n]$  described by the equation below is  $N =$  \_\_\_\_\_ (Round off to the nearest integer).

$$x[n] = 1 + 3\sin\left(\frac{15\pi}{8}n + \frac{3\pi}{4}\right) - 5\sin\left(\frac{\pi}{3}n - \frac{\pi}{4}\right)$$

**Answer: (48)**

[Click here to watch video explanation](#)

50. The discrete-time Fourier transform of a signal  $x[n]$  is  $X(\Omega) = (1 + \cos \Omega)e^{-j\Omega}$ . Consider that  $x_p[n]$  is a periodic signal of period  $N = 5$  such that

$$x_p[n] = x[n], \text{ for } n = 0, 1, 2$$

$$= 0, \text{ for } n = 3, 4$$

Note that  $x_p[n] = \sum_{k=0}^{N-1} a_k e^{j\frac{2\pi}{N}kn}$ . The magnitude of the Fourier series coefficient  $a_3$  is \_\_\_\_\_ (Round off to 3 decimal places).

**Answer:** (0.038)

[Click here to watch video explanation](#)

51. For the circuit shown, if  $i = \sin 1000t$ , the instantaneous value of the Thevenin's equivalent voltage (in Volts) across the terminal a-b at time  $t = 5$  ms is \_\_\_\_\_ (Round off to 2 decimal places).

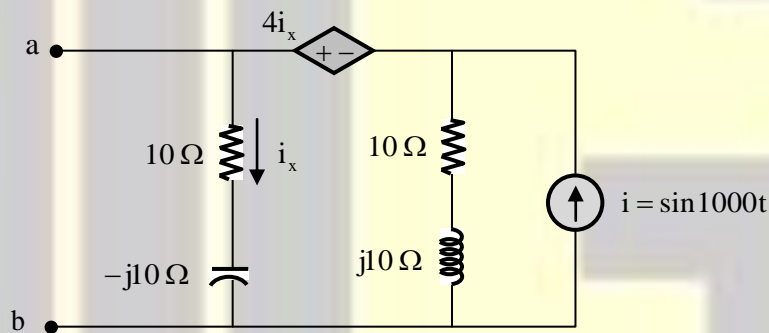

**Answer:** (-11.38)

[Click here to watch video explanation](#)



52. The admittance parameters of the passive resistive two-port network shown in the figure are

$$y_{11} = 5\text{S}, y_{22} = 1\text{S}, y_{12} = y_{21} = -2.5\text{S}$$

The power delivered to the load resistor  $R_L$  in Watt is \_\_\_\_\_ (Round off to 2 decimal places).

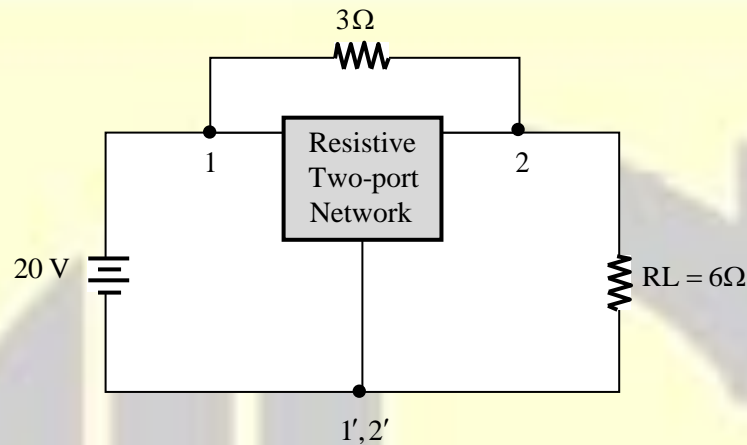

**Answer:** (237.86)

[Click here to watch video explanation](#)

53. When the winding c-d of the single-phase, 50 Hz, two winding transformer is supplied from an AC current source of frequency 50 Hz, the rated voltage of 200 V (rms), 50 Hz is obtained at the open-circuited terminals a-b. The cross sectional area of the core is  $5000 \text{ mm}^2$  and the average core length traversed by the mutual flux is 500 mm. The maximum allowable flux density in the core is  $B_{\text{max}} = 1 \text{ Wb/m}^2$  and the relative permeability of the core material is 5000. The leakage impedance of the winding a-b and winding c-d at 50 Hz are  $(5 + j100\pi \times 0.16)\Omega$  and  $(11.25 + j100\pi \times 0.36)\Omega$ , respectively. Considering the magnetizing characteristics to be linear and neglecting core loss, the self-inductance of the winding a-b in millihenry is \_\_\_\_\_ (Round off to 1 decimal place).

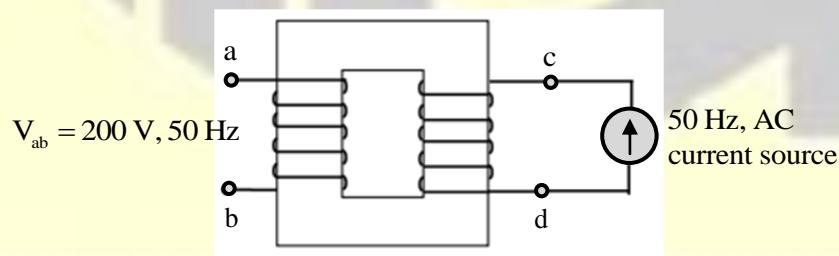

**Answer:** (2058.43)

[Click here to watch video explanation](#)

54. The circuit shown in the figure is initially in the steady state with the switch  $K$  in open condition and  $\bar{K}$  in closed condition. The switch  $K$  is closed and  $\bar{K}$  is opened simultaneously at the instant  $t = t_1$ , where  $t_1 > 0$ . The minimum value of  $t_1$  in milliseconds, such that there is no transient in the voltage across the  $100 \mu\text{F}$  capacitor, is \_\_\_\_\_ (Round off to 2 decimal places).

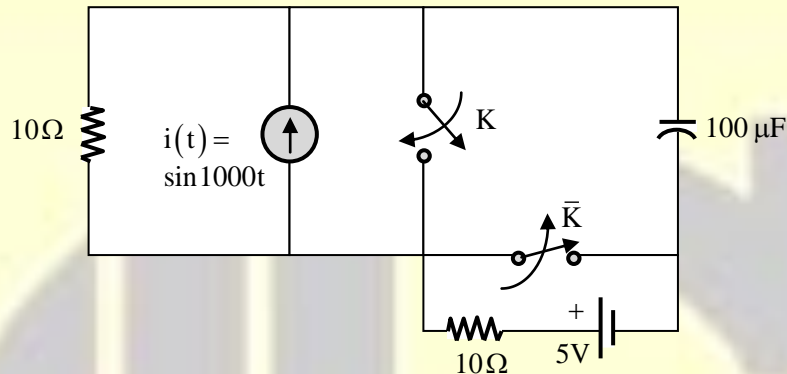

**Answer: (1.57)**

[Click here to watch video explanation](#)

55. The circuit shown in the figure has reached steady state with thyristor 'T' in OFF condition. Assume that the latching and holding currents of the thyristor are zero. The thyristor is turned ON at  $t = 0$  sec. The duration in microseconds for which the thyristor would conduct, before it turns off, is \_\_\_\_\_ (Round off to 2 decimal places).

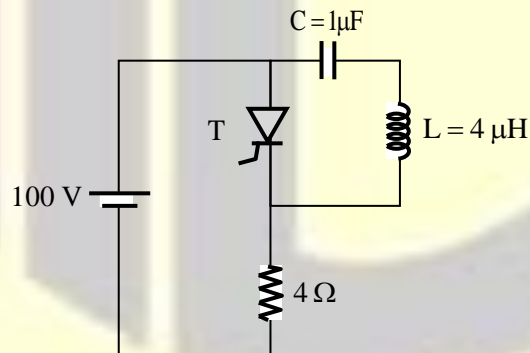

**Answer: (7.33)**

[Click here to watch video explanation](#)

56. Neglecting the delays due to the logic gates in the circuit shown in figure, the decimal equivalent of the binary sequence [ABCD] of initial logic states, which will not change with clock, is \_\_\_\_\_.

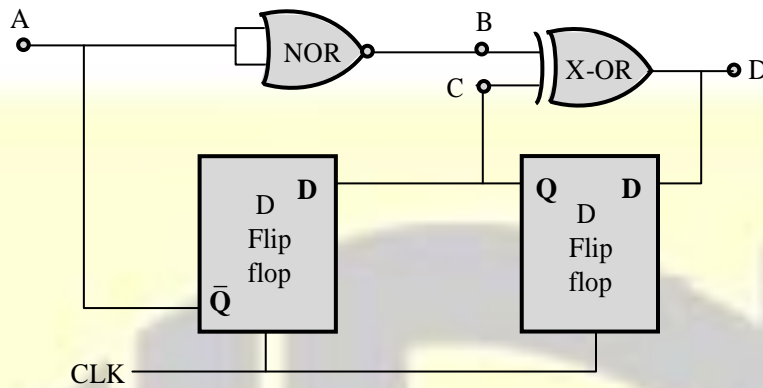

**Answer: (8)**

[Click here to watch video explanation](#)

57. In a given 8-bit general purpose micro-controller there are following flags.  
C-Carry, A-Auxiliary Carry, O-Overflow flag, P-Parity (0 for even, 1 for odd)  
R0 and R1 are the two general purpose registers of the micro-controller.  
After execution of the following instructions, the decimal equivalent of the binary sequence of the flag pattern [CAOP] will be \_\_\_\_\_.
- MOV R0, +0x60  
MOV R1, +0x46  
ADD R0, R1

**Answer: (0)**

[Click here to watch video explanation](#)

58. The single phase rectifier consisting of three thyristors  $T_1, T_2, T_3$  and a diode  $D_1$  feed power to a 10 A constant current load.  $T_1$  and  $T_3$  are fired at  $\alpha = 60^\circ$  and  $T_2$  is fired at  $\alpha = 240^\circ$ . The reference for  $\alpha$  is the positive zero crossing of  $V_{in}$ . The average voltage  $V_o$  across the load in volts is \_\_\_\_\_ (Round off to 2 decimal places).

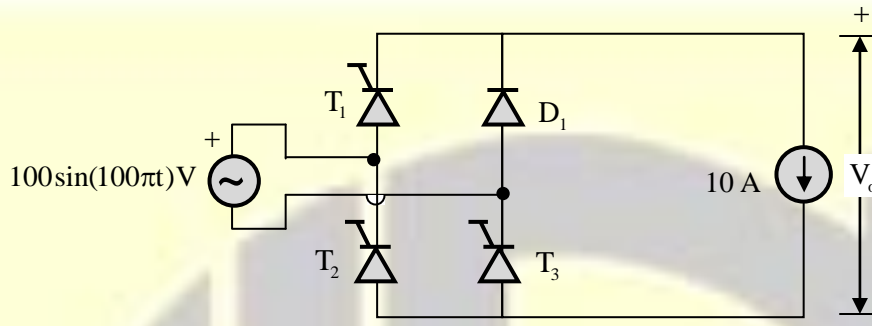

**Answer: (39.78)**

[Click here to watch video explanation](#)

59. The Zener diode in circuit has a breakdown voltage of 5V. The current gain  $\beta$  of the transistor in the active region is 99. Ignore base-emitter voltage drop  $V_{BE}$ . The current through the  $20\Omega$  resistance in milliamperes is \_\_\_\_\_ (Round off to 2 decimal places).

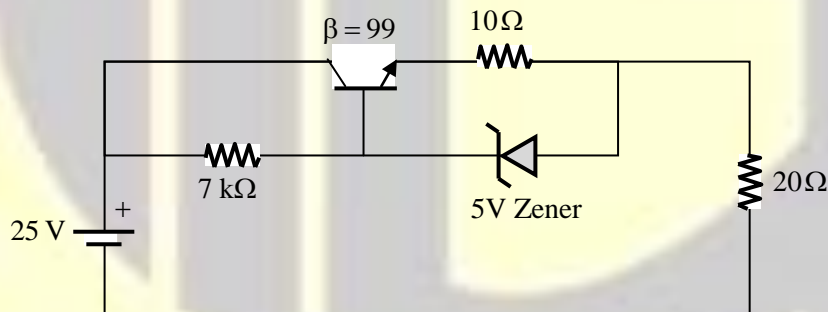

**Answer: (250)**

[Click here to watch video explanation](#)

60. The two-bus power system shown in figure (i) has one alternator supplying a synchronous motor load through a Y- $\Delta$  transformer. The positive, negative and zero-sequence diagrams of the system are shown in figures (ii), (iii) and (iv), respectively. All reactances in the sequence diagrams are in p.u. For a bolted lineto-line fault (fault impedance = zero) between phases 'b' and 'c' at bus 1, neglecting all pre-fault currents, the magnitude of the fault current (from phase 'b' to 'c') in p.u. is \_\_\_\_\_ (Round off to 2 decimal places).

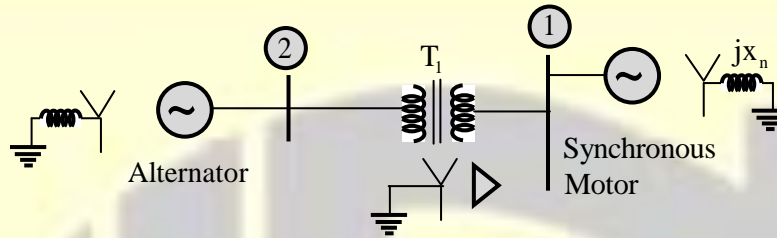

Figure (i) : Single-line diagram of the power system

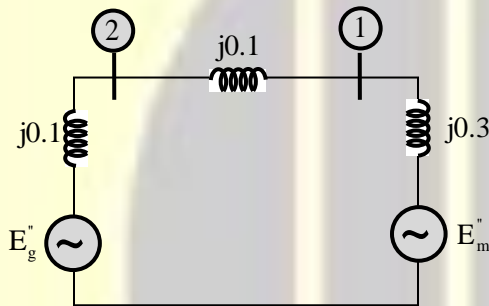

Figure (ii) : Positive-sequence network

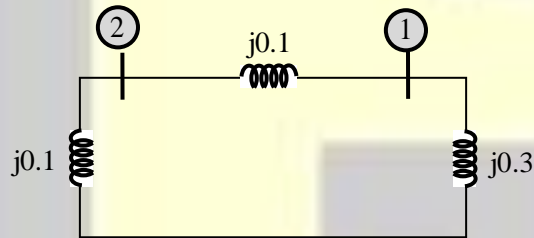

Figure (iii) : Negative-sequence network

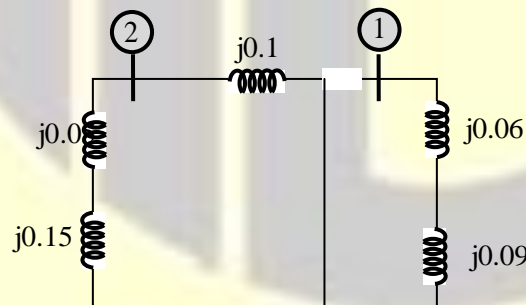
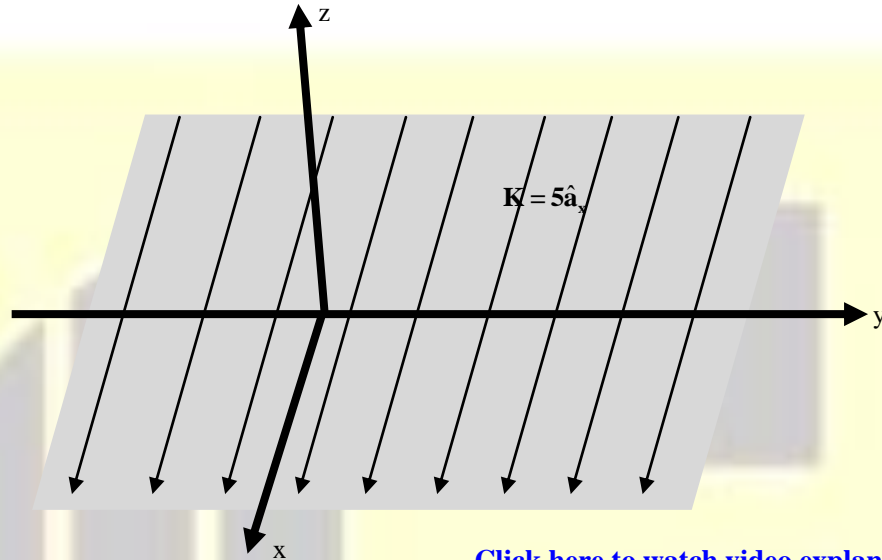

Figure (iv) : Zero-sequence network

**Answer: (7.21)**

[Click here to watch video explanation](#)

61. An infinite surface of linear current density  $K = 5\hat{a}_x$  A/m exists on the x-y plane, as shown in the figure. The magnitude of the magnetic field intensity (H) at a point (1,1,1) due to the surface current in Ampere/meter is \_\_\_\_\_ (Round off to 2 decimal places).



**Answer: (2.5)**

[Click here to watch video explanation](#)

62. The closed curve shown in the figure is described by  $r = 1 + \cos \theta$ , where  $r = \sqrt{x^2 + y^2}$ ;  $x = r \cos \theta$ ,  $y = r \sin \theta$ . The magnitude of the line integral of the vector field  $F = -y\hat{i} + x\hat{j}$  around the closed curve is \_\_\_\_\_ (Round off to 2 decimal places).

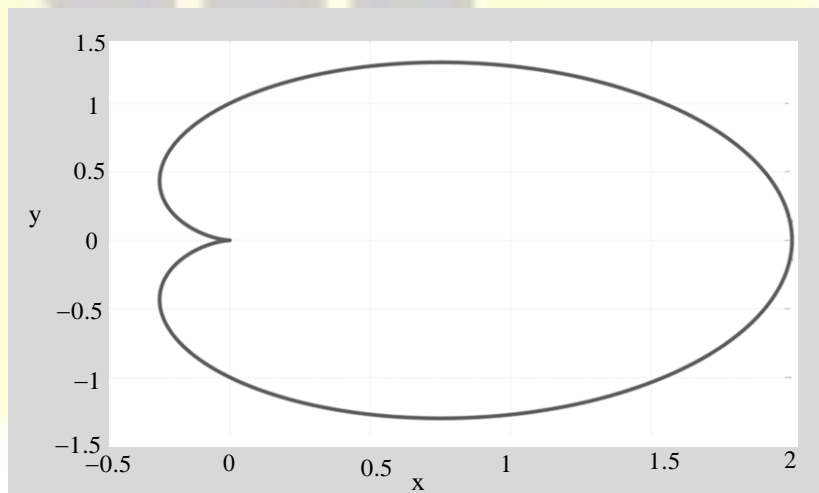

**Answer: (9.42)**

[Click here to watch video explanation](#)

63. A signal  $x(t) = 2\cos(180\pi t)\cos(60\pi t)$  is sampled at 200 Hz and then passed through an ideal low pass filter having cut-off frequency of 100 Hz. The maximum frequency present in the filtered signal in Hz is \_\_\_\_\_ (Round off to the nearest integer)

**Answer: (80)**

[Click here to watch video explanation](#)

64. A balanced delta connected load consisting of the series connection of one resistor ( $R = 15\ \Omega$ ) and a capacitor ( $C = 212.21\ \mu\text{F}$ ) in each phase is connected to three phase, 50 Hz, 415 V supply terminals through a line having an inductance of  $L = 31.83\ \text{mH}$  per phase, as shown in the figure. Considering the change in the supply terminal voltage with loading to be negligible, the magnitude of the voltage across the terminals  $V_{AB}$  in Volts is \_\_\_\_\_ (Round off to the nearest integer).

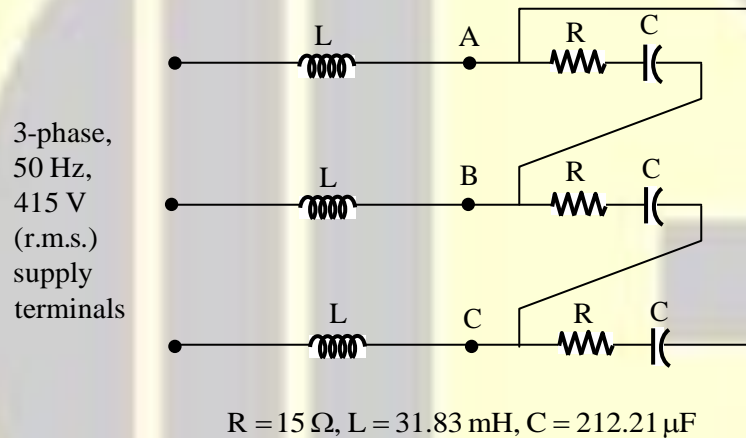

**Answer: (415)**

[Click here to watch video explanation](#)

65. A quadratic function of two variables is given as

$$f(x_1, x_2) = x_1^2 + 2x_2^2 + 3x_1 + 3x_2 + x_1x_2 + 1$$

The magnitude of the maximum rate of change of the function at the point (1, 1) is \_\_\_\_\_ (Round off to the nearest integer).

**Answer: (10)**

[Click here to watch video explanation](#)





Follow us @



For more details visit [gateforumonline.com](http://gateforumonline.com)