

# CIVIL ENGINEERING

## PAPER-II

Time Allowed: **Three Hours**

Maximum Marks: **300**

---

### **Question Paper Specific Instructions**

**Please reach each of the following instruction carefully before attempting questions:**

There are **EIGHT** questions divided in **TWO** sections.

Candidate has to attempt **FIVE** questions in all

Questions **No.1** and **5** are **compulsory** and out of the remaining, any **THREE** are to be attempted choosing at least **ONE** question from each section.

The number of marks carried by a question/part is indicated against it.

Wherever any assumptions are made for answering a question, they must be clearly indicated.

Diagrams/figures, wherever required, shall be drawn in the space provided for answering the question itself.

Unless otherwise mentioned, symbols and rotations carry their usual standard meanings.

Attempts of questions shall be counted in sequential order. Unless struck off, attempt of a question shall be counted even if attempted partly.

Any page or portion of the page left blank in the QCA Booklet must be clearly struck off.

Answers must be written in **ENGLISH** only.

---

**SECTION-A**

1. (a) The annual rainfall of six different raingauge stations of a river basin is 136.70 cm, 102.90 cm, 98.80 cm, 180.30 cm, 82.60 cm and 110.30 cm.

Determine:

- (i) The standard error in the estimation of average rainfall of the six raingauge stations.  
(ii) The optimum number of raingauge stations in the river basin for a 10% error in the estimation of average rainfall.

[12 Marks]

- (b) A 1.3 m wide rectangular channel had 0.35 m depth of water at a certain section of the channel. The flow discharge through the channel is 2.0 cumecs. Determine whether the hydraulic jump will take place or not. Find the height of jump and loss of energy.

[12 Marks]

- (c) Find out the power required to drive the centrifugal pump if it lifts water to a height of 22 m. The overall efficiency of the pump is 70%. The pipe diameter is 10 cm and length is 100 m. It delivers 1500 l/min as discharge with the coefficient of friction of pipe as 0.004 and  $\gamma$  as  $\rho g$  ( $1000 \times 9.81$ )

[12 Marks]

- (d) A PST 15 m long, 6 m wide and 3 m deep treats water for a town with a population of 20,000 supplied with 100 lpcd. The raw water sample indicated suspended solids conc. as 60 ppm. The PST worked with efficiency of 70% SS removal and the average specific gravity of the deposit in PST was 2.6. Compute

- (i) Detention Time  
(ii) Horizontal Velocity  
(iii) Rate of dry solids deposited  
(iv) Overflow rate

[12 Marks]

- (e) Discuss the impact of heavy metals in industrial wastewater when disposed into surface water. With the help of sketches, explain the working principle of the two methods used for removal of heavy metal from industrial wastewater.

[12 Marks]

2. (a) (i) Define the “dilution method” of flow measurement by sudden injection and constant injection of chemicals in flowing water with diagram and governing equations.

(ii) A Rhodamine dye solution was discharged in a river section at a constant rate. Estimate the discharge if the dye is found to reach an equilibrium of 5 parts per billion (ppb).

Given : Amount of Rhodamine Dye = 25 g/ℓ

Constant rate of flow: 10 cm<sup>3</sup>/s

Assume  $C_o = 0$

[10 + 10 Marks]

(b) A city with population of 5 lakhs is to be supplied water @ 150 lpcd.

Using the data given below, determine the storage capacity of the reservoir assuming

(i) Continuous pumping

(ii) Pumping for 9 hours from 6 PM – 3 AM

Also assume fire demand @ 2 lpcd and power breakdown for 2 hours.

0-3AM – 5% of total

3-6AM – 5% of total

6-9AM – 40% of total

9-12 PM – 10% of total

12-3PM – 5% of total

3-6PM – 10% of total

6-9PM – 20% of total

9-12AM – 5% of total

[20 Marks]

(c) Differentiate between Symbiosis and Parasitism relationship. Explaining the working principles of oxidation ponds, discuss the importance of Algal-Bacteria symbiosis relationship in oxidation ponds.

[12 Marks]

3. (a) Referring to figure 1, calculate the discharge from the well in steady state condition. The well completely penetrates the confined aquifer.

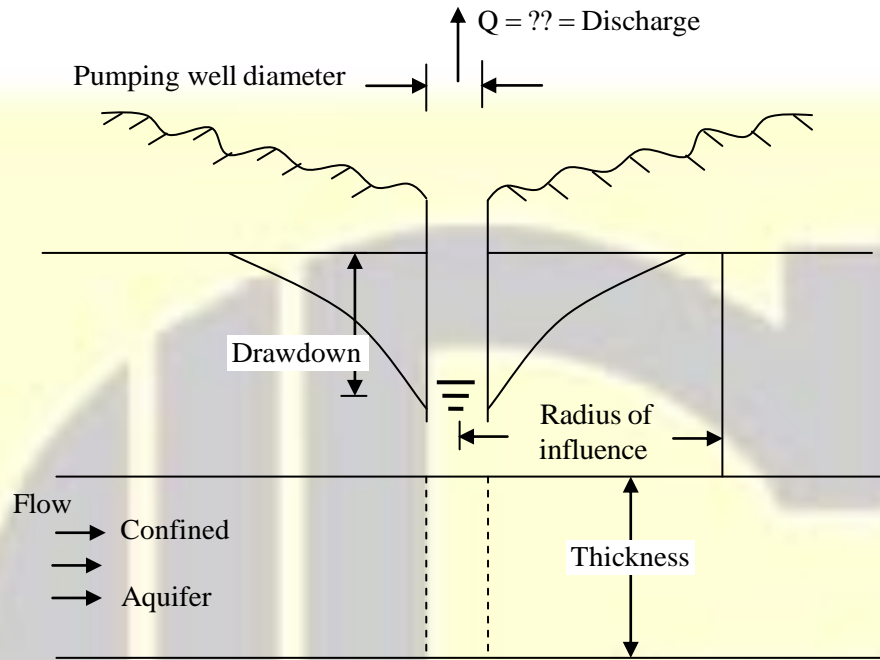

Figure 1

Given:

Diameter of pumping well = 30 cm

Permeability = 45 m/day

Length of the strainer = 20 m

Drawdown = 3.0 m

Radius of influence = 300 m

Discharge = ??

[20 Marks]

- (b) Find the discharge of water through the pipe, the velocity of venturimeter throat and the pressure 600 cm above the venturimeter using Bernoulli's theorem. Given:

Diameter of vertical pipe = 15 cm

Venturimeter throat = 7 cm

Absolute pressure at throat = 1 atm

Pressure at 600 cm below the venturimeter = 5 atm

[20 Marks]

- (c) With the help of sketches, explain the effect of lapse rate on plume behaviour indicating the possible plume shapes and dispersion conditions.

[20 Marks]

4. (a) Calculate (i) total installed capacity of turbo generators, (ii) load factor, (iii) plant factor, and (iv) utilization factor of three generators of a hydel power station, each having a capacity of 10000 kW. The load of the plant varies from 12000 kW to 26000 kW.

[20 Marks]

- (b) The MLSS concentration in an aeration tank of ASP system was 3000 mg/L. Sludge volume was 180 mL after 30 minutes of settling in 1000 mL graduated measuring jar. For the above sample, find
- (i) SVI
  - (ii) SDI
  - (iii) Return sludge ratio required
  - (iv) SS cone. in recirculated sludge

[20 Marks]

- (c) Using the data given below, find the moisture content (Wet and dry basis) of the municipal solid waste. Also estimate the as-discarded density. If the compaction is 3, find the size of collection vehicle required for 1000 kg of MSW.

S.No.	Waste Component	Mass(%)	MC (%)	Density (kg/m <sup>3</sup> )
1	Newspaper	15	6	85
2.	Other paper	24	6	85
3.	Cardboard	33	5	50
4.	Glass	4.2	0.5	195
5.	Plastic	0.49	2	65
6.	Aluminium	0.13	0.5	160
7.	Iron	1.18	0.5	320
8.	Non-ferrous	0.35	0.5	160
9.	Yard wastes	17.97	60	105
10.	Food wastes	1.67	60	290
11.	Soil and dust	2.01	8	480

[20 Marks]

**SECTION-B**

5. (a) A 6 m high pier rests on a 2 m x 2 m square footing at 1.5 m depth from the surface at a site having uniform clayey soils. The unconfined compressive strength of the clay is 100 kPa and its bulk unit weight is  $20 \text{ kN/m}^3$ . The pier carries a vertical load of 80 kN at the centre including its self-weight. A resultant horizontal load of 15 kN also acts on one side of the pier at 1.5 m above the surface. Determine the factor of safety with respect to the pier's net ultimate bearing capacity as per IS 6403 recommendations.

[12 Marks]

---

- (b) An electric power transmission pole is embedded 3 m into the ground. The pole weighs 30 kN and has base diameter of 450 mm. If the pole is assumed to transmit the load as point load in the soil, determine the stress increase at a depth 1 m below the base, and :
- (i) Along the centre, and  
(ii) 1 m from the centre

[12 Marks]

---

- (c) What are the key factors considered in the modernization of railway track with the aim to increase the average speed and capacity of the modernized section?

[12 Marks]

---

- (d) A car moving with a speed of 80 kmph has to overtake another car moving at a speed of 64 kmph in the two-lane one-way highway. If the reaction time of the driver is 2.5 s and acceleration of overtaking car is  $0.95 \text{ m/s}^2$ , calculate the safe overtaking sight distance.

[12 Marks]

---

- (e) In running fly levels from a benchmark of reduced level 212.40 m, a surveyor took an intermediate sight of 0.420 m with the staff held on a benchmark of reduced level 264.005 m. The sum of Back Sights and Fore Sights from the start to second BM is 75.205 m and 23.450 m, respectively. What is the closing error on the second benchmark? If the distance between the first BM and second BM is 30 km, comment whether the work is satisfactory for ordinary leveling for location and construction survey or not.

[12 Marks]

---

6. (a) (i) An embankment is to be constructed using sandy clay compacted to dry unit weight of  $18 \text{ kN/m}^3$ . The sandy clay has to be transported to the site from a borrow pit. The bulk unit weight of the sandy clay in the borrow pit is  $16 \text{ kN/m}^3$  and its natural water content is 11%. Calculate the volume of sandy clay from the borrow pit required for 1 cubic metre of finished embankment.
- Assume that the soil swells by 10% due to excavation and during transportation. You can take  $G_s = 2.7$ .
- (ii) A 1.2 m thick embankment of loose sand is to be compacted using a Vibratory Roller. If the void ratio decreases from 1.2 to 0.8 due to compaction, calculate the final thickness of the embankment.

[12 + 8 Marks]

- (b) Soil sample and flow conditions are shown in the following figure:

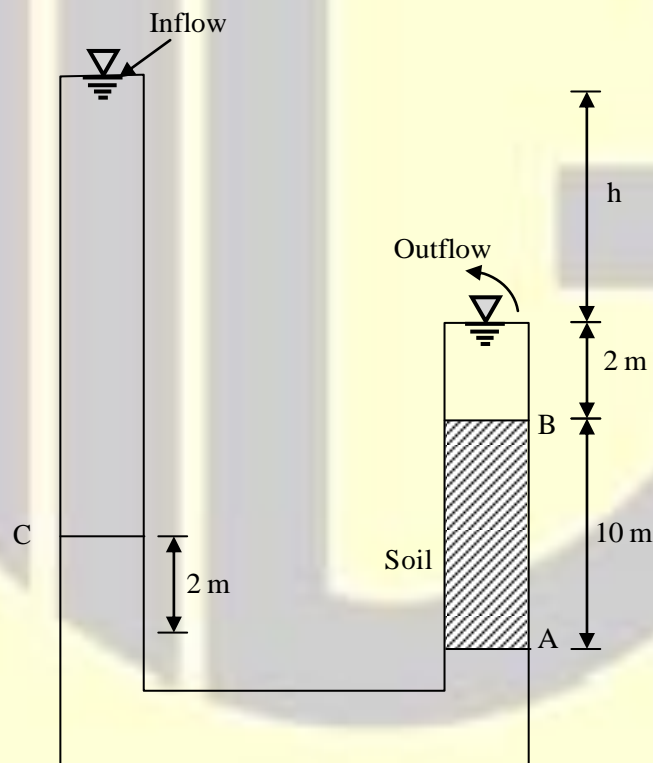

$$\gamma_{\text{sat}} \text{ of sand} = 20 \text{ kN/m}^3$$

$$\gamma_w = 10 \text{ kN/m}^3$$

Figure not to scale

- (i) Find the head,  $h$  required to cause quick condition.
- (ii) Compute the seepage force per unit volume at quick condition.

Use cross-section area of tube as  $1 \text{ m}^2$ .

- (iii) A student accidentally broke the left hand riser tube to the point C at an elevation 2 m above point A. Assuming that the water level is now maintained at C, compute the new hydraulic gradient, effective stress at elevation A and seepage force at elevation A.

[20 Marks]

- (c) (i) Elaborate the various criteria which need to be considered for selection of site of a civilian greenfield airport in the hilly region.

- (ii) Discuss the essential features of an ideal commercial harbour.

[15 + 5 Marks]

7. (a) A simple circular curve is to set out in a National Highway touching the three lines having following details:

Line	Reduced Bearing	Length (m)
AB	N $90^\circ$ E	–
BC	S $0^\circ$ E	170
CD	S $70^\circ$ W	–

If the chainage of point B is 700 m, calculate the radius of curve and chainage of all the tangent points in the curve.

[20 Marks]

- (b) (i) A long trench with vertical sides is to be excavated in soft saturated clay deposits  $\phi_u = 0$  to lay a sewage pipeline. If the maximum depth of the trench is 2 m, what should be the approximate undrained cohesion of the clay ( $C_u$ ) to maintain a minimum safety factor of 3? Assume that the clay has a unit weight of  $20 \text{ kN/m}^3$  and that the groundwater table is sufficiently below the excavation depth.

- (ii) A clay has plastic limit and liquid limit of 18 and 39 percent, respectively. What water content would correspond to its liquidity index of - 0.1? Comment on the consistency of this clay.

[10 + 10 Marks]



- (c) A prestressed concrete pipe of 0.5 m diameter is driven in medium dense sand up to 10 m depth. The groundwater table level is at 3 m depth below the surface. The properties of the sand are:

Angle of internal friction of sand, $\phi'$	30 degrees
Angle of wall friction between pile and sand, $\delta$	20 degrees
Post-driving horizontal earth pressure co-efficient	1
Saturated unit weight of sand	19 kN/m <sup>3</sup>
Unit weight of sand above groundwater table	17 kN/m <sup>3</sup>

If the unit shaft resistance reaches a limiting value at 15 D, where D is the diameter of the pile, estimate the skin friction resistance of the pile.

[20 Marks]

8. (a) (i) A 600 mm diameter pile is installed up to the bottom of a 16 m thick stiff clayey soil. The pile rests on dense gravelly strata. The average undrained shear strength of the clay is 60 kPa ( $\phi_u = 0$ ) and its saturated unit weight is 18 kN/m<sup>3</sup>. If the pile has an enlarged base of diameter 1.2 m, determine its ultimate uplift capacity. Assume that the groundwater level is at the ground surface. Ignore the benefit due to the weight of the pile. Take adhesion factor  $\alpha = 0.8$  and friction coefficient in uplift  $K = 0.5$ .
- (ii) A single-storeyed structure is to be constructed at a site in which construction debris has been dumped down to a depth of 3 m over a period of time. The debris is in loose state and consists of concrete lumps, broken tiles and brickbats mixed with soil. Describe how to proceed to find a solution for design and construction of foundation without basement.

[12 + 8 Marks]

- (b) Spot speed study was carried out to redesign the stretch of major district road. The data collected during the study is given below.

Speed Range kmph	Frequency of Vehicles		
	Two Wheelers	Cars	Others
0–10	5	0	0
10–20	20	6	4
20–30	24	12	4
30–40	20	30	5
40–50	30	60	30
50–60	35	35	30
60–70	25	35	15
70–80	10	15	10
80–90	10	18	2
90–100	1	9	0

- (i) What is the design speed for redesigning existing MDR?  
(ii) What are upper and lower speed limits for mixed traffic?  
(iii) What are the different measures to increase the spot speed of vehicles moving on the road?  
(iv) Check whether the speed distribution is reasonably normal or not.

[12 Marks]

- (c) A straight bridge is set out between two points A and B, whose independent coordinates are given below:

Point	Northing (N)	Easting (E)
A	0	0
B	1200	100

It is required to set out the pillar at point C which is 400 m from point A. It is not possible to set the instrument either at point A or B. To set point C, another point P is selected at a horizontal distance of 600 m from A. Line AP has a bearing of 45°.

Calculate:

- (i) The independent coordinates of points C and P.  
(ii) The length and bearing of line PC.

[20 Marks]

