

ELECTRONICS AND TELECOMMUNICATIONS ENGINEERING

PAPER-II

Time Allowed: **Three Hours**

Maximum Marks: **300**

Question Paper Specific Instructions

Please reach each of the following instruction carefully before attempting questions:

There are **EIGHT** questions divided in **TWO** sections.

Candidate has to attempt **FIVE** questions in all

Questions **No.1** and **5** are **compulsory** and out of the remaining, any **THREE** are to be attempted choosing at least **ONE** question from each section.

The number of marks carried by a question/part is indicated against it.

Wherever any assumptions are made for answering a question, they must be clearly indicated.

Diagrams/figures, wherever required, shall be drawn in the space provided for answering the question itself.

Unless otherwise mentioned, symbols and rotations have their usual standard meanings.

Attempts of questions shall be counted in sequential order. Unless struck off, attempt of a question shall be counted even if attempted partly.

Any page or portion of the page left blank in the Question-cum-Answer Booklet must be clearly struck off.

Answers must be written in **ENGLISH** only.

SECTION-A

1. (a) A band limited random signal $X(t)$ has two-sided power spectral density $S_X(f)$ (PSD) given by

$$S_X(f) = \begin{cases} 10^{-6}(3000 - |f|) \text{ watts/Hz} & \text{of } |f| \leq 3 \text{ kHz} \\ 0, & \text{otherwise.} \end{cases}$$

Where f is frequency expressed in Hz.

This signal modulates a carrier $\cos 16000\pi t$ and resultant signal is passed through an ideal band pass filter of unit gain with central frequency of 8 kHz and bandwidth of 2 kHz. Draw two-sided power spectral density diagram for the given signal, modulated carrier and the output of the filter.

[10 Marks]

- (b) Convert the given block diagram to equivalent signal flow graph. Find the transfer function using Mason's Gain Formula.

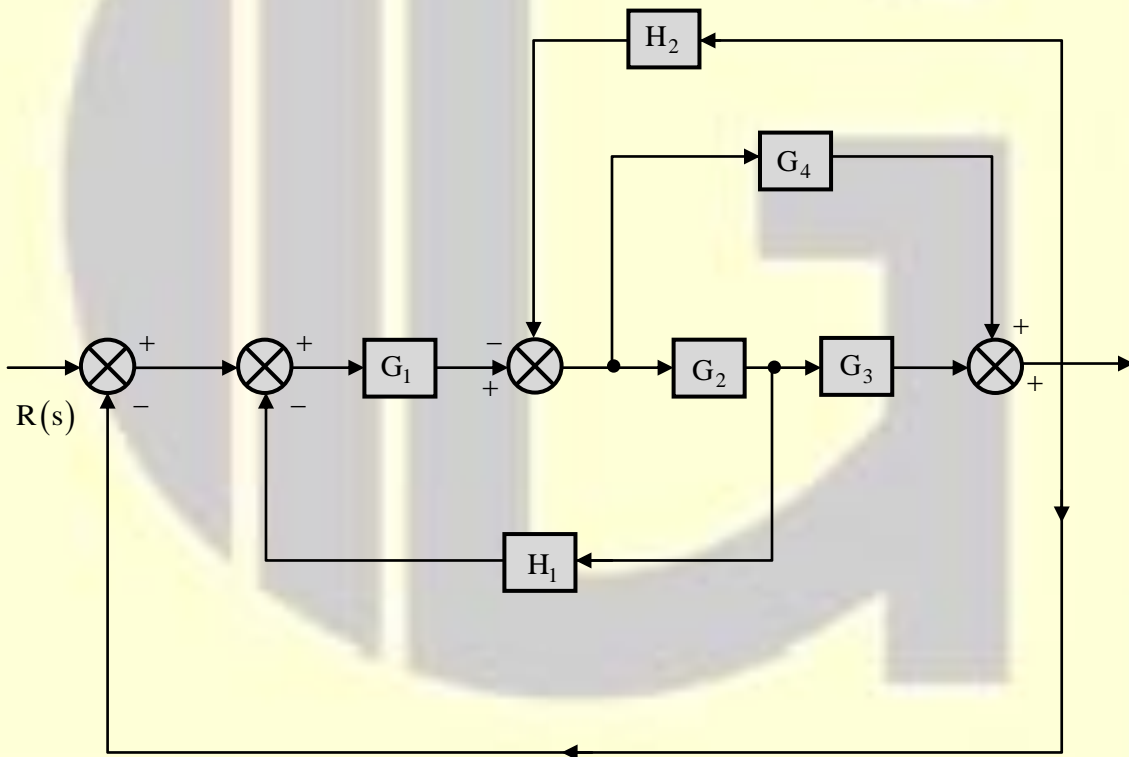

[10 Marks]

- (c) What do cores mean in a processor? Differentiate between Multi-core and Many-core architectures.

[10 Marks]

- (d) The electric field intensity of a linearly polarized uniform plane wave propagating in the +z direction in sea water is

$$\vec{E} = \hat{a}_x 100 \cos(10^7 \pi t) \text{ V/m at } z = 0.$$

The constitutive parameters of sea water are

$$\epsilon_r = 72, \mu_r = 1, \text{ and } \sigma = 4 \text{ (S/m.)}$$

Determine the intrinsic impedance, wavelength and skin depth. The value of ϵ_0 may be taken as 8.854×10^{-12} F/m, and $\mu_0 = 4\pi \times 10^{-7}$ H/m.

[10 Marks]

- (e) An electron beam exposure system operates at 20 kV accelerating voltage. Column length is 70 cm. Spot current is 500 nA, and numerical aperture of the final lens is 10^{-2} rad. The energy spread at the cathode is 0.2V. If the coefficients of spherical and chromatic aberration are 10 cm and 62.5 cm respectively, determine the resolution limit at the centre of the exposure field.

[10 Marks]

- (f) Between direct modulation and external modulation, which approach would you prefer as a dispersion management solution in case of optical fiber communication and why?

[10 Marks]

2. (a) A band limited analog signal of 5 kHz is sampled at twice the Nyquist rate. Each sample is quantized into 1024 equally likely levels that are statistically independent.

(i) Calculate information rate.

(ii) Can output of the source be transmitted without error over a Gaussian channel with a bandwidth of 50 kHz and signal to noise ratio of 30 dB?

(iii) What minimum bandwidth is needed to transmit the generated signal without error if a signal to noise ratio of 10 dB is needed to be maintained?

[5 + 5 Marks]

(b) Consider the block diagram of an LTI system shown below:

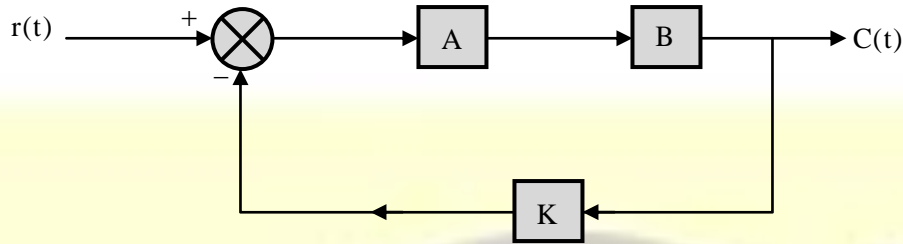

Block A has impulse response $h_A(t) = e^{-2t}u(t)$.

Block B has impulse response $h_B(t) = e^{-t}u(t)$.

Block K is an ideal amplifier of gain 'K'.

- (i) Calculate transfer function of the system when $K = 1$.
- (ii) Find impulse response of the system when $K = 0$.
- (iii) Find the value of K for which the system becomes unstable.

[5 + 5 + 10 Marks]

- (c) (i) Write a code or pseudocode (in any standard programming language) to swap two numbers without using third variable.
- (ii) Write a code or pseudocode (in any standard programming language) to swap two numbers using pointers.

[10 + 10 Marks]

3. (a) (i) The AM envelope observed on a CRO is shown below:

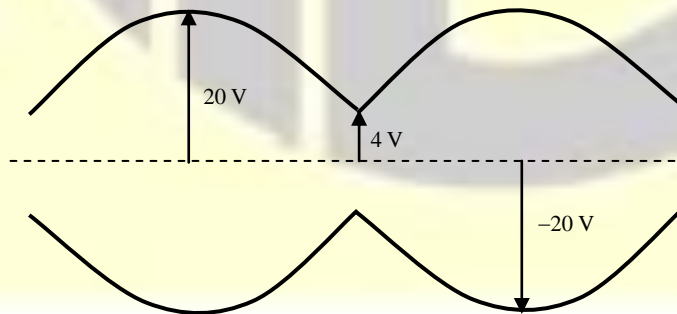

Determine the following parameters:

- I. Peak amplitude of upper and lower sideband
- II. Peak amplitude of the carrier

- III. Peak change in amplitude of modulated carrier
- IV. Modulation index and Modulation efficiency
- V. Power in sideband and total power

[2 × 5 = 10 Marks]

(ii) For a PCM system, determine:

- I. Minimum sampling rate
- II. Minimum number of bits used in PCM code
- III. Resolution
- IV. Maximum quantization error
- V. Coding efficiency

Assume:

Maximum analog input frequency = 4 kHz

Maximum decoded voltage at $R_x = \pm 2.55 \text{ V}$

Minimum dynamic range = 46 dB

[2 × 5 = 10 Marks]

(b) (i) A unity feedback system having forward transfer function

$$G(s) = \frac{K}{s(Ts + 1)}$$

is subjected to a unit-step input. Determine the values of K and T from the output response C(t) curve shown below:

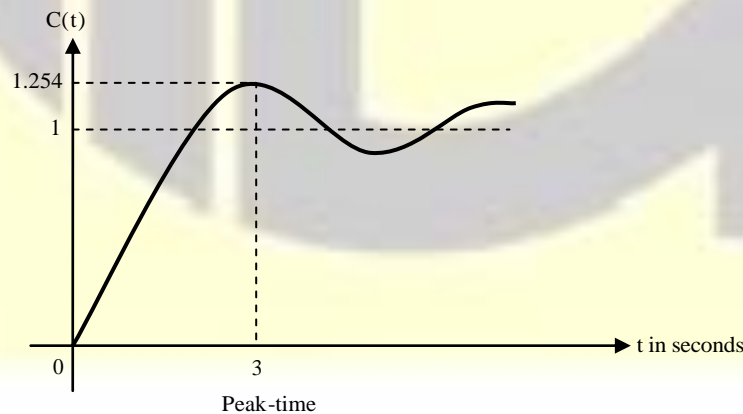

Also find the settling time of this system for 2% criterion.

- (ii) Design a PD controller so that the system having open loop function $G(s)H(s) = \frac{1}{s(s+1)}$ will have a phase margin of 40° at 2 rad/sec.

[10 + 10 Marks]

- (c) Consider a set of 5 processes for which arrival time, CPU time needed and the priority are given below:

| Process ↓ | Arrival time (ms) | CPU time needed (ms) | Priority |
|----------------|----------------------|-------------------------|-----------------|
| P ₁ | 0 | 10 | 5 th |
| P ₂ | 0 | 5 | 2 nd |
| P ₃ | 2 | 3 | 1 st |
| P ₄ | 5 | 20 | 4 th |
| P ₅ | 10 | 2 | 3 rd |

- (i) What will be the average waiting time if the CPU scheduling policy is SJF (without pre-emption)?
- (ii) What will be the average waiting time if the CPU scheduling policy is SJF (with pre-emption)?
- (iii) What will be the average waiting time if the CPU scheduling policy is priority scheduling (without pre-emption)?
- (iv) What will be the average waiting time if the CPU scheduling policy is priority scheduling (with pre-emption)?

[5 + 5 + 5 + 5 Marks]

4. (a) A discrete memoryless source generates either 0 or 1 at a rate of 160 kbps; 0 is generated three times more frequently than 1. A coherent binary PSK modulator is employed to transmit these bits over a noisy channel. The received bits are detected in a correlator fed with the basis function of unit energy (for this BPSK scheme) as the reference signal. The receiver makes a decision in favour of 1 if the correlator output is positive, else decides in favour of 0. If 0 and 1 are represented as

$$0 \rightarrow -(6\sqrt{2} \cos 640\pi \times 10^3 t) \text{ V}$$

$$1 \rightarrow +(6\sqrt{2} \cos 640\pi \times 10^3 t) \text{ V}$$

- (i) Determine transmitted signal energy per bit.
- (ii) Determine basic function of unit energy for this binary PSK scheme.

[12 + 8 Marks]

(b) For the system shown below,

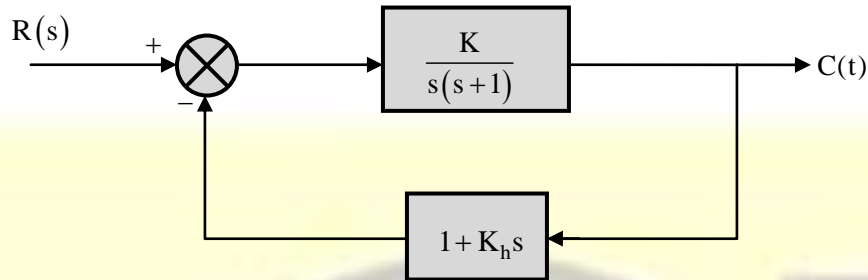

Draw the root-locus with $K_h = 0$ and K as variable. Obtain the value of K so that the system damping ratio is 0.158.

For the obtained value of K , draw the root-locus with K_h as variable. Find the value of K_h that improves the system damping ratio to 0.5.

[20 Marks]

- (c) (i) A processor array has 512 processors. Each processor is capable of adding a pair of integers in 1μ second. What is the performance (operations per second) of this processor array adding two integer vectors of length 1000, assuming each vector is allocated to the processors in a balanced fashion?
- (ii) A processor array has 512 processors. Each processor is capable of adding a pair of integers in 1μ second. What is the performance (operations per second) of this processor array adding two integer vectors of length 512, assuming each vector is allocated to the processors in a balanced fashion?

[10 Marks]

SECTION-B

5. (a) What are the causes of attenuation of light signal through the optical fiber? A certain optical fiber has an attenuation of 0.6 dB/km at 1300 nm and 0.3 dB/km at 1550 nm. Suppose the following two optical signals are launched simultaneously into the fiber: an optical power of 150 μ W at 1300 nm, and an optical power of 100 μ W at 1550 nm. What are the power levels in μ W of these signals at (i) 8 km, and (ii) 20 km?
- (b) Consider the unity-feedback system having forward transfer function

$$G(s) = \frac{K}{s(Js + F)}$$

The Bode plot of $G(s)$ is shown below as asymptotic approximation:

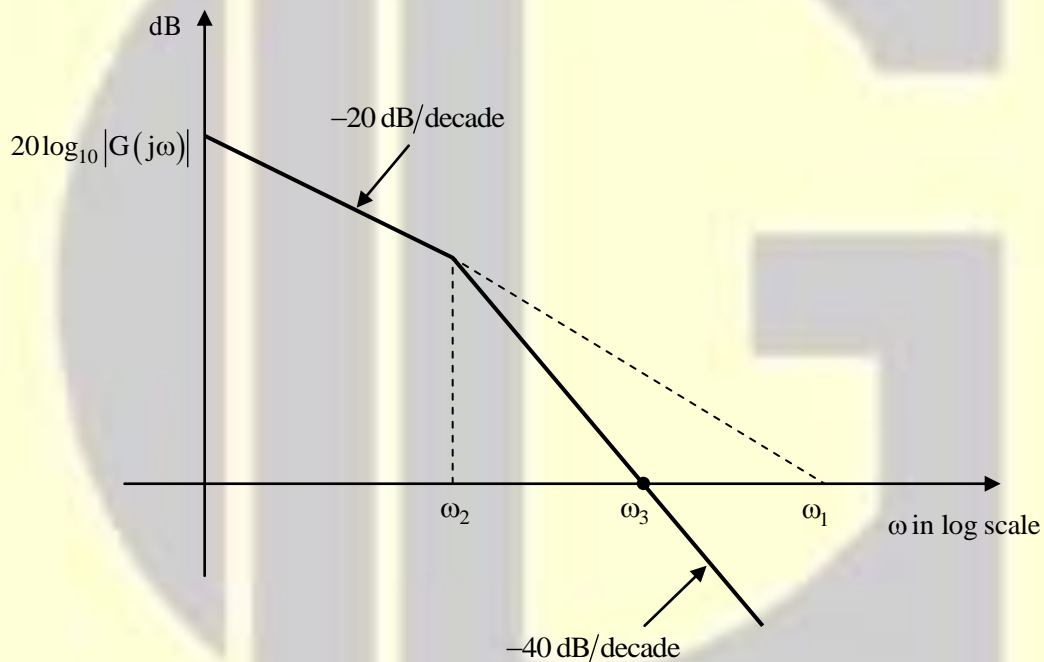

Express the relation between ω_1, ω_2 and ω_3 . Also find the static velocity error coefficient K_v of this system. You can assume $\omega_2 \ll \omega_3$.

[10 Marks]

- (c) The seek time of a disk is 30 ms. It rotates at the rate of 30 rotations per second. Each track has a capacity of 300 words. What will be the access time?

[10 Marks]

- (d) A wave at 10 GHz propagates in a rectangular waveguide with inner dimensions $a = 1.5$ cm and $b = 0.6$ cm. The conductivity of the waveguide walls is $\sigma = 1.57 \times 10^7$ S/m. The waveguide is filled with polyethylene with $\epsilon_r = 2.25$ and $\mu_r = 1$.

Calculate the guide wavelength and the wave impedance of the waveguide. Assume that dominant mode is propagating. Also determine the attenuation constant due to loss in the dielectric. The loss tangent of the polyethylene may be taken as 4×10^{-4} and the value of ϵ_0 is 8.854×10^{-12} F/m.

[10 Marks]

- (e) What will be the execution time for the instruction “STA addr” of 8085 with a clock frequency of 3 MHz? Number of T-states required by the instruction is 13.

[10 Marks]

- (f) Illustrate hop-to-hop (node-to-node) delivery by the data link layer.

[10 Marks]

6. (a) A 50Ω transmission line has phase velocity $v_p = 2.1 \times 10^8$ m/s. It is terminated by a load Z_L , which has a value of $Z_L = 75 + j25 \Omega$ at a frequency of $f = 29.6$ MHz.

Find the two closest positions to the load along the line where the real part of the line impedance is equal to the characteristic impedance of the line.

[20 Marks]

- (b) (i) An analog filter has a transfer function

$$H(s) = \frac{10}{s^2 + 7s + 10}$$

Design a digital filter equivalent to this using impulse invariant method for $T = 0.2$ s.

- (ii) Calculate the filter coefficients for a 5-tap FIR Bandpass filter with a lower cut-off frequency of 2 kHz and an upper cut-off frequency of 2.4 kHz at a sampling rate of 8 kHz.

[10 Marks]

- (c) (i) A digital fiber optical link working at 850 nm requires a maximum Bit Error Rate (BER) of 10^{-10} at a Data Rate (DR) of a 20 Mbps for a simple binary level signaling scheme. Take detector quantum efficiency as 1. [$h = 6.626 \times 10^{-34}$ J.s]

Determine the incident optical power that must fall on the photo detector to achieve the above-mentioned BER and DR.

- (ii) An optic fiber system uses a directly-modulated Distributed Feed-Back (DFB) laser as an optical source at the transmitter. If the operating bit rate = 2.5 Gbps, the dispersion parameter = 10 ps/(nm-km) and RMS spectral width of the pulse = 0.15 nm. Determine the maximum transmission distance.

[10 + 10 Marks]

7. (a) The scattering matrix of a two-port network is given by

$$[S] = \begin{bmatrix} 0.1 \angle 0 & 0.8 \angle 90^\circ \\ 0.8 \angle 90^\circ & 0.2 \angle 0 \end{bmatrix}$$

- (i) Determine whether the network is reciprocal or lossless.
(ii) If a short circuit is placed on port 2, what will be the resulting return loss at port 1?

[5 + 15 Marks]

- (b) Write an 8085 assembly language program to sort N numbers in descending order where value of N is available in memory location 9000 H. Also note that numbers are stored in consecutive memory locations starting from 9001 H.

[20 Marks]

- (c) (i) In the downlink of a GSM system, the carrier frequency is 950 MHz and according to GSM specification the receiver sensitivity is -102 dBm. The output power of the transmitter amplifier is 30W. The antenna gain of the transmitter antenna is 12 dB and the aggregate attenuation of connectors, combiners etc is 7db. The fading margin is 12 dB and breakpoint d_{break} is at a distance of 100 m. What distance can be covered? Take path loss exponent as 3.5.
- (ii) It is required to keep track of Mach 8 (1 Mach = 330 m/s) missiles coming towards a ship (positive Doppler shifts only) from a 500 km range with an L-band ($\lambda \approx 30$ cm) radar. The perfect waveform would have its range rate ambiguity beyond Mach 8 and its range ambiguity beyond 500 km. In this scenario, calculate PRF necessary to provide range rate ambiguity and range ambiguity. Also comment upon the result.

[10 + 10 Marks]

8. (a) An electric field strength of $10 \mu\text{V/m}$ is required at a point which is 200 km from a half-wave dipole antenna in the horizontal plane i.e., $\theta = \frac{\pi}{2}$. The antenna is operating in air at 50 MHz.

Calculate the current that must be fed to the antenna. Also find the average power radiated by the antenna. If a transmission line with characteristic impedance $Z_0 = 75 \Omega$ is connected to the antenna, determine the value of standing wave ratio.

[20 Marks]

- (b) (i) What do you mean by Electro-static Discharge (ESD) ? Why is ESD protection required? Suggest a protection method for ESD.
- (ii) Design a combinational circuit to generate the 9's complement of a BCD digit, using only two NOT gates, two 2-Input OR gates and one 2-Input X-OR gate.

[10 + 10 Marks]

- (c) (i) At a distance of 40,000 km from a point on the surface of Earth, a satellite radiates a power of 12 W from an antenna having a gain of 16 dB in the direction of the observer. Determine the flux density at the receiving point, and the power received by an antenna at this point with an effective area of 10 m^2 . Express both flux density and power received in decibel as well.
- (ii) Consider a satellite uplink has (C/N_o) of 82.2 dB and downlink has (C/N_o) of 79.8 dB. Assume bandwidth of the system as 1.2 MHz.
- I. Determine Numeric Value (NV) for each (C/N_o) value.
 - II. Calculate (C/N_o) for the system $(C/N_o)_s$.
 - III. Determine (C/N) at 1.2 MHz BW.

[10 + 10 Marks]

