

ELECTRICAL ENGINEERING PAPER-II

Time Allowed: **Three Hours**

Maximum Marks: **300**

Question Paper Specific Instructions

Please reach each of the following instruction carefully before attempting questions:

There are **EIGHT** questions divided in **TWO** sections.

Candidate has to attempt **FIVE** questions in all

Questions **No.1** and **5** are **compulsory** and out of the remaining, any **THREE** are to be attempted choosing at least **ONE** question from each section.

The number of marks carried by a question/part is indicated against it.

Wherever any assumptions are made for answering a question, they must be clearly indicated.

Diagrams/Figures, wherever required, shall be drawn in the space provided for answering the question itself.

Unless otherwise mentioned, symbols and notations carry their usual standard meanings.

Attempts of questions shall be counted in sequential order. Unless struck off, attempt of a question shall be counted even if attempted partly.

Any page or portion of the page left blank in the Question-cum-Answer Booklet must be clearly struck off.

Answers must be written in **ENGLISH** only.

SECTION-A

1. (a) An LTI system has the property that

$$a^n u(n) \rightarrow na^n u(n)$$

Considering the system as causal and stable, find the frequency response $H(\omega)$ of the system. Also, determine the difference equation that relates the input $x(n)$ and the output $y(n)$.

[12 Marks]

- (b) Consider a unity feedback system with open-loop transfer function given as

$$G(s) = \frac{(s-2)(s-4)}{(s+20)(s-3)(s^2+s+1)}$$

Sketch the root locus diagram for $G(s)$ and show that $G(s)$ cannot be stabilized by a stable controller.

[12 Marks]

- (c) The electromagnet shown in the figure below is used to lift a sheet of steel. The coil has 400 turns and a resistance of 5 ohms. The reluctance of the magnetic material is negligible. The magnetic core has a square cross-section of 5 cm by 5 cm. When the sheet of steel is fitted to the electromagnet, air gaps, each of length $g = 1$ mm, separate them. An average force of 550 newtons is required to lift the sheet of steel. Considering the fact that the same r.m.s. current is required to produce the same average torque when the supply is DC or 50 Hz AC, find the ratio of the two supply voltages (i.e., AC voltage r.m.s. value to DC voltage) to lift the sheet:

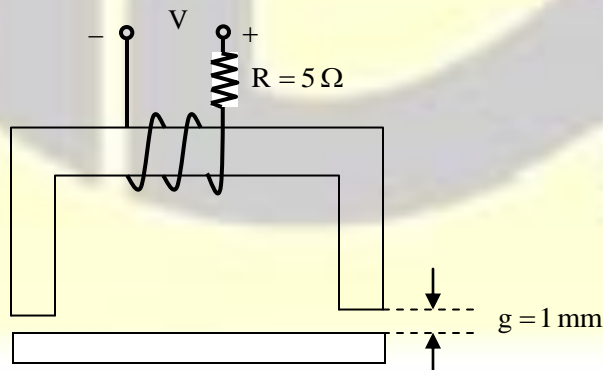

[12 Marks]

- (d) GO circuit of single-phase transmission line is composed of three solid conductors of radius 1.2 cm. The return circuit is composed of two solid conductors of radius 2 cm. The conductors layout is as shown in the figure below. Find the inductance per km of the complete line:

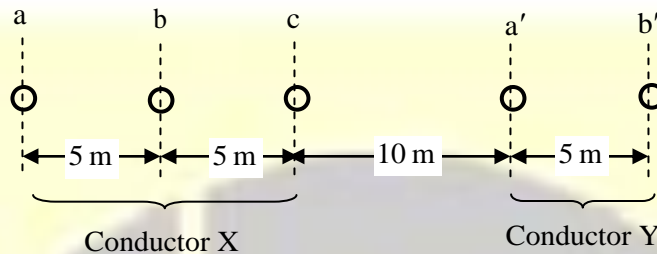

[12 Marks]

- (e) An ideal step-down (buck) DC-DC converter has an input voltage of 15 V. The required output voltage is 5 V and the peak-to-peak inductor current ripple is limited to 0.5 A. The output voltage ripple (peak-to-peak) is limited to 10 mV. The switching frequency of the converter is kept at 10 kHz. Find the value of the (i) inductor and (ii) capacitor.

[12 Marks]

2. (a) Design a digital sequence detector circuit to detect the sequence 0110 in a serial input signal, using D flip-flops. The sequence detector should produce an output 1 whenever it detects the sequence 0110 in the serial input signal, e.g.,

Serial Input X: 00110101101

Output Y: 00001000010

[20 Marks]

- (b) For the signals $x(t)$ and $y(t)$ given below, determine and sketch

$$\int_{-\infty}^t x(\tau) d\tau \text{ and } \int_{-\infty}^t y(\tau) d\tau :$$

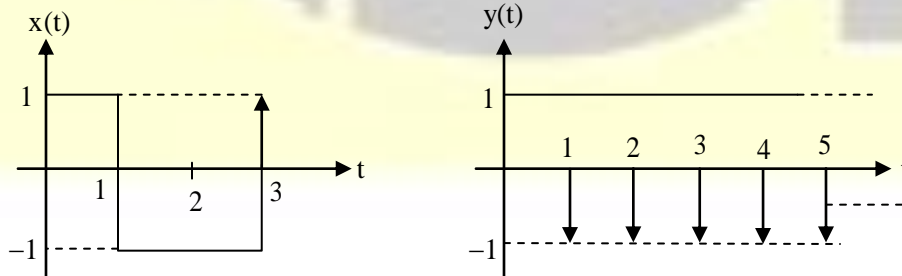

[12 Marks]

(c) The state-space representation of a linear system is given as

$$\dot{x} = \begin{bmatrix} 0 & 1 \\ -2 & -6 \end{bmatrix} x + \begin{bmatrix} 0 \\ 1 \end{bmatrix} u, y = [1 \quad 0] x$$

- (i) Using Ackermann's formula, design a state feedback control law such that the controlled system admits peak overshoot $M_p \leq 10\%$ and settling time $t_s \leq 1$ sec.
- (ii) Further, to achieve zero steady-state error for unit step inputs, an integral control block is inserted into the system as shown in the figure below:

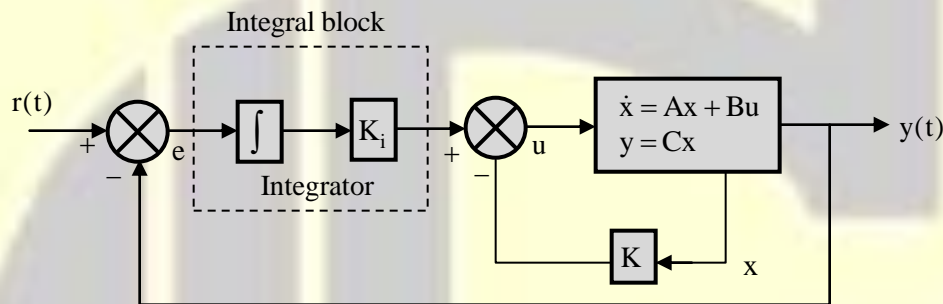

For this enhanced configuration, find the state feedback control gain K and integral block gain K_i such that the closed-loop system achieves same performance as in part (i), i.e., ($M_p \leq 10\%$ and $t_s \leq 1$ sec) with zero steady-state error.

[20 Marks]

3. (a) A servo system with tachometer feedback is shown below. Assuming K_b to be positive, determine the ranges of K and K_b for which the system is stable:

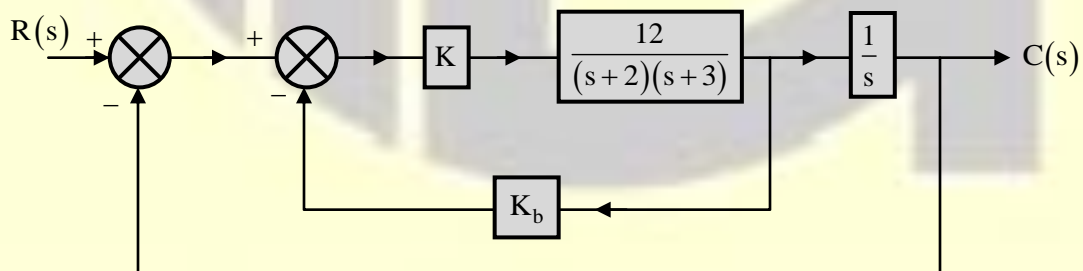

[20 Marks]

- (b) (i) A 240 V separately excited DC motor has an armature resistance of $r_a = 0.06 \Omega$. When it is connected to a 240 V supply, it draws 90 A from the supply and rotates at 1200 r.p.m.
1. Find the torque developed by the motor at this operating condition.
 2. For the same excitation and same supply voltage, if the torque developed is 280 N-m, find the speed and armature current.
- (ii) Explain briefly the various types of stepper motors. A three-stack stepper motor is used to produce a step size of 2° .
1. Determine the steps per revolution.
 2. Determine the number of rotor teeth.

[10 + 10 Marks]

- (c) (i) Explain, on the basis of their controllability, the different types of semiconductor switches used in power electronic circuits. Also, draw their output characteristics.
- (ii) Explain the 'variable voltage variable frequency' method of speed control of a three-phase induction motor. Draw the relevant characteristics showing the variation of torque and speed below the base speed and above it.

[10 + 10 Marks]

4. (a) Determine the time signals for the bilateral Laplace transforms given below.

Specify the properties used:

(i) $X(s) = \frac{1}{s^2} \cdot \frac{d}{ds} \left(\frac{e^{-3s}}{s} \right)$, ROC: $\text{Re}(s) > 0$

(ii) $X(s) = s \left(\frac{1}{s^2} - \frac{e^{-s}}{s^2} - \frac{e^{-2s}}{s} \right)$, ROC: $\text{Re}(s) > 0$

[20 Marks]

(b) A 50 MVA generating station is connected to a three-phase line having impedance $Z = 300 \angle 75^\circ \Omega$ and admittance $Y = 0.0010j \text{ S}$. The power at the generating station is 50 MVA at upf, at a voltage of 220 kV. There is a load of 25 MW at upf at the midpoint of the line. Find the-

- (i) voltage at the receiving end;
- (ii) complex power at the receiving end.

Use nominal-T model for the lines.

[20 Marks]

(c) The speed of a DC motor is controlled by a single-phase AC-DC full converter as shown in the figure below. The AC supply is 1- ϕ , 120 V, 50 Hz. The armature resistance $R_a = 1 \Omega$ and armature circuit inductance is $L_a = 25 \text{ mH}$. The motor voltage constant is 0.055 V/r.p.m. The field current of the motor is adjusted such that the armature voltage E_a is negative. The firing angle is $\alpha = 60^\circ$ and the speed of the DC machine is 200 r.p.m. Assume that the DC machine current is continuous and ripple-free:

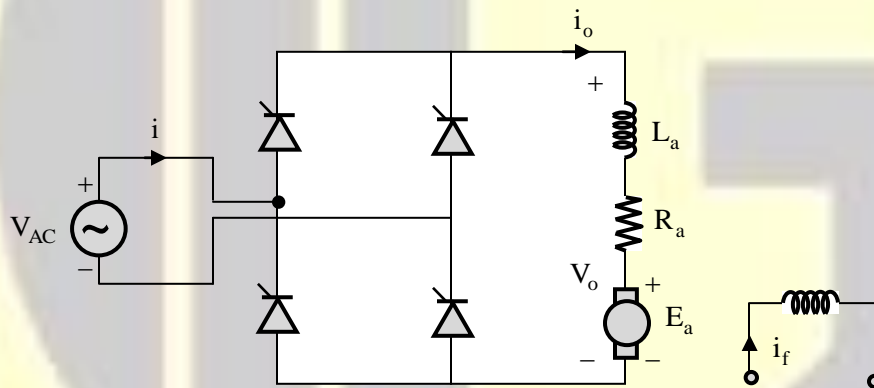

- (i) Determine the average value of the DC machine current.
- (ii) Determine whether the power is delivered or absorbed by the DC machine and also find this power.
- (iii) Determine whether the power is delivered or absorbed by the AC supply and also find this power.
- (iv) Explain where the power is going. Also, find the supply power factor.

[20 Marks]

SECTION-B

5. (a) A first-order system with unity feedback has forward path transfer function $G(s) = \frac{28}{s + \alpha}$. The system is connected in cascade with an integral controller whose transfer function is $G_s(s) = \frac{K_i}{s}$. If the required natural frequency $\omega_n = 12$ rad/sec and the permissible steady-state error for unit ramp input is 0.1, find the values of K_i and α .

[12 Marks]

- (b) Let $z = re^{j\omega}$ and $s = \sigma + j\Omega$. Use bilinear transformation to show that if $r < 1$, then $\sigma < 0$, and if $r > 1$, then $\sigma > 0$, and when $r = 1$, then $\sigma = 0$.

[12 Marks]

- (c) A single-phase, 10 kVA, 460/120 V, 50 Hz transformer has an efficiency of 96% when it delivers 9 kW at 0.9 power factor. This transformer is connected as an autotransformer to supply load to a 460 V circuit from a 580 V source.

- (i) Show the autotransformer connection with appropriate dot convention.
(ii) Determine the maximum kVA the autotransformer can supply to the 460 V circuit.
(iii) Determine the efficiency of the autotransformer for full load at 0.9 power factor.

[12 Marks]

- (d) A renewal energy-based power plant of 200 MW installed capacity has the following data:

Capital cost = ₹ 2,250 /kW

Interest + depreciation = 10%

Annual load factor = 0.7

Annual capacity factor = 0.6

Annual running cost = ₹ 40×10^6

Energy consumed by plant auxiliaries = 6%

Find the (i) reserve capacity and (ii) generation cost per unit.

[12 Marks]

- (e) A controlled half-wave rectifier has an AC source of 240 V r.m.s. at 50 Hz. The load is a $30\ \Omega$ resistor.
- (i) Determine the delay angle such that the average load current is 2.5 A.
 - (ii) Determine the power absorbed by the load.
 - (iii) Determine the power factor.

[12 Marks]

6. (a) (i) What is meant by primary protection and backup protection? Give the reasons of primary protection failure. Also, define the terms (1) pick-up value and (2) reset value.
- (ii) Explain the principle of Merz-Price system of protection used for power transformers.

[10 + 10 Marks]

- (b) In an 8085 microprocessor, an array of 34 bytes data is stored from memory location 8000H onwards. Certain six bytes data is available at memory location from 8100H to 8105H. Insert these six bytes into 34 bytes array starting from fourth location, i.e., 8003H onwards, such that the final array expands to 40 bytes. Write 8085 assembly language program with comments for this operation.

[20 Marks]

- (c) Determine the signal $x[n]$ and rational z-transform $X(z)$ for the following cases:

(i) $x[n]$ is right-sided, $X(z)$ has a single pole, $x[0] = 4$, $x[2] = \frac{1}{4}$

(ii) $X(z)$ has poles at $z = \frac{1}{4}$ and $z = -1$, ROC includes the point $z = \frac{1}{2}$, $x[1] = 1$, $x[-1] = 1$

[20 Marks]

7. (a) The open-loop transfer function of a system is given as

$$G(s) = \frac{e^{-5s}}{s(s+1)}$$

Design a lead compensator such that the overall compensated system admits phase margin $PM \geq 40^\circ$ and steady-state error due to ramp input $e_{ss} \leq 0.1$.

[20 Marks]

- (b) A three-phase, 5 kVA, 208 volts, four-pole, 60 Hz, star-connected synchronous machine has negligible stator winding resistance and a synchronous reactance of 8 ohms per phase at rated terminal voltage. The machine is operated as a generator in parallel with a three-phase, 208 volts, 60 Hz power supply.
- Find the excitation voltage and the power angle when the machine is delivering rated kVA at 0.8 PF lagging. Draw the phasor diagram for this condition.
 - If the field excitation is now increased by 20 percent (without changing the prime mover power), find the stator current, power factor and reactive kVA supplied by the machine.
 - With the field current a sin part (i), the prime mover power is slowly increased. What is the steady-state stability limit? What are the corresponding values of the stator (or armature) current and power factor at this maximum power transfer condition?

[20 Marks]

- (c) (i) The schematic diagram of a practical differentiator circuit using op-amp is as shown in the figure below:

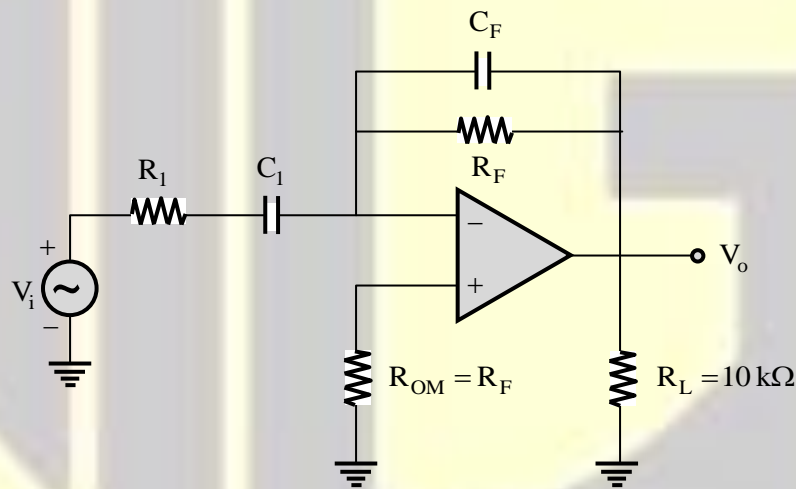

- Calculate the various component values, if the differentiator differentiates input signal from frequency 10 Hz to 2 kHz effectively.
- Also, sketch the output voltage (v_o) waveform, when the triangular wave as shown in the figure below is applied as input signal:

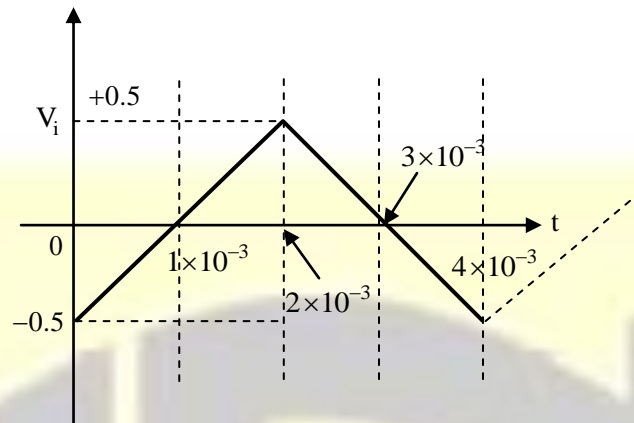

- (ii) For the op-amp circuit shown in the figure below, calculate the output voltage v_o and the current through $1\text{ k}\Omega$, when the input voltage $v_1 = 2\text{ V}$ and $R = 5\text{ k}\Omega$:

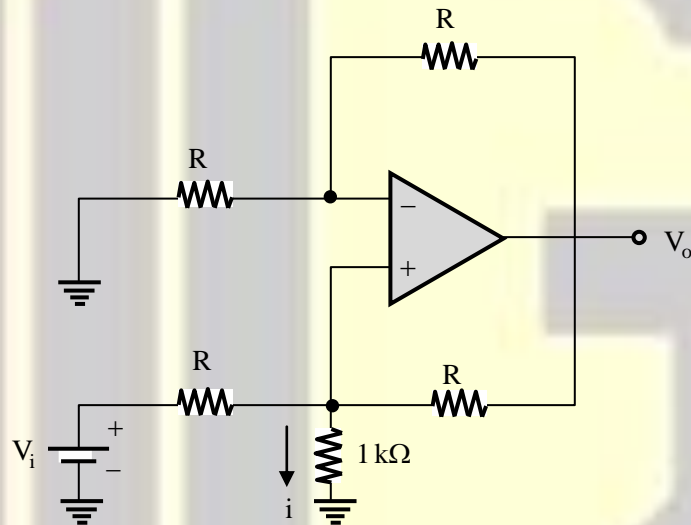

Also, compute the current i , if $1\text{ k}\Omega$ resistor is replaced by $2\text{ k}\Omega$ resistor.

[10 + 10 Marks]

8. (a) A three-phase induction machine is mechanically coupled to a DC shunt machine. The ratings and parameters of the two machines are as follows:

Induction machine:

Three-phase, 20kW, 400V, four-pole, 50Hz, 1425 r.p.m.

$$R_1 = 0.4 \Omega, X_1 = 0.55 \Omega, R'_2 = 0.35 \Omega, X'_2 = 1.1 \Omega, X_m = 38 \Omega$$

DC machine:

220V, 15 kW, 1500 r.p.m.

$$r_a = 0.4 \Omega$$

The induction machine is connected to a three-phase, 400 V, 50 Hz supply and the DC machine is connected to a 220 V DC supply. The rotational losses of each machine of the M-G set may be considered constant at 225 watts. The system rotates at 1425 r.p.m. in the direction of the rotating field of the induction machine.

- (i) Determine the mode of operation of the induction machine and also the current taken by it.
- (ii) Determine the real and reactive powers at the terminals of the induction machine and indicate their directions.
- (iii) Determine the copper loss in the rotor circuit of the induction machine.
- (iv) Determine the armature current (and its direction) of the DC machine.

(Given R_1, X_1 are the stator winding resistance and leakage reactance, R'_2, X'_2 are the corresponding rotor values referred to the stator side and X_m is the magnetizing reactance].

[20 Marks]

-
- (b) (i) Derive the expression for the fault current of the single line-to-ground fault, assuming that the fault is occurring in one of the phases of a three-phase, star-connected, unloaded generator with its neutral grounded through impedance Z_n .
- (ii) A three-phase, 20 MVA, 13.8 kV, star-connected, salient-pole generator has a direct-axis subtransient reactance of 0.25 pu. The negative and zero-sequence reactances are 0.35 pu and 0.10 pu respectively. The neutral of the generator is solidly grounded. Determine the subtransient current in the faulty phase and line-line voltage between non-faulty phases when a single line-to-ground fault occurs at the generator terminal with the generator operating unloaded at rated voltage. Neglect resistance.

[8 + 12 Marks]

- (c) (i) A single-phase, full-bridge inverter has input DC voltage $V_d = 250$ V. The output voltage fundamental frequency is 50 Hz. Find the r.m.s. value of fundamental output voltage and its first two prominent harmonics for square-wave mode of operation.
- (ii) Referring the inverter of part (i), if a motor-load of $R = 10 \Omega$, $L = 20$ mH is connected to the output of the inverter, find the value of fundamental and its two prominent current harmonics for square-wave mode of operation. Assume no filtering.

[10 + 10 Marks]

