

ELECTRICAL ENGINEERING PAPER-I

Time Allowed: **Three Hours**

Maximum Marks: **300**

Question Paper Specific Instructions

Please reach each of the following instruction carefully before attempting questions:

There are **EIGHT** questions divided in **TWO** sections.

Candidate has to attempt **FIVE** questions in all

Questions **No.1** and **5** are **compulsory** and out of the remaining, any **THREE** are to be attempted choosing at least **ONE** question from each section.

The number of marks carried by a question/part is indicated against it.

Wherever any assumptions are made for answering a question, they must be clearly indicated.

Diagrams/Figures, wherever required, shall be drawn in the space provided for answering the question itself.

Unless otherwise mentioned, symbols and notations carry their usual standard meanings.

Attempts of questions shall be counted in sequential order. Unless struck off, attempt of a question shall be counted even if attempted partly.

Any page or portion of the page left blank in the Question-cum-Answer Booklet must be clearly struck off.

Answers must be written in **ENGLISH** only.

SECTION-A

1. (a) Using double integral, find the volume in the positive octant of the ellipsoid.

$$\frac{x^2}{16} + \frac{y^2}{9} + \frac{z^2}{4} = 1.$$

[12 Marks]

- (b) The strength of one bond of Magnesium Oxide (MgO) is 10.54 eV. How much joules of energy for vapourization will be needed by 0.35 kg of Magnesium Oxide? (Take Avogadro number = 6.022×10^{23} atom/mol, charge of electron = 1.6×10^{-19} Coulombs, atomic mass of Mg = 24 u, atomic mass of Oxygen = 16 u).

[12 Marks]

- (c) What are Maxwell's equations in Point Form and Integral Form? How do these equations take form in free space?

[12 Marks]

- (d) For an abrupt silicon p-n junction with acceptor ion concentration $N_A = 4 \times 10^{16} \text{ cm}^{-3}$ and donor ion concentration $N_D = 10 \times 10^{15} \text{ cm}^{-3}$, if $T = 300 \text{ K}$, intrinsic carrier concentration $n_i = 1 \times 10^{10} \text{ cm}^{-3}$, calculate the maximum electric field in the depletion region when $V_a = -3.5$ volts. Assume relative dielectric constant of silicon $\epsilon_r = 11.8$, electron charge $q = 1.6 \times 10^{19} \text{ C}$, Boltzmann's constant $k = 1.38 \times 10^{-23} \text{ J/K}$, permittivity of free space $\epsilon_0 = 8.854 \times 10^{-12} \text{ F/m}$.

[12 Marks]

- (e) Write a 'C' program to identify whether the given input word is a 'palindrome'. The program should read the word from the terminal and display the message whether the input word is a palindrome or not. If the input word is 'END' it should exit the program.

[12 Marks]

2. (a) (i) Determine the eigen values and eigenvectors of $B = 2A^2 - \frac{1}{2}A + 3I$ where $A = \begin{bmatrix} 8 & -4 \\ 2 & 2 \end{bmatrix}$.
- (ii) Using the method of Lagrange's multipliers, find the largest product of the numbers x, y and z , when $x + y + z^2 = 25$.

[10 +10 Marks]

- (b) From atomic interpretations of spontaneous magnetization in ferromagnetic materials and the Curie-Weiss Law, determine Curie constant in terms of Bohr magneton (β) and N spins per m^3 in the material. Establish how spontaneous magnetization takes place below the Curie temperature.

[20 Marks]

- (c) (i) Give briefly the concept of precision in measurements. Explain with examples the roles of 'significant figures' on measurement of precision of a measuring tool.
- (ii) Using a standard cell of 1.016V, a simple potentiometer balances at 48.4 cm. Calculate: (I) the emf of a cell that balances at 72 cm, (II) the percentage error in a voltmeter, measuring a voltage which balances at 66 cm, when reading is 1.40 V.

[10 + 10 Marks]

3. (a) (i) Using the Cauchy-Riemann equations, show that $f(z) = f(r, \theta) = r^4 (\cos^4 \theta - 6\cos^2 \theta \sin^2 \theta + \sin^4 \theta) + 4ir^2 \sin \theta \cos \theta (\cos^2 \theta - \sin^2 \theta)$ is analytic in the entire z -plane and hence find its derivative in terms of z .
- (ii) The mutual inductance between two coils varies with the angle of displacement of the moving coil from its zero position as follows:

Angle (degree) (x)	0	15	30	60	90	105	120
Mutual Inductance (μH) (y)	-336	-275	-192	0	192	275	336

Determine the Pearson's Correlation Coefficient (r_{xy}) and the angle between the two regression lines formed by the above data.

[12 Marks]

- (b) (i) Two point charges of $Q_1 = 6 \text{ nC}$ and $Q_2 = 8 \text{ nC}$ are placed at $(2, 2)$ and $(6, 8)$ respectively. Show that the equation of the locus on which the electric field intensities due to Q_1 and Q_2 are equal represents a circle. Find its centre and radius.
- (ii) Determine the inductance per unit length of an air filled co-axial cable having a solid inner conductor of radius 'a' metres and a very thin outer conductor of inner radius 'b' metres. Assume that the current flows via the inner conductor and return in the outer conductor and is uniformly distributed over the cross-section of inner conductor.

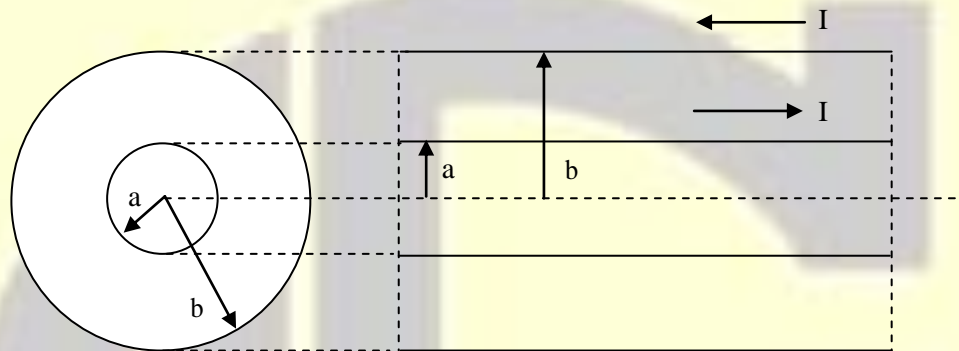

[10 + 10 Marks]

- (c) (i) The impedance of the basic ac bridge shown in the following figure is given as follows:
- $Z_1 = 100 \Omega \angle 80^\circ$ (inductive impedance)
- $Z_2 = 250 \Omega$ (pure resistance)
- $Z_3 = 400 \Omega \angle 30^\circ$ (inductive impedance)
- $Z_4 = \text{unknown}$

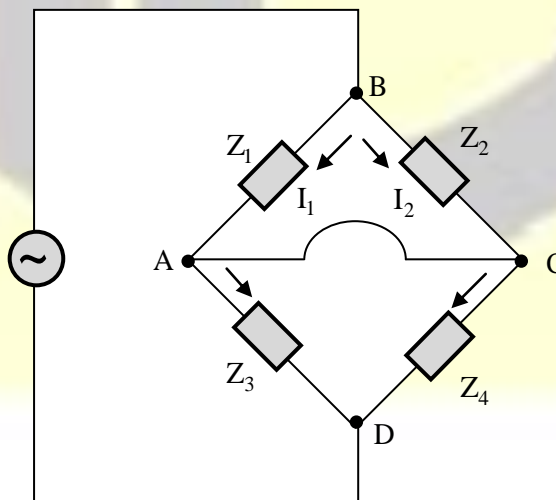

Determine the value of the constants of the unknown arm.

- (ii) Derive the equations for balance in the case of Maxwell's inductance capacitance bridge. Draw the phasor diagrams for balance conditions.

[10 + 10 Marks]

4. (a) (i) Determine the phasor voltage V_{AB} in the circuit given in the following figure.

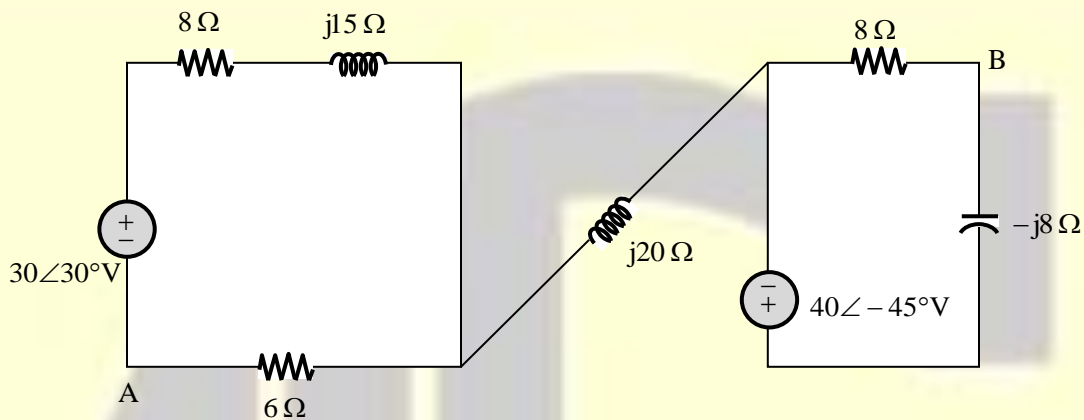

- (ii) A three-phase, four-wire, CBA system has an effective line voltage of 140 V and it has three impedances of $25\angle-30^\circ\Omega$ in a Y-connection, as shown in the figure. Determine the line currents and draw the voltage-current phasor diagram.

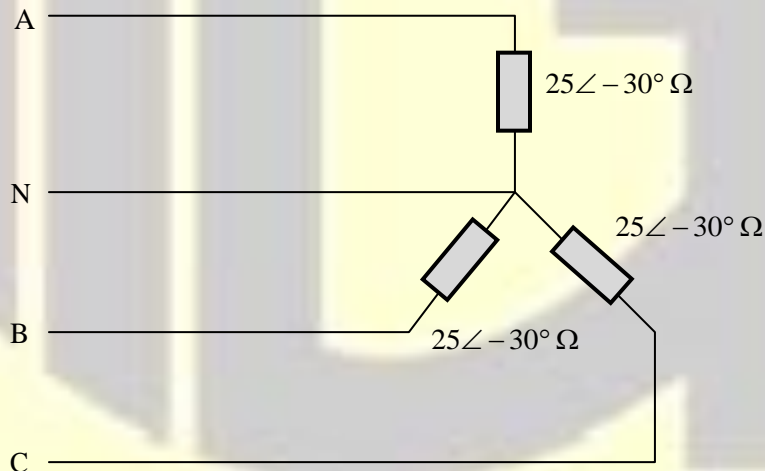

[10 + 10 Marks]

- (b) (i) A Hall voltage of 3.5×10^{-8} V in magnitude is generated for an aluminium specimen of 15 mm thickness with a current of 25A and a magnetic field of 0.6 Tesla, imposed in a direction perpendicular to the current. Calculate electron mobility for aluminium. (Take electrical conductivity for aluminium as $3.7 \times 10^7 \Omega/\text{m}$)
- (ii) Six micrograms of antimony are thoroughly mixed in molten form with 200 g of pure germanium and antimony atoms substitute for germanium atoms uniformly throughout the solid material. Determine the density of antimony atoms, the density of donated electrons and the conductivity, if electron mobility is $3500 \text{ cm}^2/\text{Vs}$, for the carriers.
- (Take charge of electron = 1.6×10^{-19} Coulombs, density of germanium = $5.46 \text{ gm}/\text{cm}^3$, atomic weight of antimony = 121.76 u, Avogadro number = 6.022×10^{23} atoms/mol)

[12 Marks]

- (c) (i) The dimensions of the coil of a moving coil voltmeter are 3 cm and 2.5 cm and the coil has 150 turns. The scale has 100 divisions. The air gap flux is $0.15 \text{ Wb}/\text{m}^2$. Determine the series resistance when the meter is to be used for 0 – 100 V. The spring constant is 2.5×10^{-6} Nm per division and the resistance of the coil is 1Ω .
- (ii) In 10 A dynamometer type ammeter, the rate of the change of mutual inductance with deflection is constant and is equal to $0.005 \mu\text{H}$ per degree. It has a full scale deflection of 90° . Find the deflection when the current to be measured is 5A.

[10 + 10 Marks]

SECTION-B

5. (a) In the following figure, a current filament of 6.5A in the \bar{a}_y direction is parallel to the y-axis at $x = 2\text{m}$, $z = -2\text{m}$. Determine \vec{H} at the origin.

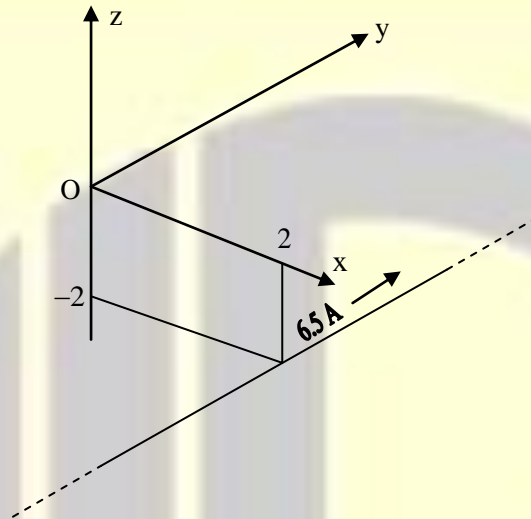

[12 Marks]

- (b) Derive an expression for the dielectric constant (ϵ_r) in elemental dielectrics, in terms of the atomic quantities.

[12 Marks]

- (c) (i) P is a 16 bit signed integer. The 2's complement representation of P is $(F87B)_{16}$. Find the 2's complement representation of the product $(8P)$.

- (ii) In the circuit shown below if $C = 0$, find the expression for Y by minimization.

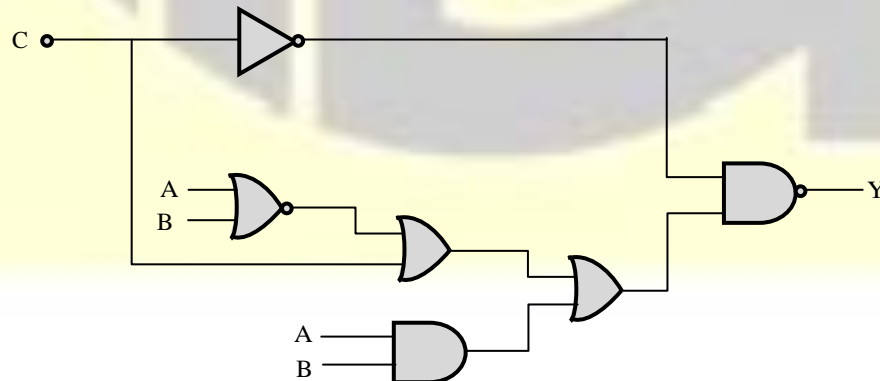

[6 + 6 Marks]

- (d) Explain with necessary diagrams how a dual slope integrating type ADC operates for conversion of analog input voltage digital form.

[12 Marks]

- (e) Identify the type of feedback in the BJT circuit shown below. Draw the general feedback model showing the basic amplifier and feedback network. Find the input impedance and output impedance with feedback of the circuit shown. Its parameters are $R_C = 5\text{ k}\Omega$, $R_F = 50\text{ k}\Omega$, $R_S = 15\text{ k}\Omega$, $h_{ie} = 1200\ \Omega$, $h_{fe} = 60$ and $h_{re} = h_{oe} = 0$.

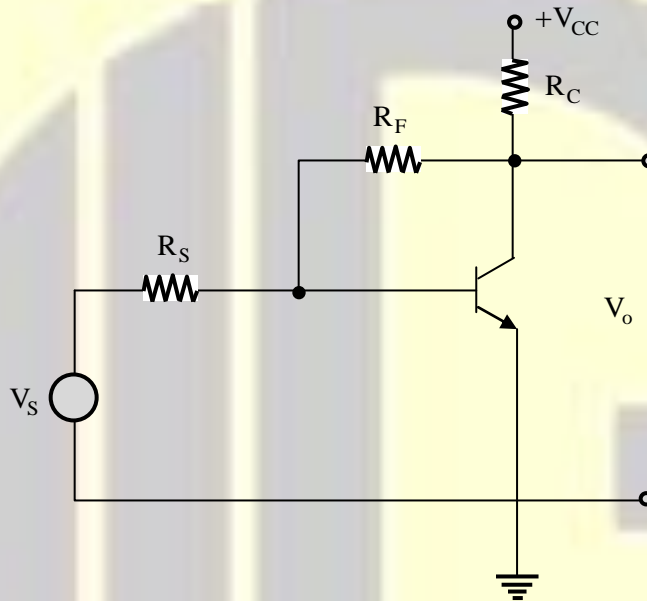

[12 Marks]

6. (a) (i) Draw the circuit diagram of Hartley oscillator using FET. If $L_1 = 15 \text{ mH}$ and $C = 50 \text{ pF}$, Calculate the L_2 for a frequency of oscillation of 168 kHz . The mutual inductance between L_1 and L_2 is $5 \mu\text{H}$. Find the required value of μ of FET to be used for this circuit.
- (ii) For the FET amplifier below, determine V_{DQ} and I_{DQ} . Assume that FET is operating in its saturation region.

Given,

$$V_{DD} = 12 \text{ V}$$

$$K_n = 0.24 \text{ mA/V}^2$$

$$V_{TN} = 3 \text{ V}$$

$$R_1 = 10 \text{ M}$$

$$R_E = 2 \text{ K}$$

$$\lambda = 0$$

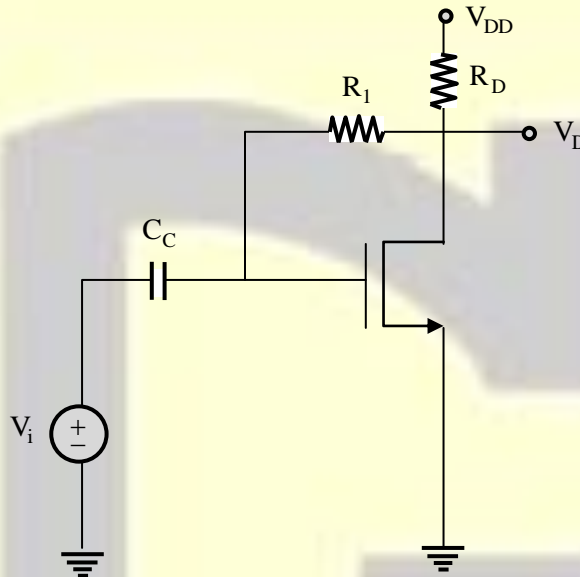

[10 + 10 Marks]

- (b) Given $\frac{dy}{dx} = \frac{y-x}{y+x}$, $y(0) = 1$, compute $y(0.02)$ in steps of 0.02 using

- (i) Modified Euler's method and
(ii) Fourth order Runge-Kutta method correct four decimal places.

[20 Marks]

- (c) (i) A digital computer has a memory unit with 32 bits per word. The instruction set consists of 270 different operations. All instructions have an operation code and an address part allowed for only one address. Each instruction is stored in one word of memory. Find the number of bits needed for op-code, for address part of instruction and the maximum allowable size of memory.
- (ii) The distance between two stations is 'L' kilometers and all the frames are 'K' bits long, and the propagation delay per kilometer is 't' seconds and the channel capacity between them is 'R' bits/second. Find the minimum number of bits 'b' for the sequence number field in a frame for maximum utilization, if the sliding window protocol is used. Assume processing delay to be negligible. Derive the equation for 'b'.

[10 + 10 Marks]

7. (a) (i) The reverse saturation currents I_{S_1} and I_{S_2} of transistors Q_1 and Q_2 respectively, which are shown in the circuit below are:

$$I_{S_1} = 2I_{S_2} = 5 \times 10^{-16} \text{ A. If } I_1 = 1.2 \text{ mA}$$

find

(I) the value

(II) the value of R_C which places transistors at the edge of active region.

Assume volt equivalent of temperature $V_T = 26 \times 10^{-3} \text{ V}$.

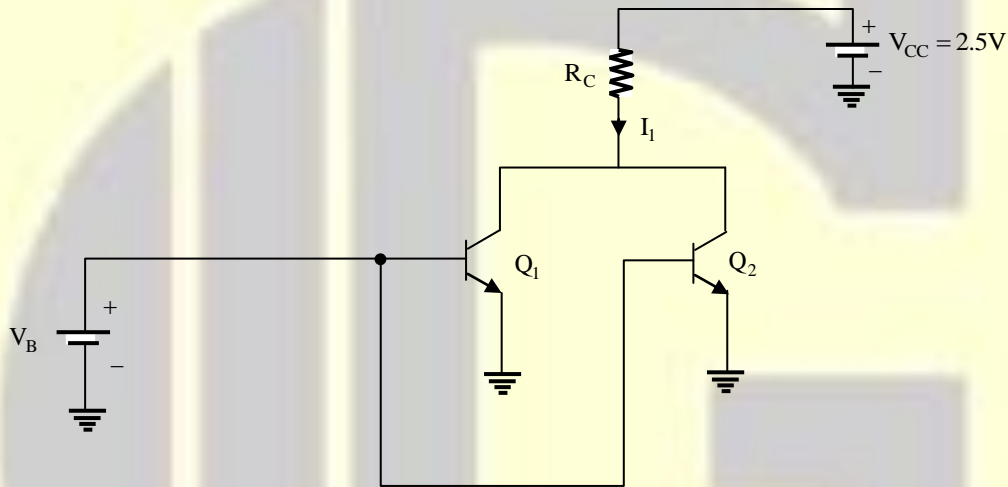

- (ii) An n-channel JFET amplifier circuit is shown in the figure below. The JFET parameters are the drain to source saturation current $I_{DSS} = 12 \text{ mA}$, pinch off voltage $V_p = -4 \text{ V}$, the channel length modulation coefficient $\lambda = 0.008 \text{ V}^{-1}$. Find the small signal transconductance g_m and voltage gain A_v .

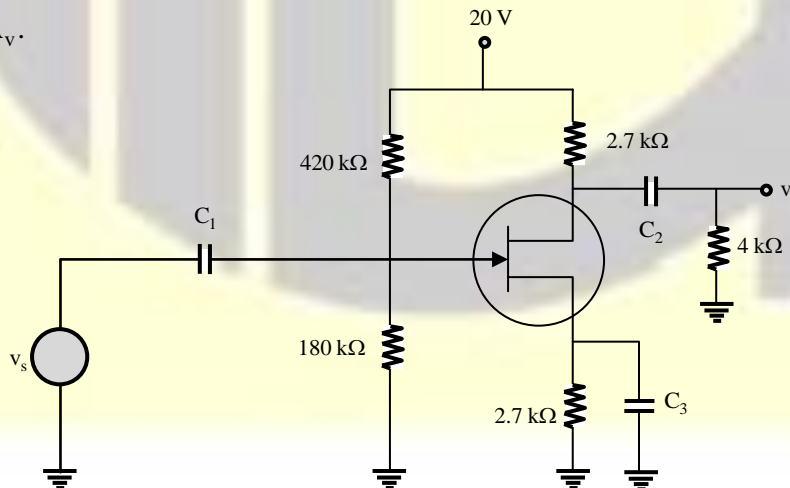

[10 + 10 Marks]

- (b) (i) A 1000/100 V potential transformer has the following parameters:

Primary resistance = 97.5Ω

Primary reactance = 65.4Ω

Second resistance = 0.86Ω

Total equivalent reactance = 110Ω

Magnetizing current at 0.4 p.f. = 0.02 A

Find (I) the phase angle error at no load, and (II) load in VA at unity power factor at which the phase angle error will be zero.

- (ii) A Phantom loading arrangement is used to test a 220 V, 5 A dc energy meter at its marked ratings. The resistance of the pressure coil circuit is 8800Ω and that of current coil is 0.1Ω . Calculate the power consumed when testing the meter with:

(I) Direct loading arrangements.

(II) Phantom loading with current coil circuit excited by a 6V battery.

[12 + 8 Marks]

- (c) (i) If $\vec{F} = (2x^3 - 3z)\mathbf{i} - 2xy\mathbf{j} - 4x\mathbf{k}$, then evaluate $\iiint_V \nabla \times \vec{F} dV$, where V is bounded by the planes $x = 0$, $y = 0$, $z = 0$ and $2x + 2y + z = 4$ where $\nabla = \mathbf{i} \frac{\partial}{\partial x} + \mathbf{j} \frac{\partial}{\partial y} + \mathbf{k} \frac{\partial}{\partial z}$.

- (ii) Find the Fourier series for $f(x) = x^2, 0 < x < 4$. Also draw the graph of its periodic extension.

[12 Marks]

8. (a) (i) A strain gauge of cross-sectional area 3.6 cm^2 has been bonded to a beam 0.1 m long. The gauge factor of the strain gauge is 2.2 and the unstrained resistance of the strain gauge is 220Ω . Young's modulus of steel (beam) is 207 GN/m^2 . Due to application of a load, the resistance of the gauge changes by 0.015Ω .

Calculate the change in length of the steel beam and the amount of force applied to the beam.

- (ii) Specify the reasons of using 'Sample and Hold' circuits in multi-channel data acquisition system. Draw and explain briefly the working of a S/H circuit.

[10 + 10 Marks]

- (b) (i) A series RC circuit has $R = 10 \text{ k}\Omega$ and $C = 15 \mu\text{F}$ and the circuit has two voltage sources in series, given by $v_1 = 20u(-t) \text{ V}$ and $v_2 = 20u(t-t') \text{ V}$. Determine the complete expression for the voltage across the capacitor and plot it as a function of time, assuming t' as a positivity quantity.
- (ii) Find the T equivalent of the linear network given in the following figure.

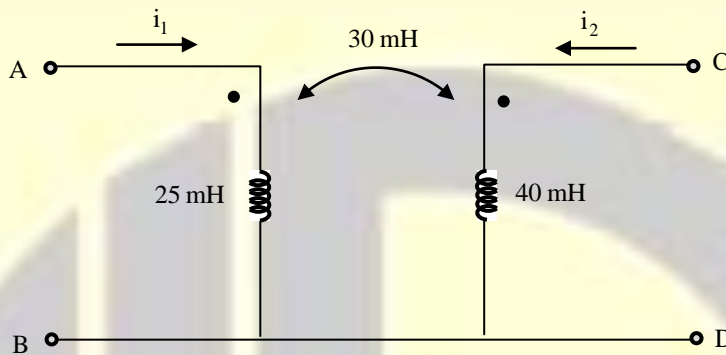

Establish the equivalence between the network and its T equivalent.

[12 + 8 Marks]

- (c) The current source circuit shown in the figure below has $I_{\text{REF}} = 0.7 \text{ mA}$ and $I_o = 25 \mu\text{A}$ at $V_{C_2} = 1$ volt. The transistor parameters are $\beta = 150$, $V_{\text{BE}_1(\text{ON})} = 0.7$ volts and Early voltage $V_A = 100 \text{ V}$. Determine $R_1, R_E, V_{\text{BE}_2(\text{ON})}$ and change in I_o when V_{C_2} changes from 1V to 4V. Assume that the two transistors are identical and are maintained at same temperature. Derive the equations used.

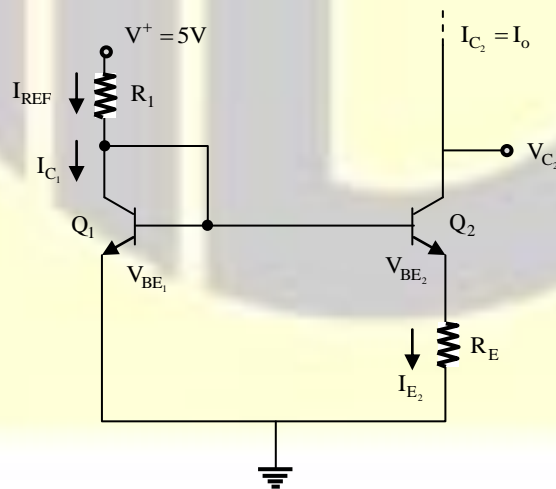

[20 Marks]